

Mitigation of Climate Change Impacts on Runway Friction

Kuujuaq Airport

by

Karolina Konarski

A thesis

presented to the University of Waterloo

in fulfillment of the

thesis requirement for the degree of

Master of Applied Science

in

Civil Engineering

Waterloo, Ontario, Canada, 2014

© Karolina Konarski 2014

AUTHOR'S DECLARATION

I hereby declare that I am the sole author of this thesis. This is a true copy of the thesis, including any required final revisions, as accepted by my examiners.

I understand that my thesis may be made electronically available to the public.

Abstract

In response to global climate change, Transport Canada has initiated a Climate Change Adaptation Study in order to provide an opportunity to improve knowledge of the impacts of climate change on transportation infrastructure in Northern Canada.

In particular, this research aims to identify ways to mitigate the impacts of climate change on pavement surface friction characteristics at a project specific location: Runway 07-25 of Kuujjuaq Airport in Nunavik, Québec. This site was chosen because it is a complex site with highly variable soil conditions. Runway 07-25 is one of the busier runways in Nunavik and its traffic includes jet airplanes. The runway is also exposed to extensive winter maintenance activities. In addition, Runway 07-25 is considered a short runway and has a crossfall instead of crown for surface drainage. Increasing ambient temperatures have already led to a deeper active layer over permafrost, which affects overall runway performance. Climate change is especially evident in the winter months with large temperature fluctuations resulting in increased freeze thaw cycles. The site is, therefore, a good location to study solutions to climate change impacts, which are expected to affect other Canadian airports in the future.

Kuujjuaq Runway 07-25 is of paramount importance to the community of Kuujjuaq, other communities in Nunavik, and communities north of Nunavik. It serves as a regional hub between the south, Nunavik's communities and Iqaluit to the north, and provides an essential link for emergency evacuations, personal and business travel, as well as the transportation of basic food items.

Globally, amongst the groups, the most affected by the impacts of climate change are the Inuit communities in Nunavik. Scientists and residents of these communities are witnessing growing evidence of the impacts of accelerated warming in this region, which is expected to continue into the future.

In this research, runway texture and friction are assessed on Runway 07-25, as increased winter maintenance activities resulting from climate change are thought to be reducing surface friction. Existing friction and texture measurement data from previous years, current laboratory testing results on samples of the existing asphalt concrete mix as well as current surface texture and friction measurement data from the runway have been analysed to study trends and characterize the runway in terms of its frictional resistance. Friction improving technologies/products are discussed for maintenance and future rehabilitation options.

Acknowledgements

I would like to acknowledge the following individuals for their assistance during this research project.

- Andre Leclerc, Transport Canada
- Fiona Genevieve Beaudoin, Transport Canada
- Michael H. MacKay, LVM
- Luc Chartrand, LVM

I would also like to thank my supervisor, Dr. Susan Tighe, from the Department of Civil and Environmental Engineering at the University of Waterloo for her wonderful guidance, help, encouragement and motivation over the course of this project as well as throughout my entire Masters studies.

Last, but certainly not least, I would like to thank my family for their love, encouragement and support throughout my Masters program and in furthering my education.

Table of Contents

AUTHOR’S DECLARATION.....	ii
Abstract.....	iii
Acknowledgements.....	iv
Table of Contents.....	v
List of Tables.....	viii
List of Figures.....	ix
Chapter 1 Introduction.....	1
1.1 Introduction.....	1
1.2 Research Objectives.....	2
1.3 Thesis Methodology.....	2
Chapter 2 Literature Review.....	5
2.1 Community.....	5
2.2 Importance of the Kuujjuaq Runway.....	6
2.3 Climate Change Impacts in Nunavik.....	7
2.4 Effects of Climate Change on Runways.....	8
2.4.1 Effects of Climate Change on Frictional Resistance of Kuujjuaq Runway.....	8
2.4.2 Effects of Climate Change on Surface Roughness.....	9
2.5 Surface Friction of Runway Pavements.....	10
2.5.1 Background on Friction, Microtexture and Macrottexture of Runways.....	10
2.5.2 Case Study – Runway Overrun in St.John’s, Newfoundland.....	17
2.6 Methods of Assessing Friction and Texture on Pavement Surfaces.....	19
2.6.1 British Pendulum Test.....	19
2.6.2 Sand Patch Test.....	20
2.6.3 Outflow Meter Test.....	21
2.6.4 GripTester.....	22
2.7 Aircraft Movements at Kuujjuaq Airport.....	23
2.7 Current Methods of Snow Removal and Ice Control on Kuujjuaq Runway.....	24
2.8 Chapter Summary.....	25

Chapter 3 Analysis and Discussion of Previous Field Testing Data	28
3.1 Previous Friction Measurement Data on Kuujjuaq Runway	28
3.2 December 2012 Site Inspection	34
3.3 Chapter Summary	36
Chapter 4 Analysis and Discussion of Laboratory Testing Results.....	39
4.1 Existing Asphalt Concrete Specifications for Kuujjuaq Airport	39
4.2 Asphalt Cement Content and Gradation	39
4.2.1 Asphalt Content	39
4.2.2 Gradation.....	40
4.3 Marshall Properties	40
4.3.1 Preparation of Specimens Using Marshall Apparatus	40
4.3.2 Marshall Stability and Flow.....	41
4.4 Bulk Relative Density	43
4.5 Maximum Relative Density	44
4.6 Air Voids.....	45
4.7 In-Situ Pavement Compaction	46
4.8 Asphalt Binder PGAC Classification.....	46
4.9 British Pendulum Test.....	49
4.10 Chapter Summary	50
Chapter 5 2013 Field Testing Data Analysis and Discussion.....	52
5.1 Findings.....	53
5.1.1 Outflow Meter Testing.....	53
5.1.2 Sand Patch Testing.....	57
5.1.3 British Pendulum Testing	59
5.1.4 Friction Testing.....	61
5.1.4.1 Predicting Future Performance	69
5.1.5 Coring Investigation.....	73
5.2 Chapter Summary	74
Chapter 6 Friction Improvement Technologies for Kuujjuaq Runway 07-25	77
6.1 Runway Grooving.....	77

6.1.1 Advantages of Grooving	79
6.1.2 Disadvantages of Grooving.....	80
6.2 Shotblasting.....	80
6.2.1 Advantages of Shotblasting	80
6.2.2 Disadvantages of Shotblasting.....	81
6.3 Slurry Seal.....	81
6.3.1 Advantages of Slurry Seal	82
6.3.2 Disadvantages of Slurry Seal.....	82
6.4 Overlay with Hot Mix Asphalt (ESG-10 Gyratory)	82
6.4.1 Advantages of HMA Overlay	83
6.4.2 Disadvantages of HMA Overlay.....	84
6.5 Chapter Summary	84
Chapter 7 Conclusions and Recommendations.....	86
7.1 Conclusions of Field Testing Results Completed in Previous Years	86
7.2 Conclusions of 2013 Field Testing	86
7.2.1 Macrotexture Testing	87
7.2.2 Microtexture Testing.....	88
7.2.3 Friction Testing.....	88
7.3 Maintenance/Rehabilitation Recommendations	89
References.....	93
Appendix A Supplemental Graphs Showing 2013 and 2011 Friction Testing Data	97
Appendix B Runway Texture and Friction Contour Maps with 2013 Data	118
Appendix C FWD Contour Map with 2010 Data	125

List of Tables

Table 2.1 Factors affecting pavement microtexture and macrotexture (NCHRP, 2009)..	14
Table 2.2 Factors influencing pavement friction (NCHRP, 2009).	15
Table 2.3 Type and amount of aircraft movements on Runway 07-25	24
Table 3.1 Transport Canada Friction Number guidelines (Tradewind Scientific Ltd., 2011)	31
Table 3.2 2012 Texture survey results	35
Table 4.1 Comparison of test results in Year 2000 vs. 2013 – % asphalt cement	40
Table 4.2 Comparison of gradation test results/requirements in Year 2000 vs. 2013	40
Table 4.3 Comparison of marshall properties in Year 2000 vs. 2013	41
Table 4.4 British Pendulum test results of Kuujjuaq asphalt samples	49
Table 4.5 British Pendulum test results of typical asphalt concrete mixes	49
Table 5.1 Summary of mean texture depths	59
Table 5.2 Summary of British Pendulum test results	60
Table 5.3 Summary of GripTester results from 2013 and 2011	63
Table 5.4 2013 100 m Minimum GripTester results below 60	65
Table 5.5 Comparison of GripTester results from 2004 to 2013	66
Table 6.1 Typical physical properties of ESG-10 mix (Québec Ministre des Transports, n.d.)	83
Table 6.2 ESG-10 gradation requirements (Québec Ministre des Transports, n.d.)	83

List of Figures

Figure 1.1 Map of Québec (Canada Maps, n.d.).....	2
Figure 1.2 Overview of research methodology.....	4
Figure 2.1 Nunavik and its Inuit communities (Allard & Lemay, 2012)	5
Figure 2.2 Comparison of population by village in Nunavik and variation in percent between 2006 and 2011 (Allard & Lemay, 2012).	6
Figure 2.3 Aerial view of Kuujuaq Airport (Centre for Northern Studies, 2012).	9
Figure 2.4 Illustration of pavement microtexture and macrotexture (Pinto, 2012).	11
Figure 2.5 Close up of microtexture and macrotexture (AAPTP, 2007)	12
Figure 2.6 Coefficient of friction vs. tire slip (NCHRP, 2009).	16
Figure 2.7 Key mechanisms of pavement-tire friction (NCHRP, 2009).	16
Figure 2.8 Schematic of British Pendulum Tester (FloorSlip UK, 2013)	20
Figure 2.9 Sand Patch test (Field site visit, 2012)	21
Figure 2.10 Typical Outflow Meter apparatus (National Driller, 2001).....	22
Figure 2.11 Typical GripTester (<i>Skid Resistance (Surface Friction) Tester</i> , n.d.).	23
Figure 2.12 Snow removal blade types (International Civil Aviation Organization [ICAO], 2002).....	25
Figure 3.1 Average Grip Number measurement results under controlled self watering and varying rain conditions	29
Figure 3.2 Minimum 100 m Grip Number measurement results under controlled self watering and varying rain conditions.....	30
Figure 3.3 2011 Outflow Meter results (mean texture depth)	32
Figure 3.4 Mean texture depth, 3 m left of runway centreline	33
Figure 3.5 Mean texture depth, 3 m right of runway centreline	33
Figure 3.6 Photographs from December 2012 site inspection.....	36
Figure 4.1 Marshall compaction hammer (LVM Toronto laboratory, 2013)	42
Figure 4.2 Marshall Stability machine (LVM Toronto laboratory, 2013).....	43
Figure 4.3 Scale for weighing specimens (LVM Toronto laboratory, 2013)	44
Figure 4.4 Maximum Relative Densometer tester (LVM Toronto laboratory, 2013)	45
Figure 4.5 Penetration test equipment (LVM Toronto laboratory, 2013).....	47
Figure 4.6 Bending Beam Rheometer (LVM Toronto laboratory, 2013).....	48

Figure 4.7 Dynamic Shear Rheometer (LVM Toronto laboratory, 2013).....	48
Figure 4.8 British Pendulum Tester (LVM Toronto laboratory, 2013).....	50
Figure 5.1 2013 Outflow Meter test results	53
Figure 5.2 2011 Outflow Meter test results	55
Figure 5.3 2011 vs. 2013 Outflow Meter test results at centreline.....	56
Figure 5.4 Outflow Meter test results at 3 m left of centreline at various years.....	56
Figure 5.5 Outflow Meter test results at 3 m right of centreline at various years	57
Figure 5.6 Sand Patch test results	58
Figure 5.7 British Pendulum test results	60
Figure 5.8 2013 GripTester operations (Field Testing, 2013)	62
Figure 5.9 Friction testing results at standard test conditions.....	67
Figure 5.10 Friction testing results at various offsets from centreline and 0.25 mm water depth.....	68
Figure 5.11 Friction testing results at 3 m left and right offsets from centreline and at various water depths/rain intensity	68
Figure 5.12 Friction testing results at standard test conditions from 2011 and 2013	69
Figure 5.13 Friction testing results from multiple years.....	72
Figure 5.14 Regression models.....	72
Figure 5.15 Core 1, 3 m left of centreline at station 5+250 m.....	73
Figure 5.16 Core 2, 10 m left of centreline at station 5+375 m.....	74
Figure 6.1 Effect of grooves on macrotexture (ICAO, 2012).....	77

Chapter 1

Introduction

This chapter includes a brief introduction and research objectives. In addition, the methodology and organization of the thesis are presented.

1.1 Introduction

In response to global climate change, Transport Canada (TC) has initiated a Climate Change Adaptation Study in order to provide an opportunity to improve knowledge of the impacts of climate change on transportation infrastructure in Northern Canada.

In particular, this research aims to identify ways to mitigate the impacts of climate change on runway pavement surface friction characteristics at a project specific location: Runway 07-25 of Kuujjuaq Airport in Nunavik, Québec. Kuujjuaq is located above the 58th parallel, at the southern limit of discontinuous permafrost distribution as shown in Figure 1.1. This site was selected because of some particular characteristics of the runway such as high traffic volumes and various airplane types combined with an unfavorable geometry (short runway length and crossfall for surface drainage) and large temperature variations (freeze-thaw cycles) during winter, which have not existed in the past. The presence of runway crossfall and longitudinal rutting result in problematic surface drainage, ponding of water on the runway surface, and ice formation in the winter months. Global climate change is especially evident in the winter months by the large temperature fluctuations and resulting increases in freeze thaw cycles. Also, increasing ambient temperatures have already led to a deeper active layer over permafrost, which affects overall runway performance. The site is, therefore, a good location to study solutions to climate change impacts, which are expected to affect other Canadian airports in the future.



Figure 1.1 Map of Québec (Canada Maps, n.d.)

1.2 Research Objectives

The primary objectives of this research project include:

- Examination of the surface properties of the runway (texture and friction) by analysis of data obtained in previous years;
- Presentation of laboratory and field testing results and analysis including a comparison of past and current runway condition; and
- Provide recommendations for the improvement of runway surface friction properties.

1.3 Thesis Methodology

The research methodology is presented in Figure 1.2. The components of the thesis include outline of scope and objectives, literature review, previous and new data collection including current laboratory and field testing, data analysis, and conclusions and recommendations.

The first part of the literature review covers a geographical review of Nunavik and its communities including Kuujuaq, the history and importance of Kuujuaq airport, and discusses climate change impacts in Nunavik to date including the effects which climate change has had on Kuujuaq runway and other roads/airports in Nunavik. The next part of the literature review provides a detailed background on the different components of

surface friction and texture of runway pavements, and a case study about a runway overrun in Newfoundland. In addition, methods/techniques for improving surface friction on runway pavements are explored in the thesis, including advantages and disadvantages of each. Finally, methods for assessing friction and texture on pavement surfaces are described and aircraft movements and current snow/ice removal and control techniques employed at Kuujjuaq airport are identified.

The next part of the thesis covers a data review and analysis of previous friction/texture results from Kuujjuaq runway. Various friction/texture surveys have been completed at Kuujjuaq airport from 2004 to 2011. This part of the thesis reviews these data in detail, identifies trends and determines the state of the runway in terms of friction and texture up to 2011. A program of laboratory testing was completed in 2013 on samples of hot mix asphalt from Kuujjuaq airport to classify the mix and complete microtexture testing. These samples were obtained from a stockpile at Kuujjuaq airport and are representative of the surface course hot mix asphalt used on the runway.

The research involved developing a data collection program which included field testing of the runway for 2013. The primary purpose of this testing was to analyze current data to gain an understanding of the current condition of the runway in terms of friction and texture, and in order to compare and evaluate performance trends. Based on the analysis of the field testing results, conclusions and recommendations for improving surface friction are presented.

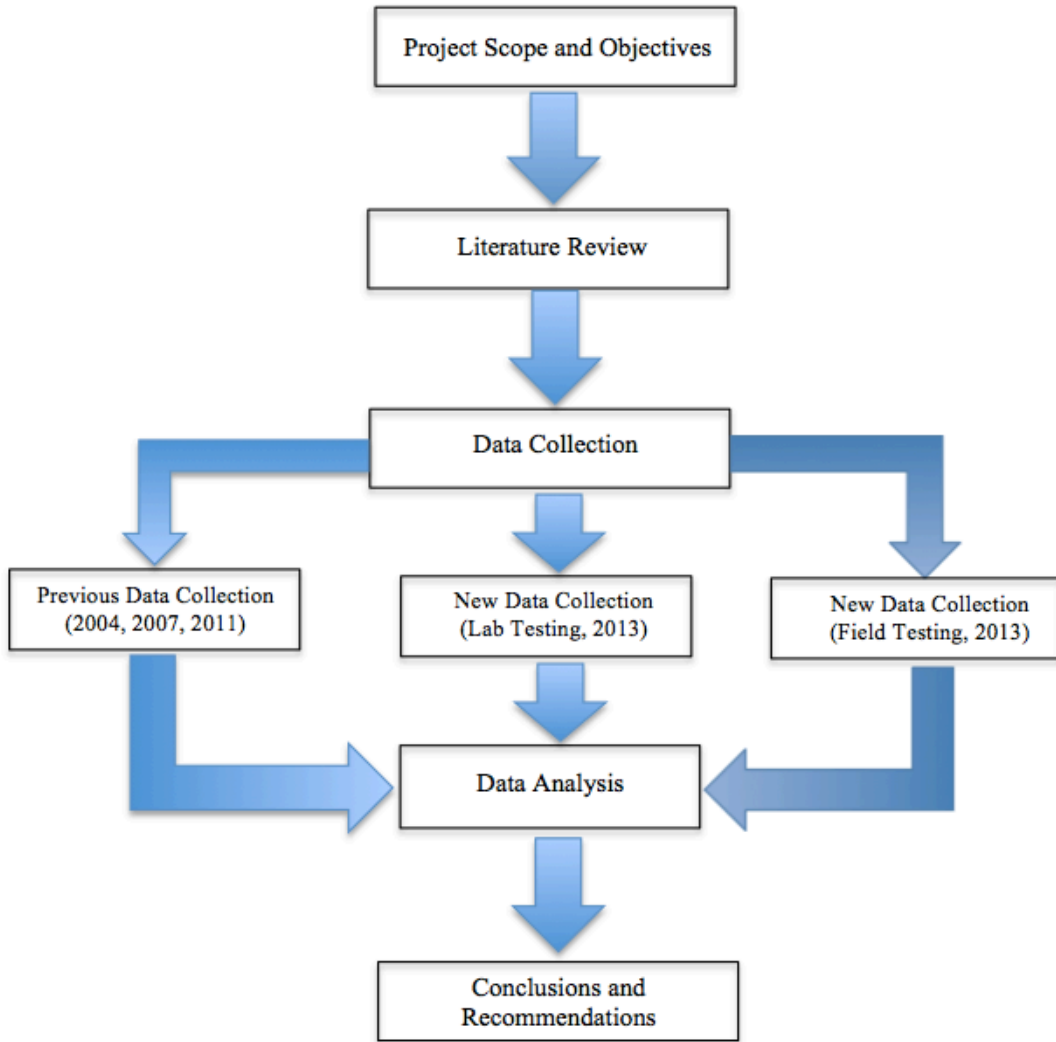

Figure 1.2 Overview of research methodology

Chapter 2

Literature Review

The purpose of this chapter is to provide some background information on Kuujuaq and the surrounding communities, including how the climate has been changing and affecting infrastructure to date, information about Kuujuaq airport including the type and amount of aircraft movements and current methods of snow removal and ice control on the runway. In addition, background information is provided regarding the general effects of climate change on runway surface friction, microtexture, macrotexture and methods for assessing surface texture and friction on pavement surfaces.

2.1 Community

Nunavik and Nunatsiavut are located between 55°N and 63°N on the eastern edge of North America, as outlined on Figure 2.1.



Figure 2.1 Nunavik and its Inuit communities (Allard & Lemay, 2012)

The region is bounded by bodies of water on three sides: Hudson Bay to the west, Hudson Strait and Ungava Bay to the north, and the Labrador Sea to the east. An extensive north-south mountain chain (Torngat Mountains with elevations of about 1500 m) in northern Nunatsiavut acts as a barrier to the Atlantic air masses moving into Nunavik. Snow and ice cover in Nunavik are present on average from November to May, and the region is affected by winter storms that follow tracks up the Hudson Bay to Foxe Basin, and up the Labrador Coast to Baffin Bay (Allard & Lemay, 2012).

Kuujuaq is the regional capital of Nunavik and is located about 50 km upstream from the mouth of the Koksoak River estuary in Ungava Bay. Originally, the Inuit community and the Hudson's Bay Company installations existed on the east side of the river (which is now a historic site called Old Fort Chimo). The community moved to its current site at

the location of the former United States Army airport (now Kuujjuaq Airport) after World War II (Allard & Lemay, 2012).

Kuujjuaq airport was constructed in 1942 as a U.S. Air Force base (Crystal 1). The base was occupied by the American army between 1941 and 1945, which sped up the development of the community. At the end of World War II, the United States turned the base over to the Canadian Government.

Figure 2.2 shows a comparison of the populations between the Unuit Communities in Nunavik, based on a Statistics Canada Census from 2001, 2006 and 2011, and the percent variation (increase in population growth) between the 2006 and 2011 censuses. Kuujjuaq is shown to have the greatest population, at approximately 2400 in 2011. The community of Kuujjuaq hosts a regional hospital, the Kativik Regional Government, the Makivik Corporation head office and the Nunavik Research Centre (Allard & Lemay, 2012).

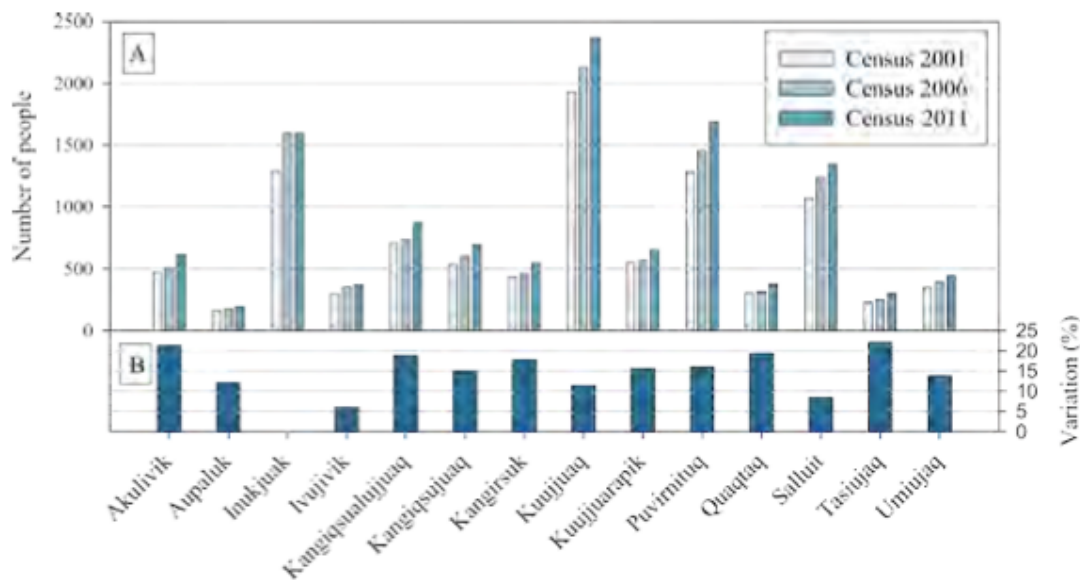

Figure 2.2 Comparison of population by village in Nunavik and variation in percent between 2006 and 2011 (Allard & Lemay, 2012).

2.2 Importance of the Kuujjuaq Runway

Northern communities are dispersed over a widespread area, and transportation of both people and goods is carried out by sea and air. The heaviest goods are transported to the north by ship but air transportation provides flexibility, speed and year-round services that are crucial to northern communities. Air transportation is the principal means of travel between northern communities and provides the essential link with the south (Allard & Lemay, 2012).

Kuujuaq airport is an important gateway and regional hub between the south, Nunavik's communities and Iqaluit to the north, providing an essential link for emergency evacuations, personal and business travel, as well as the transportation of basic food items and serving a population of about 4000 (Kativik Regional Government, 2013). Thus, Kuujuaq Runway 07-25 is of paramount importance to the community of Kuujuaq and other communities in Nunavik.

2.3 Climate Change Impacts in Nunavik

Globally, amongst the groups, the most affected by the impacts of climate change are the Inuit communities in Nunavik and Nunatsiavut. Scientists and residents of these communities are witnessing growing evidence of the impacts of accelerated warming in the region, which is expected to continue into the future. The increasing air temperatures, combined with changes in the natural and the socio-economic environment, is creating multiple effects on the ecosystem and society with significant impacts on human health and overall quality of life (Allard & Lemay, 2012).

“The vulnerability of the region to climate change has been highlighted in recent years due to an abrupt and unprecedented warming that began around 1993. This warming has contributed to wide-reaching and rapid environmental changes. For example, snow and ice cover duration are currently decreasing at a rate of about 1.0 day/year, ground temperatures have warmed by over 2°C with significant increases in active layer depth over permafrost. Glaciers in the Torngat Mountains lost approximately 20% of their total area between 2005 and 2007. Inuit knowledge indicates that these recent changes are outside the range of previous community experience. Together with more unpredictable weather, these changes are having wide-ranging impacts on human health, safety, municipal infrastructure and access to territory and resources” (Allard & Lemay, 2012).

Since regular satellite observations began in the early 1970s, snow cover duration has decreased about 3-4 weeks over northern Nunavik and Nunatsiavut. In the 1990s (when observations ceased), ice on the Koksoak River in Kuujuaq was observed to be melting an average of 3 weeks earlier than it did in the 1950s. Warming and resulting thawing of permafrost terrain has resulted in a significant increase in the number of thermokarst lakes and active layer detachments, and increases in tree and shrub abundance have been documented at various locations. The unusual nature of these changes is clearly visible in the paleo-temperature records and is confirmed by traditional knowledge (Allard & Lemay, 2012).

Traditional knowledge is a useful source of information regarding the unusual events and trends resulting from climate change (particularly duration of ice and snow cover) that have significant impacts on transportation. While this type of information is not

quantitative, it provides information on locally observed environmental change. For instance, the Elders of Quaqtq, Umiujaq and Kuujjuaq have reported that since the 1980s, ice forms later in the year and melts earlier, there is greater precipitation in the form of rain and less snow, and wind patterns have changed in the Hudson Bay and Hudson Strait areas (Allard & Lemay, 2012).

2.4 Effects of Climate Change on Runways

2.4.1 Effects of Climate Change on Frictional Resistance of Kuujjuaq Runway

As a result of climate change, fluctuations in ambient temperatures drastically vary from year to year and also during a given year. Precipitation levels are increasing, and the amount of time which ice cover is present on the Koksoak River running parallel to Runway 07-25 has diminished, resulting in increased fog generation in the immediate area of the airport. Figure 2.3 shows the proximity of the Koksoak River to the Runway 07-25. When fog condenses and freezes on the runway surface, black ice forms. This, combined with unusual temperature variations during a given winter, results in an augmented requirement for runway maintenance activities such as de-icing (chemical means) and brooming (mechanical means), which are necessary to remove the ice from the runway surface. In addition, rutting on the runway surface, increasing crosswinds, runway crossfall, water ponding and ice formation result in an augmented requirement for brooming. The increased winter maintenance activities are thought to result in diminishing pavement surface friction properties (decreasing microtexture and increasing macrotexture). In addition, increasing annual freeze thaw cycles are leading to additional problems with the runway pavement performance.



Figure 2.3 Aerial view of Kuujjuaq Airport (Centre for Northern Studies, 2012).

2.4.2 Effects of Climate Change on Surface Roughness

Most airports and access roads in Nunavik were built at a time when climate was considered stable, mainly during the 1980s and early 1990s (or earlier). As air temperatures increased during the 1990s and 2000s, permafrost thawing and resulting ground instability and thaw settlement began affecting gravel runways and access roads. In some, severe cases, depressions in runways occurred from thaw settlement resulting in safety issues. Maintenance rates were increased, which resulted in significantly greater operating costs (Allard & Lemay, 2012).

The future climate may include changes in the frequency and severity of extreme events such as heat waves and heavy rainfalls. Documented evidence exists of increased precipitation over the Arctic region as well as increases in the frequency of extreme precipitation events due to human influences (Allard & Lemay, 2012).

At Kuujjuaq Airport, climate change effects have been observed in recent years. For example, operations nearly ceased (for jet airplanes) in December 2010 when Runway 07-25 was experiencing excessive bumps due to differential frost heave. The bumps (which are small, localized, upward displacements of the pavement surface) were occurring as a result of non-uniformity in the frozen ground. Some areas of granular base/subbase/subgrade below the asphalt of the runway were completely frozen and others only partially frozen.

2.5 Surface Friction of Runway Pavements

2.5.1 Background on Friction, Microtexture and Macrottexture of Runways

Runway pavements should be designed to provide good bearing strength, good riding quality and good surface friction characteristics. In addition, necessary means should be taken to ensure that these properties are preserved during the entire life span of the pavement. Providing good bearing strength is the structural design goal for pavement, providing good riding quality is the geometric design goal, and providing good surface friction characteristics is the goal for achieving good texture and surface drainage. Additionally, goals in good pavement design are to ensure the longevity of the pavement and design a surface that is easy to maintain; as this will lead to economic savings and optimized use of the runway (Pinto, 2012).

Runway pavement surface friction can be achieved through correct pavement mix designs and placement during construction. High friction can be achieved by properly engineering the aggregate macrottexture and microtexture in the pavement (Pinto, 2012).

Many surface features contribute to the overall pavement surface texture with different combinations of texture depth (amplitude) and feature length. The features include aggregate texture and gradation, pavement finishing techniques and pavement wear. Following are three categories of pavement surface characteristics that have been established based on their amplitude and wavelength.

- Microtexture has longitudinal wavelengths of 0.001 mm to 0.5 mm and vertical amplitudes less than 0.2 mm. It is the surface profile of individual pieces of aggregate, and is a function of aggregate mineralogy. Microtexture provides both wet and dry frictional resistance on the pavement. Microtexture has a strong influence on friction at lower speeds.
- Macrottexture has longitudinal wavelengths of 0.5 mm to 50 mm and vertical amplitudes of 0.2 mm to 30 mm. It is the distribution and profile of the surface aggregate relative to the overall pavement surface profile. Macrottexture provides surface canals that provide a means for water to escape from between the tire and the pavement surface during wet weather conditions.
- Megatexture has longitudinal wavelengths of 50 mm to 0.5 m which are a result of surface deviations. Good megatexture is important for ensuring good pavement/tire contact by limiting wheel deviation and areas that can accumulate water (Airfield Asphalt Pavement Technology Program [AAPT], 2007).

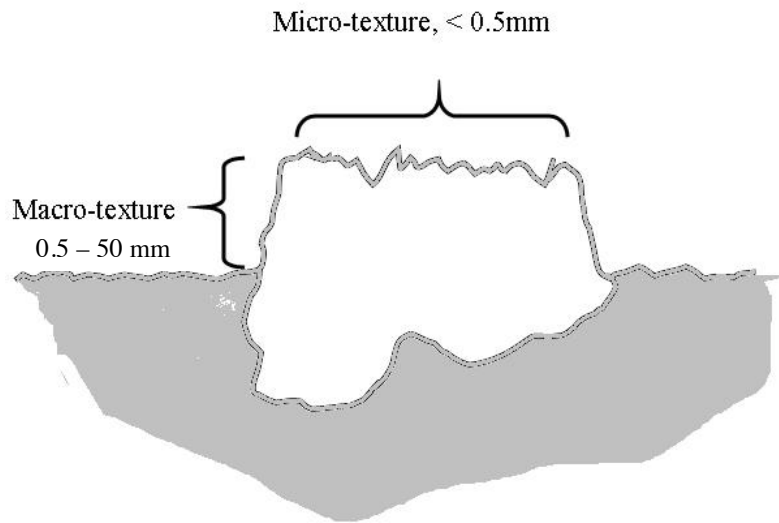

Figure 2.4 Illustration of pavement microtexture and macrotexture (Pinto, 2012).

Figure 2.4 shows the difference between pavement surface macrotexture and microtexture. Although microtexture is generally not visibly discernible, the rough microtexture of a pavement can be felt when the aggregate surface is examined by hand. The friction provided by the microtexture is important for aircrafts travelling at low speeds. The pavement microtexture is a result of the aggregate selection in asphalt pavements; choosing coarsely graded aggregates in the mix design will lead to better microtexture. Using aggregate with high silica content also helps prevent polishing of the aggregate and maintains the coarse microtexture (Pinto, 2012).

The macrotexture of a pavement describes the surface characteristics of the pavement as a whole. Unlike microtexture, the macrotexture is visibly discernible. The friction provided by macrotexture is important for aircrafts travelling at high speeds and is therefore crucial for runway deceleration (braking wheels), acceleration and touchdown zones. As mentioned above, the macrotexture in the runway pavement creates channels for water to drain off the runway surface. This helps reduce the risk of aircrafts hydroplaning when they land. If existing pavement macrotexture is poor, sawing or creating grooves may help in improving the macrotexture. The grooves in the pavement increase the overall friction of the pavement, and should be oriented to provide drainage channels for surface contaminants. The grooves need to be cleaned regularly, to remove dust and rubber build up from landing aircraft tires (Pinto, 2012). Figure 2.5 shows the differences between smooth, harsh and polished microtexture and macrotexture.





SURFACE	MACRO (large)	MICRO (fine)
	rough	harsh
	rough	polished
	smooth	harsh
	smooth	polished

Figure 2.5 Close up of microtexture and macrotexture (AAFTP, 2007)

Increasing pavement microtexture contributes to runway friction by improving skid resistance of the pavement in dry conditions. Water and wet snow lubricate the surface of the aggregates, decreasing pavement friction. In wet conditions, pavement macrotexture works with the pressure from the aircraft tire to improve friction by providing paths for water to escape from between the tire and pavement surface interface. (Pinto, 2012).

Hydroplaning is a complex phenomenon which depends on several variables such as water film thickness, aircraft speed, tire pressure, tire tread condition and the micro and macrotexture properties of the pavement surface. During hydroplaning, the aircraft tire rides on the water film and skid resistance is virtually eliminated (Transport Canada, 2012). Pavement distresses which may lead to hydroplaning include rutting, other transverse profile distortions, inadequate cross slope and longitudinal profiles (which lead to poor drainage) and low friction characteristics of the pavement surface.

“The factors that affect pavement surface texture, which relate to the aggregate, binder, and mix properties of the surface material and any texturing done to the material after placement, are as follows:

- Maximum Aggregate Dimensions—The size of the largest aggregates in an asphalt concrete (AC) or exposed aggregate PCC pavement will provide the dominant macro- texture wavelength, if closely and evenly spaced.

- Coarse Aggregate Type—The selection of coarse aggregate type will control the stone material, its angularity, its shape factor, and its durability. This is particularly critical for AC and exposed aggregate PCC pavements.
- Fine Aggregate Type—The angularity and durability of the selected fine aggregate type will be controlled by the material selected and whether it is crushed.
- Binder Viscosity and Content—Binders with low viscosities tend to cause bleeding more easily than the harder grades. Also, excessive amounts of binder (all types) can result in bleeding. Bleeding results in a reduction or total loss of pavement surface micro-texture and macro-texture. Because binder also holds the aggregate particles in position, a binder with good resistance to weathering is very important.
- Mix Gradation—Gradation of the mix, particularly for porous pavements, will affect the stability and air voids of the pavement.
- Mix Air Voids—Increased air content provides increased water drainage to improve friction and increased air drainage to reduce noise.
- Layer Thickness—Increased layer thickness for porous pavements provides a larger volume for water dispersal. On the other hand, increased thickness reduces the frequency of the peak sound absorption.
- Texture Dimensions—The dimensions of PCC tining, grooving, grinding, and turf dragging affect the macro-texture, and therefore the friction and noise.
- Texture Spacing—Spacing of transverse PCC tining and grooving not only increases the amplitude of certain macro-texture wavelengths, but can affect the noise frequency spectrum.
- Texture Orientation—PCC surface texturing can be oriented transverse, longitudinal, and diagonally to the direction of traffic. The orientation affects tire vibrations and, hence, noise.
- Isotropic or Anisotropic—Consistency in the surface texture in all directions (isotropic) will minimize longer wavelengths, thereby reducing noise.
- Texture Skew—Positive skew results from the majority of peaks in the macro-texture profile, while negative skew results from a majority of valleys in the profile” (National Highway Cooperative Research Program [NCHRP], 2009).

Table 2.1 shows a summary of the factors which influence pavement microtexture and macrotexture.

Table 2.1 Factors affecting pavement microtexture and macrotexture (NCHRP, 2009)

Pavement Surface Type	Factor	Micro-Texture	Macro-Texture
Asphalt	Maximum aggregate dimensions		X
	Coarse aggregate types	X	X
	Fine aggregate types		X
	Mix gradation		X
	Mix air content		X
	Mix binder		X
Concrete	Coarse aggregate type	X (for exposed agg. PCC)	X (for exposed agg. PCC)
	Fine aggregate type	X	
	Mix gradation		X (for exposed agg. PCC)
	Texture dimensions and spacing		X
	Texture orientation		X
	Texture skew		X

The basic friction characteristics of the critical tire-pavement contact area influences the available friction that can be used by an aircraft. These basic friction characteristics are properties belonging to the individual components of a system as described in Table 2.2

The three main components of the system are:

- a) Surface friction characteristics (static material properties);
- b) Dynamic system (aircraft and pavement in relative motion); and
- c) System response (aircraft performance).

The aircraft response predominantly depends on the available tire-pavement friction and the aircraft anti-skid system (ICAO, 2012).

Table 2.2 summarizes the factors that influence pavement friction forces, grouped into four categories— pavement surface characteristics, vehicle operational parameters, tire properties, and environmental factors (NCHRP, 2009).

In regards to time and seasonal effects, as the pavement ages, the friction decreases as a result of three main factors:

- Aggregate polishing under traffic reducing microtexture;
- Aggregate wear under traffic reducing macrotexture; and
- Accumulation of contaminants (primarily rubber from aircraft tires).

Table 2.2 Factors influencing pavement friction (NCHRP, 2009).

Pavement Surface Characteristics	Vehicle Operating Parameters	Tire Properties	Environment
<ul style="list-style-type: none"> • Micro-texture • Macro-texture • Mega-texture/ unevenness • Material properties • Temperature 	<ul style="list-style-type: none"> • Slip speed <ul style="list-style-type: none"> > Vehicle speed > Braking action • Driving maneuver <ul style="list-style-type: none"> > Turning > Overtaking 	<ul style="list-style-type: none"> • Foot Print • Tread design and condition • Rubber composition and hardness • Inflation pressure • Load • Temperature 	<ul style="list-style-type: none"> • Climate <ul style="list-style-type: none"> > Wind > Temperature > Water (rainfall, condensation) > Snow and Ice • Contaminants <ul style="list-style-type: none"> > Anti-skid material (salt, sand) > Dirt, mud, debris

Note: Critical factors are shown in bold.

Rubber accumulation fills the voids in the macrotexture and microtexture, creating a smooth surface, which becomes especially slippery during wet conditions. The rate of rubber build up on the pavement surface and the rate of aggregate polishing are directly proportional to the volume of landings and the size and weight of aircrafts. Weather also impacts the rate of rubber accumulation (Pinto 2012).

On Runway 07-25 at Kuujuaq airport, rubber contamination accumulates predominantly during summer months (May-September) but is typically removed (almost entirely) during winter due to maintenance brooming operations.

Friction is the force developed between a pavement surface and a tire, which resists the motion of the moving tire. Friction increases rapidly with increasing slip to a peak value of between 10 and 20 percent slip, which is called the critical slip, as shown on Figure 2.6. At 100 percent slip, friction decreases to the coefficient of sliding friction. The difference between the peak and 100% sliding coefficients of friction can equal 50 percent of sliding value. On wet pavements, this disparity is greater (NCHRP, 2009).

Friction is comprised of two components: adhesion (F_a , which is function of microtexture) and hysteresis (F_h , a function of macrotexture). The total braking force, F , equals $F = F_a + F_h$ (NCHRP, 2009). Adhesion and hysteresis are shown on Figure 2.7.

Hysteresis is mostly related to macrotexture and is a force which occurs within the deflected visco-elastic tire tread. It is a function of speed. Adhesion is mostly related to microtexture. On wet pavements, adhesion decreases with increased speed and hysteresis increases with increased speed (NCHRP, 2009).

Friction provides importance in threshold but also helps in decelerating quickly. Thus, short runways must have high frictional properties.

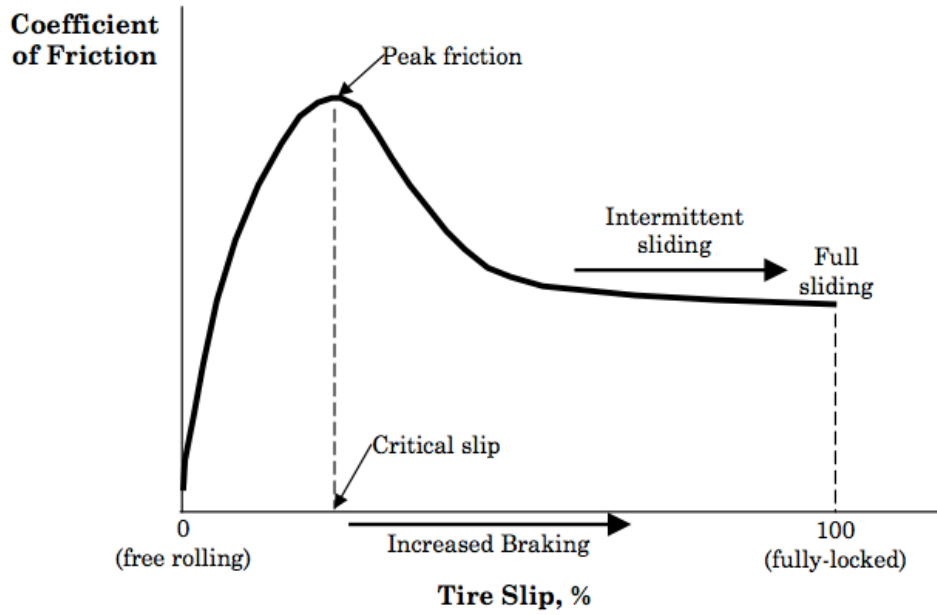

Figure 2.6 Coefficient of friction vs. tire slip (NCHRP, 2009).

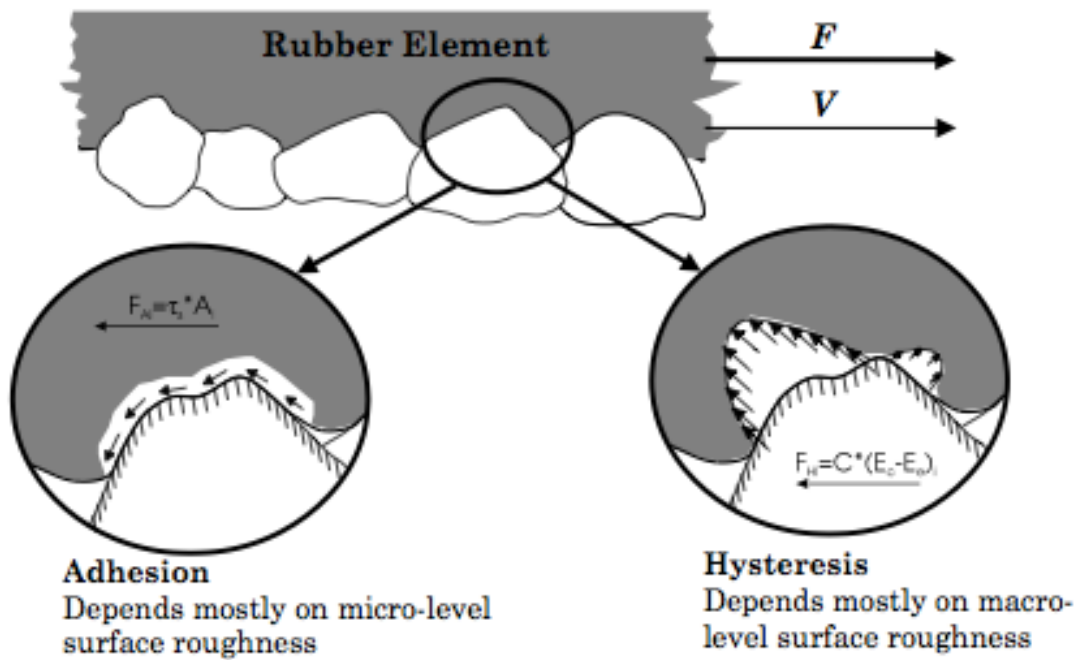

Figure 2.7 Key mechanisms of pavement-tire friction (NCHRP, 2009).

2.5.2 Case Study – Runway Overrun in St.John’s, Newfoundland

On July 16 2011, at 0645 Newfoundland Daylight Time, a Kelowna Flightcraft Air Charter Ltd. Boeing 727-281 departed Moncton International Airport in New Brunswick for St. John’s International Airport in Newfoundland and Labrador, on a scheduled cargo flight. There were three crew members on board. An instrument landing system approach was carried out and at 0809 the aircraft landed on Runway 11. After touchdown, the crew was not able to stop the aircraft before reaching the end of the runway. About 350 feet beyond the end of the runway pavement, the aircraft came to a stop in the grass. There were no injuries to any of the crew members and only minor damage was reported on the aircraft (Transportation Safety Board [TSB], 2011).

An investigation of this occurrence was completed by the Transportation Safety Board of Canada, for the purpose of advancing transportation safety.

The main findings of the investigation are as follow.

1. Hydroplaning

The aircraft touched down at about 1850 feet from the threshold, at a speed that was higher than required, which reduced the available runway length to bring the aircraft to a complete stop (TSB, 2011).

About 8 seconds after touchdown, the pilot applied the brakes and almost immediately noted that the aircraft was skidding. Braking was maintained throughout the landing roll until the aircraft came to a stop. Pieces of reverted rubber were found on the runway where the aircraft touched down and along the left side of the runway up to where the aircraft departed the pavement. This gives an indication that the aircraft experienced reverted rubber hydroplaning nearly immediately after applying the brakes and periodically throughout the landing roll (TSB, 2011).

If skidding is experienced after breaking, a typical recovery method is to completely release the brakes momentarily, in order to let the wheels spin up again and establish an adequate speed reference (TSB, 2011).

When hydroplaning occurs (a reduction of wheel contact and friction), a crosswind will exacerbate the aircraft’s tendency to weathervane into the wind. In addition, both smooth runway surfaces and tires with smooth treads will induce hydroplaning with lower water depths (TSB, 2011).

Although the exact depth of water could not be determined, it was confirmed that the presence of water on the runway caused the aircraft to hydroplane, which led to a loss of directional control and braking. This increased the required stopping distance for the

aircraft. The hydroplaning was exacerbated because the brakes were held throughout the landing roll and the tires had excessive tread wear (TSB, 2011).

2. Tire Wear

It was found that 3 of the 4 tires were more than 80% worn, while the 4th tire was about 65% worn. On a wet runway, once a tire is about 80% worn, the wet-runway friction significantly drops. Utilizing tires that are more than 80% worn reduces wet-runway friction which increases the risk of hydroplaning and possible runway overruns (TSB, 2011).

3. Wet Runways

Both the microtexture and macrotexture and characteristics of a pavement surface greatly affect its friction values. When TSB investigators touched the surface of runway 11/29, it was noted to be smooth, which is inconsistent with the gritty feeling of a good microtexture. Good microtexture is the primary means of preventing viscous hydroplaning. Both the FAA and ICAO recommend that a complete runway friction survey should include tests at both 65 km/h (for macrotexture condition) and 95 km/h (for microtexture condition). Although Advisory Circular AC 300-008 states that the quality of the runway surface (including the microtexture condition) may contribute to the runway's slipperiness under wet or dry conditions, TC does not require testing of microtexture on runways. The practice of not testing the microtexture on runways increases the risk of hydroplaning due to an incomplete assessment of the runway's overall friction characteristics (TSB, 2011).

4. Runway End Safety Area

One of the top safety issues requiring further action on TSB's Watchlist are runway overruns. TSB has identified safety areas beyond the runway's end as a key measure against damage and injuries resulting from overruns. TC has indicated its intent to meet the current ICAO standard for safety areas, however this has not yet occurred. The lack of adequate runway end safety areas (RESA) or other engineered systems increases the risk of aircraft damage and injuries to passengers (TSB, 2011).

5. Runway Grooving

The performance of aircraft landing on wet runways is a widely recognized safety concern. Grooves on runways improve surface drainage which in turn minimize skids and drifts, improve braking, and lower the risk of hydroplaning. Studies have shown that grooved runways during wet conditions often provide almost the same level of braking as dry runways. The use of non-grooved runways increases the risk of runway overruns in wet conditions due to reduced braking characteristics (TSB, 2011).

6. Anti-skid System

When firefighters arrived on site and assessed the aircraft, they noted that all 4 brakes were hot. This indicates that brake pressure was applied to all 4 brakes. The anti-skid control unit had to be serviceable at the time of the overrun in order for this to happen (TSB, 2011).

7. Runway Surface Condition Reporting

Runway landing distance is affected by contaminants such as rain, snow, ice, and slush. To provide an accurate assessment of the suitability of a runway for landing, there must be a clear understanding of the current condition of the runway, particularly when contaminants as listed above may be present on the runway surface. “The current runway surface condition (RSC) reporting standards and recommended practices are focused on winter conditions. These standards and recommended practices are ambiguous and lack clear direction regarding runway inspections during periods of heavy rain or in the presence of standing water on the runway. While it is understood that measuring the effects of water on runways presents certain challenges, the lack of clearly defined RSC reporting standards related to water on runways increases the risk of hydroplaning” (TSB, 2011).

This is an important topic in the case of Kuujuaq runway, since the presence of (and lack of) permafrost is one of the main causes of surface deformation and resulting water ponding on the runway.

2.6 Methods of Assessing Friction and Texture on Pavement Surfaces

Four methods of assessing pavement surface friction and texture (microtexture and macrotexture) are presented in the following sections.

2.6.1 British Pendulum Test

The British Pendulum Tester is also known as the Portable Skid Resistance Tester. Originally developed in the 1940s to measure slip resistance of floors in government buildings, it is currently used in laboratories as well as in the field, to measure the low-speed friction of a road surface material. Low speed friction is suggested to be mainly governed by the microtexture of a road material; hence the British Pendulum Tester is an indirect way to measure pavement microtexture. A schematic of a typical British Pendulum Tester is shown in Figure 2.8.

The British Pendulum Test, as described in ASTM Standard Test Method E 303, produces a sliding contact between the rubber slider of the test apparatus and the surface being tested. The surface is placed horizontally at the base of the test apparatus, and the

pivot point of the pendulum is adjusted so that the sliding distance of the rubber slider on the test surface covers a specified length. The test begins with the pendulum arm being held horizontally, which is then allowed to free fall under its own weight. After the sliding contact with the test surface, the pendulum arm will continue to swing upwards until it stops. The elevation at which the pendulum comes to a stop is calibrated to give a reading in British Pendulum Number (BPN). The BPN is a measure of the friction between the interface of the rubber slider and the test surface, and is used to indicate the level of skid resistance provided by the surface being tested (Liu, 2004).

British Pendulum Numbers (BPNs) do not necessarily correlate with other measures of frictional/slip resistance testing.

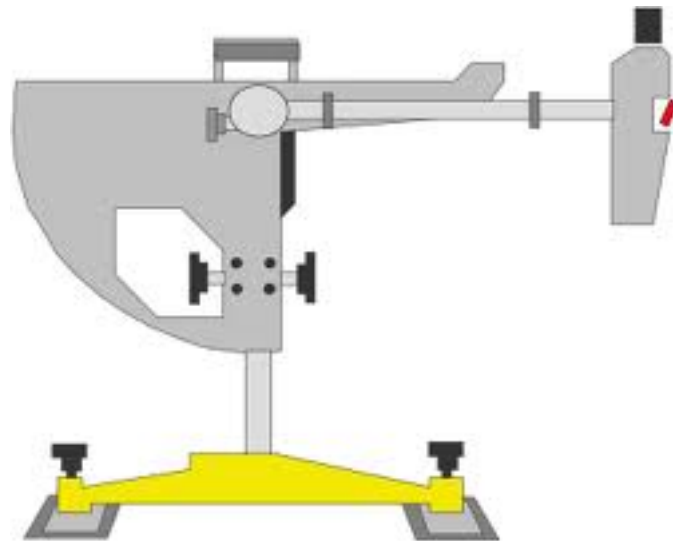

Figure 2.8 Schematic of British Pendulum Tester (FloorSlip UK, 2013)

2.6.2 Sand Patch Test

The Sand Patch test, as described in ASTM E 965, is a method for determining the average depth of pavement surface macrotexture. This test is performed by applying a known volume of a material (such as sand or glass beads) on the surface of a pavement and the subsequent measurement of the total area covered. It is designed to provide an average depth value of only the pavement macrotexture, and is considered insensitive to microtexture characteristics of the pavement. The results obtained using this method to calculate mean texture depth do not necessarily correlate directly with other methods used to determine mean texture depth (ASTM, 2006a).

The test consists of spreading a known volume of a material on a clean and dry pavement surface, measuring the area covered and subsequently calculating the average depth between the bottom of the pavement surface voids and the tops of the surface aggregate particles (ASTM, 2006a). A photograph of a sand patch test is shown in Figure 2.9.

This test method is suitable for field tests and is used to determine the average macrotexture depth of a pavement surface. Pavement macrotexture depth is used to characterize the pavement surface texture. When used in conjunction with other physical tests, the macrotexture depth values obtained from this test method may be used to determine the pavement skid resistance (ASTM, 2006a).



Figure 2.9 Sand Patch test (Field site visit, 2012)

2.6.3 Outflow Meter Test

The Outflow Meter test, as described in ASTM E 2380-05, measures the texture of a pavement surface as it relates to the drainage capability of the pavement through its surface and subsurface voids (macrotexture). The Outflow Meter device times how long it takes a known quantity of water (under gravitational pull) to escape through the voids in the pavement texture. It is intended to provide a measure of the ability of the pavement to relieve pressure from the face of vehicular tires and thus an indication of hydroplaning potential under wet conditions. A faster water escape time indicates a thinner film of water may exist between the tire and the pavement, thus more microtexture could be exposed to indent the face of the tire and more surface friction available to the tire. The less amount of seconds it takes to evacuate the water, the lower the water pressure under the tire (ASTM, 2005a). The results from this method are related to the mean texture depth (MTD).

The Outflow Meter apparatus consists of a transparent vertical cylinder that rests on a rubber annulus placed on the pavement, as shown in Figure 2.10. A valve on the bottom

of the cylinder is closed and the cylinder is filled with water. The valve is then opened and the time required for a specified volume of water to flow through the system is measured and called the outflow time (OFT). It provides an indication of pavement surface macrotexture characteristics (ASTM, 2005a).



Figure 2.10 Typical Outflow Meter apparatus (National Driller, 2001)

2.6.4 GripTester

The GripTester is a friction measuring instrument (shown in Figure 2.11) that measures the longitudinal skid resistance coefficient of a pavement continuously and dynamically, and results are expressed as Grip Number (GN) or GripTester Friction Number. Skid resistance is obtained from the friction force which exists between a partially locked wheel and the wet pavement surface (*Skid Resistance (Surface Friction) Tester*, n.d.).

This surface friction (skid resistance) tester has been supplied to highway and airport authorities since 1987, and is an internationally accepted device. In winter conditions, airport operators use the GripTester to provide friction data for their staff and for airlines (*Skid Resistance (Surface Friction) Tester*, n.d.).

Specified by ICAO and covered by BS7941-2:2000, the GripTester is the most widely used runway surface friction tester in the World. With over 450 units currently in operation worldwide, the GripTester provides users with the flexibility to undertake the level of runway surveys, which is most appropriate for the volume of air traffic handled (*Skid Resistance (Surface Friction) Tester*, n.d.).

As specified in the Transport Canada Aerodrome Safety Circular ASC 2004-024, the friction test tire which is used on the GripTester should be manufactured to meet the requirements of ASTM E1844. The pressure of the tire is specified at 138 +/- 3 kPa, and the vertical load on the friction test tire is 205 N. The test speed should be held constant at 65 +/- 5 km/h. The test tire is to be continuously braked during testing and should have a constant slip ratio of 10-20 percent. Testing is to be completed when the ambient air temperatures are above 0 degrees Celcius, and the pavement is dry or no more than “damp” prior to testing. “Damp” is when the pavement surface appears to be moist but a water thickness cannot be determined. The depth of water placed in front of the test tire by the self-wetting system should be 0.25 mm in thickness. Alternative water depths of 0.5 and 1.0 mm in thickness may also be used. Friction measurements should be taken on tracks parallel to the runway centerline, at left and right offsets of three meters for runways serving narrow body aircraft (Transport Canada, 2004). Other offsets such as 5 m, 10 m, 15 m may be tested to determine the friction at select locations away from the centreline.



Figure 2.11 Typical GripTester (*Skid Resistance (Surface Friction) Tester, n.d.*).

2.7 Aircraft Movements at Kuujjuaq Airport

The aircraft movements on a typical summer day on Runway 07-25 at Kuujjuaq Airport are summarized in Table 2.3.

Table 2.3 Type and amount of aircraft movements on Runway 07-25

Type of Aircraft	Number of Movements per Day
B767-200 (all cargo)	2
B737-200 (combined passenger and cargo)	4 to 8
CL60 (Government of Quebec - Medivac transportation)	2
DHC-8 (Dash-8, series 100 or 300)	2 to 5
DHC-6 (Twin Otter)	2 to 5
BE10 (Beechcraft King Air)	2 to 5
PC-12 (Pilatus)	1 to 3
C-172 (Cessna 172, and other light aircraft)	2 to 25

2.7 Current Methods of Snow Removal and Ice Control on Kuujuaq Runway

The current de-icing chemical used on Kuujuaq Runway 07-25 is the Safeway SF Runway de-icer. Safeway SF is a solid de-icer for runways and aprons, comprised of sodium formate, which acts as a freezing point depressant and melts ice and snow rapidly. When used in conjunction with the spreading equipment, it allows snow and ice to be cleared quickly. Like urea, Safeway SF is especially effective when used in conjunction with liquid runway de-icers. Safeway SF also gives long-term performance protection against ice and snow (Clariant, n.d.).

“Nunavik and Nunatsiavut have a rich natural heritage of lakes, rivers and wetlands that require ongoing stewardship and protection. Permafrost thaw lakes (thermokarst ponds) are a major classification of northern freshwater ecosystems, and they appear to be increasing in abundance and total surface area in parts of the circumpolar North, including Nunavik, as the permafrost continues to warm and degrade. The avoidance and mitigation of chemical pollution of northern aquatic ecosystems from both long-range and local sources requires ongoing vigilance” (Allard & Lemay, 2012).

Noting the above, this study will incorporate ways to decrease the usage of de-icing chemicals on Kuujuaq Runway 07-25 in the future by providing recommendations which ensure that the newly constructed/rehabilitated pavement will have good initial friction characteristics which will be preserved over its entire lifespan.

In addition to chemical de-icers, mechanical methods are used on the runway for the removal of frost, ice and snow. The equipment currently in use are towed-type sweepers (brooms), which are towed by snowplows. The snowplow is equipped with two types of blades, a power reversible and a roll over blade (see figure 2.12). Aggressive mechanical

methods of snow/ice removal on Kuujjuaq Runway 07-25 are thought to be decreasing microtexture and excessively increasing macrotexture.

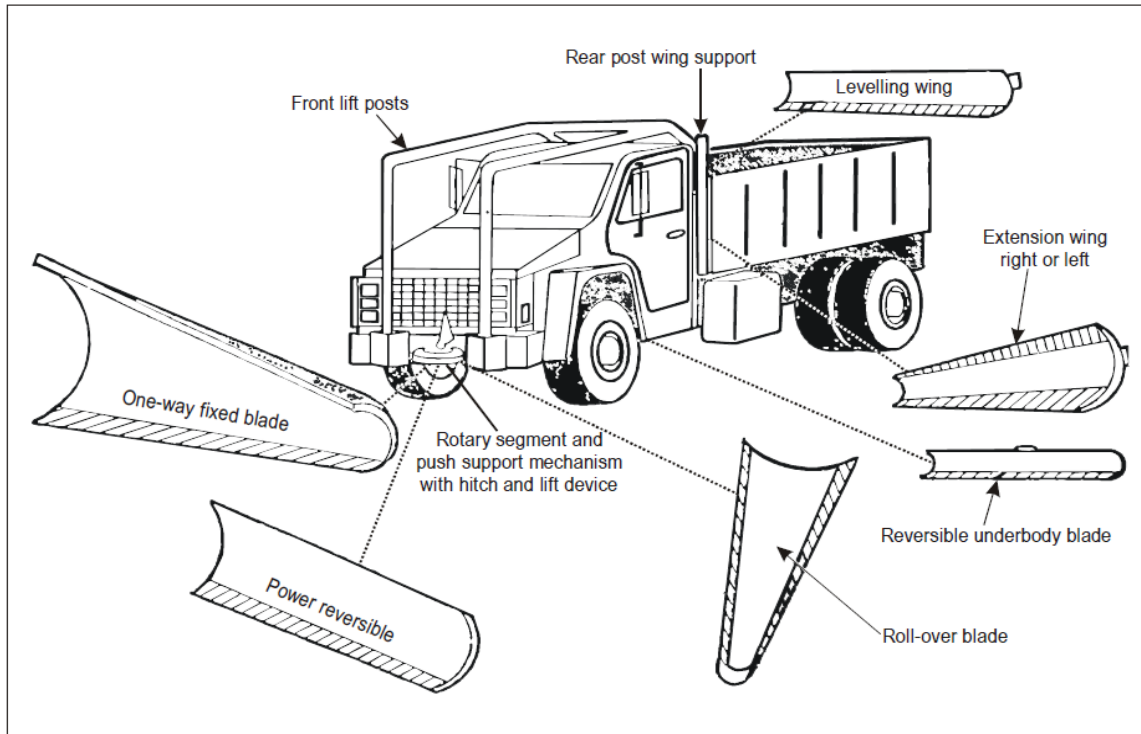

Figure 2.12 Snow removal blade types (International Civil Aviation Organization [ICAO], 2002)

2.8 Chapter Summary

In this chapter, a literature review was completed and the key findings are as follow. Kuujjuaq airport is an important gateway and regional hub between the south, the communities of Nunavik and Iqaluit to the north, providing an essential link for emergency evacuations, personal and business travel, as well as the transportation of basic food items. Kuujjuaq Runway 07-25 is of paramount importance to the community of Kuujjuaq and other communities in Nunavik.

The most affected by the impacts of climate change globally are the Inuit communities in Nunavik and Nunatsiavut. These communities are witnessing growing evidence of the impacts of accelerated warming in the region, which is expected to continue into the future. As a result of climate change, fluctuations in ambient temperatures drastically vary from year to year and also during a given year. Precipitation levels are increasing, and the amount of time which ice cover is present on the Koksoak River running parallel to Runway 07-25 has diminished, resulting in increased fog generation in the immediate area of the airport. When fog condenses and freezes on the runway surface, black ice forms. This, combined with unusual temperature variations during a given winter, results

in an augmented requirement for runway maintenance activities, which are necessary to remove the ice from the runway surface. The increased winter maintenance activities are resulting in diminishing pavement surface friction properties (decreasing microtexture and increasing macrotexture).

Runway pavement surface friction can be achieved through correct pavement mix designs and placement during construction. High friction can be achieved by properly engineering the aggregate macrotexture and microtexture in the pavement. Many surface features contribute to the overall pavement surface texture with different combinations of texture depth (amplitude) and feature length. These consist of microtexture, macrotexture and megatexture.

Hydroplaning is a complex phenomenon which depends on several variables such as water film thickness, aircraft speed, tire pressure, tire tread condition and the micro and macrotexture properties of the pavement surface. During hydroplaning, the aircraft tire rides on the water film and skid resistance is virtually eliminated. Pavement distresses which may lead to hydroplaning include rutting, other transverse profile distortions, inadequate cross slope and longitudinal profiles (which lead to poor drainage) and low friction characteristics of the pavement surface.

Friction is the force developed between a pavement surface and a tire, which resists the motion of the moving tire. Friction increases rapidly with increasing slip to a peak value of between 10 and 20 percent slip, which is called the critical slip. At 100 percent slip, friction decreases to the coefficient of sliding friction. The difference between the peak and 100% sliding coefficients of friction can equal 50 percent of sliding value. On wet pavements, this disparity is greater.

To assess pavement texture, the following tests may be used. The British Pendulum Test measures microtexture, by producing a sliding contact between a rubber slider and the surface being tested. The sand path test measures macrotexture by applying a known volume of a material (such as sand or glass beads) on the surface of a pavement, measuring the area covered and calculating the average depth between the bottom of the pavement surface voids and the tops of the surface aggregate particles. The outflow meter test measures the texture of a pavement surface as it relates to the drainage capability of the pavement through its surface and subsurface voids (macrotexture). The Outflow Meter device times how long it takes a known quantity of water under gravitational pull, to escape through the voids in the pavement texture and mean texture depth is subsequently calculated.

To assess pavement friction, the GripTester is the most widely used runway surface friction measuring device. It measures the longitudinal skid resistance coefficient of a

pavement continuously and dynamically. Skid resistance is obtained from the friction force which exists between a partially locked wheel and the wet pavement surface.

In addition to chemical de-icers, mechanical methods are used on Runway 07-25 at Kuujjuaq Airport for the removal of frost, ice and snow. The equipment currently in use are towed-type sweepers (brooms), which are towed by snowplows. The snowplow is equipped with two types of blades, a power reversible and a roll over blade. Aggressive mechanical methods of snow/ice removal on Kuujjuaq Runway 07-25 are thought to be decreasing microtexture and excessively increasing macrotexture.

Gaps identified in the literature review include cost effective pavement friction restoring methods which are optimal for runways in northern climates experiencing adverse effects of climate change. In the case of Kuujjuaq Runway 07-25, the recent friction safety concerns posed a need to evaluate the past and current friction characteristics of the pavement surface including microtexture and macrotexture. A thorough evaluation of the runway condition and determination of trends enabled the development of cost effective treatments for the friction restoration of this runway.

Chapter 3

Analysis and Discussion of Previous Field Testing Data

The purpose of this chapter is to provide an analysis of all of the available testing data from previous years on Kuujuaq Runway 07-25, in order to get an understanding of the past condition of the runway in terms of friction, texture, structural and surface condition, and in order to determine any past and current trends in surface friction characteristics.

3.1 Previous Friction Measurement Data on Kuujuaq Runway

Existing measurement data includes results from both Tradewind Scientific Ltd. and LVM inc. The data consists of the Outflow Meter test (2004, 2007 and 2011) and sand patch test (2012) for macrotexture; friction results (GripTester measurements from 2004, 2007 and 2011); FWD results (2010); and pavement condition survey in accordance with ASTM 5340 (2010).

In September of 2011, Tradewind Scientific Ltd. conducted a series of friction tests on the runway. The available tire-to-runway friction was quantified in this study, under controlled speed, water depth and test equipment configurations (Tradewind Scientific Ltd., 2011).

To obtain friction measurements, a GripTester (manufactured by Findlay Irvine Ltd. of Scotland) was used. The GripTester is an International Civil Aviation Organization (ICAO) listed and Federal Aviation Administration (FAA) approved friction measurement device. Tests were conducted in conformance with current standard test specifications for GripTester equipment, at 65 km/hr using a smooth-tread ASTM test tire, at 140 kPa inflation pressure under self-watering conditions at 0.25 mm water depth and at 3 m left and right offsets from the centerline of the runway (Tradewind Scientific Ltd., 2011).

In order to assess the pavement friction properties on the whole runway surface and under wet conditions at differing water depths and precipitation rates, tests were also performed at 0.25, 0.5 and 1.0 mm water layer depths at 1.5, 3, 5, 10 and 15 m left and right offsets from centreline, as well as under natural rain conditions (light and moderate). To ensure optimum performance, the equipment was calibrated prior to each set of tests (Tradewind Scientific Ltd., 2011).

Light rain describes rainfall which falls at a rate of between 0.1 and 2.5 mm per hour. Moderate rain describes rainfall which falls at a rate of between 2.6 and 7.6 mm per hour (American Meteorological Society, 2012).

The friction results show consistent runway profiles with minimum Grip Numbers in the touchdown zones for the runs close to the wheel path (1.5 to 5 m offsets). Average Grip Number values varied between 60 and 75, indicating generally good runway friction

properties with respect to Transport Canada Guidelines. The average and 100 m minimum values decreased with higher water depths, and the lowest numbers recorded were under moderate natural rain conditions, and under 1.0 mm applied water film tests (Tradewind Scientific Ltd., 2011).

Summaries of the results are presented in Figures 3.1 and 3.2.

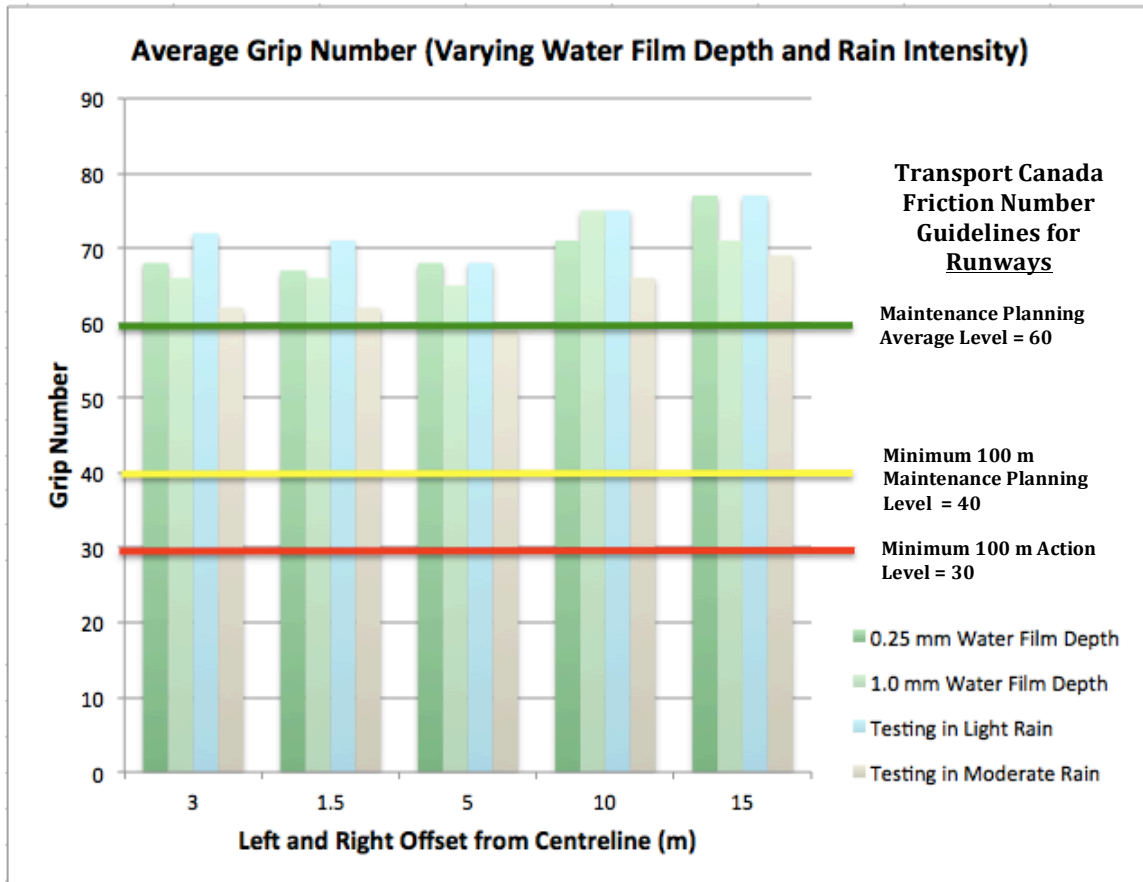

Figure 3.1 Average Grip Number measurement results under controlled self watering and varying rain conditions

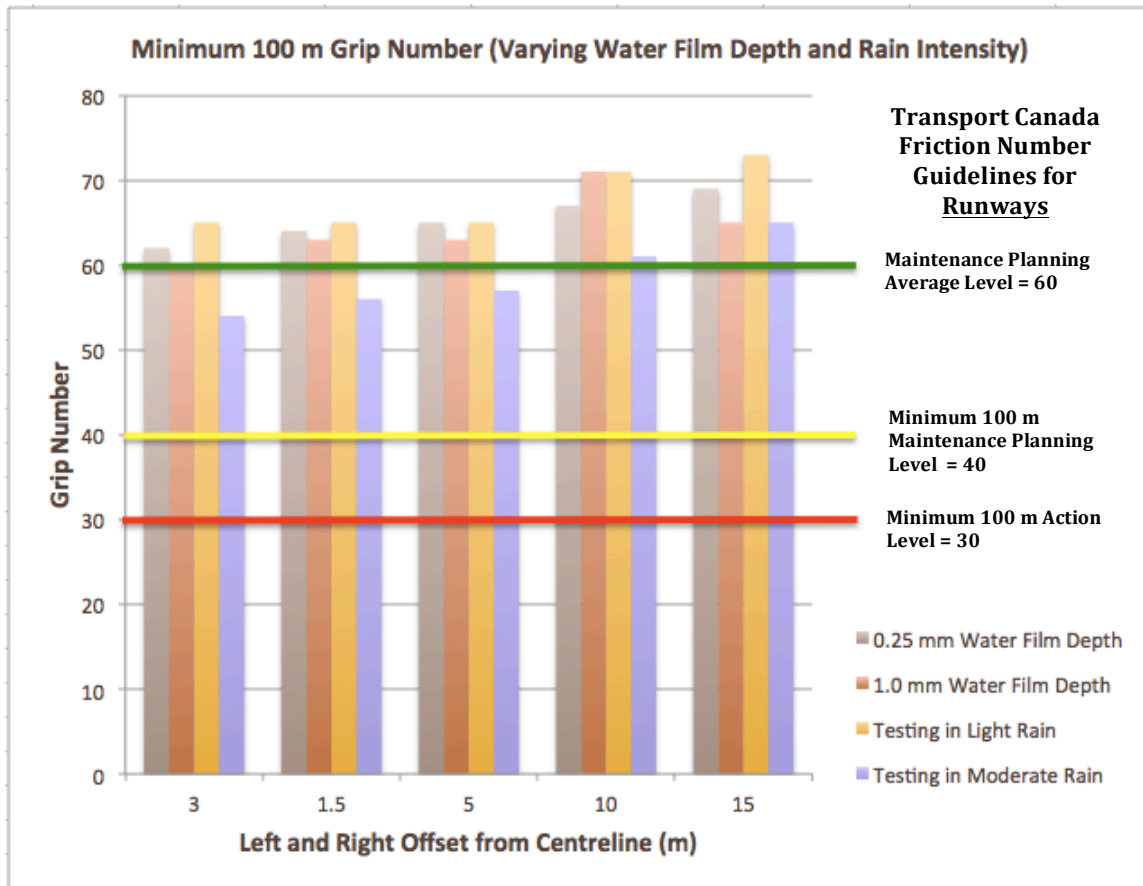

Figure 3.2 Minimum 100 m Grip Number measurement results under controlled self watering and varying rain conditions

Average Grip Numbers on the runway were generally in the range of 60-75, varying by centreline offset and applied or natural precipitation water depths. The lowest friction values were recorded in the wheel paths (1.5-5 m offset from centreline). The Grip Numbers decreased with increasing water film depth. The results from testing under moderate natural rain conditions were most comparable to; however, lower than, those at the higher water application rates. The Grip Numbers outside of the wheel paths (at 10 and 15 m offsets from centreline) were higher than the values in the wheel paths under comparable testing conditions (Tradewind Scientific Ltd., 2011).

The results recorded at 3 m left and right of the centreline with a 0.25 mm water depth showed an average Grip Number of 68 and a minimum 100 m section Grip Number of 62. This data is 5-10 points less than the values recorded in October 2007 (74 and 70) and June 2004 (78 and 71), indicating a declining trend (Tradewind Scientific Ltd., 2011).

Compared to the applicable Transport Canada Maintenance Planning Runway Average Guidelines, the measured Average Grip Number values and 100 m Minimum section

values were generally above the guidelines, except for the 5 m left and right offset testing under moderate rain conditions (an average grip number of 59) falling slightly below the maintenance planning average level. It should be noted that none of the results were below the minimum 100 m maintenance planning level and 100 m minimum action level. The Transport Canada Guidelines are summarized in Table 3.1 and shown on Figures 3.1 and 3.2.

Table 3.1 Transport Canada Friction Number guidelines (Tradewind Scientific Ltd., 2011)

Transport Canada Levels	GripTester Friction Number
Maintenance Planning Runway Average Level	60
Minimum 100 m Maintenance Planning Level	40
Minimum 100 m Action Level	30

Some runway rubber tire contamination and/or texture loss was observed from the friction measurements at both touchdown ends of the runway near the centreline. However, measurements of friction and texture were still above the acceptable guideline levels. It appears that the balance between traffic and maintenance activities results in generally good pavement friction, but there appears to be a decreasing trend since 2004. The decreasing trend can likely be attributed to traffic-related wear and surface contaminant build up affecting the runway surface microtexture. The macrotexture values in the wheel path area have been relatively stable over the years (Tradewind Scientific Ltd., 2011). However, as a result of recent aggressive brooming operations on the runway surface, macrotexture is thought to be excessively increasing and microtexture is rapidly decreasing.

As part of this study, a survey of the runway surface texture was also conducted, using an Outflow Meter according to ASTM Standard Test Method E2380-05. Figure 3.3 shows a plot of the survey results. Testing was completed at 5 m left and right offsets from the centreline, as well as along the centreline.

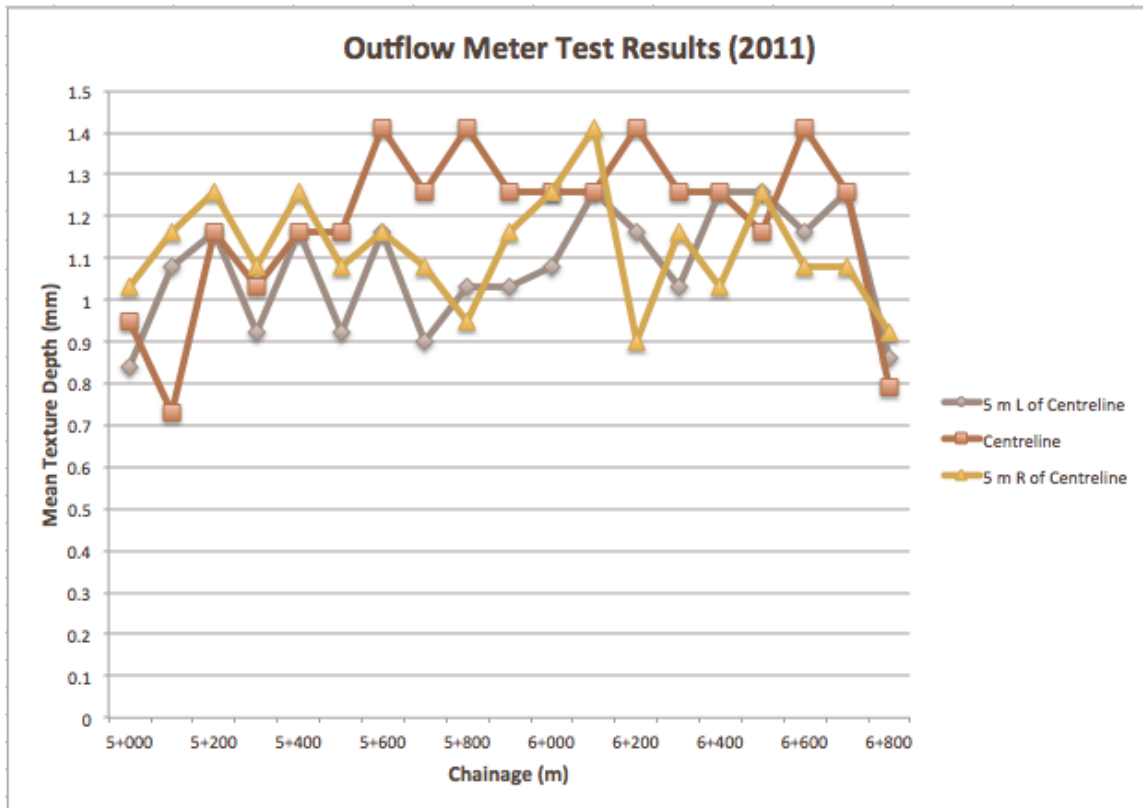

Figure 3.3 2011 Outflow Meter results (mean texture depth)

Calculated texture depths averaged approximately 1 mm or greater on most areas along the length of the runway, which meets or exceeds the ICAO and Transport Canada recommended texture values. The good microtexture and macrotexture confirm the moderate to high friction numbers recorded on the runway (Tradewind Scientific Ltd., 2011).

Texture surveys using the Outflow Meter test were also completed at 3 m left and right offsets from the centreline along the runway in 2004 and 2007, and a comparison was made. Figures 3.4 and 3.5 display how macrotexture has changed from 2004 to 2007. As shown by the graphs, macrotexture has generally increased from 2004 to 2007 along the length of the runway. This is likely due to the pavement surface undergoing aging by weather and winter maintenance activities such as brooming.

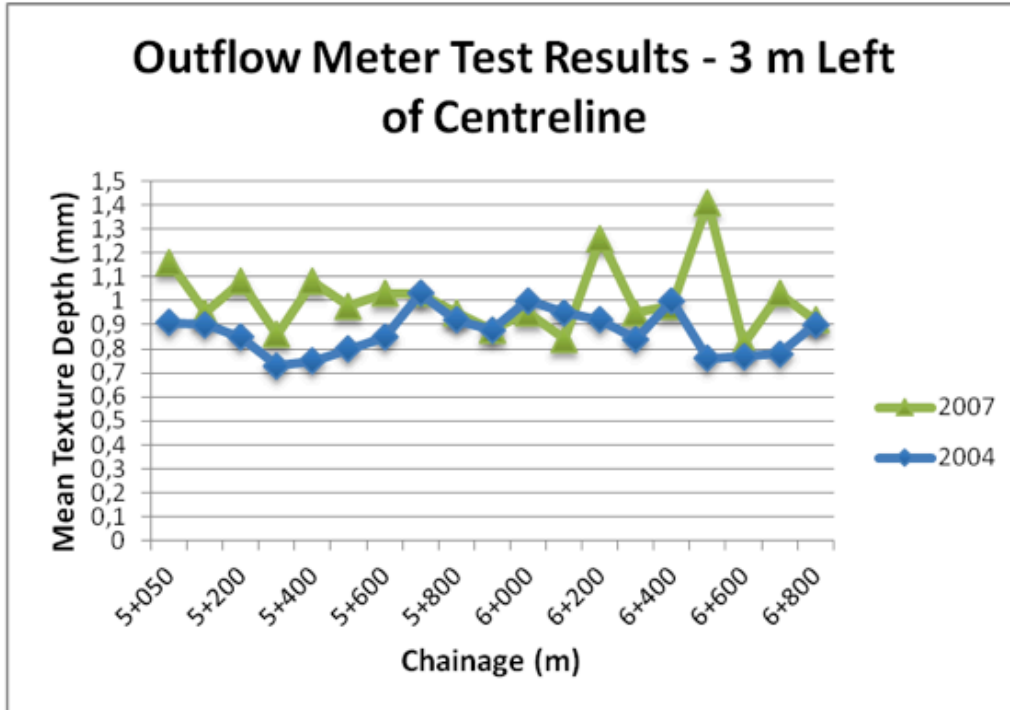

Figure 3.4 Mean texture depth, 3 m left of runway centreline

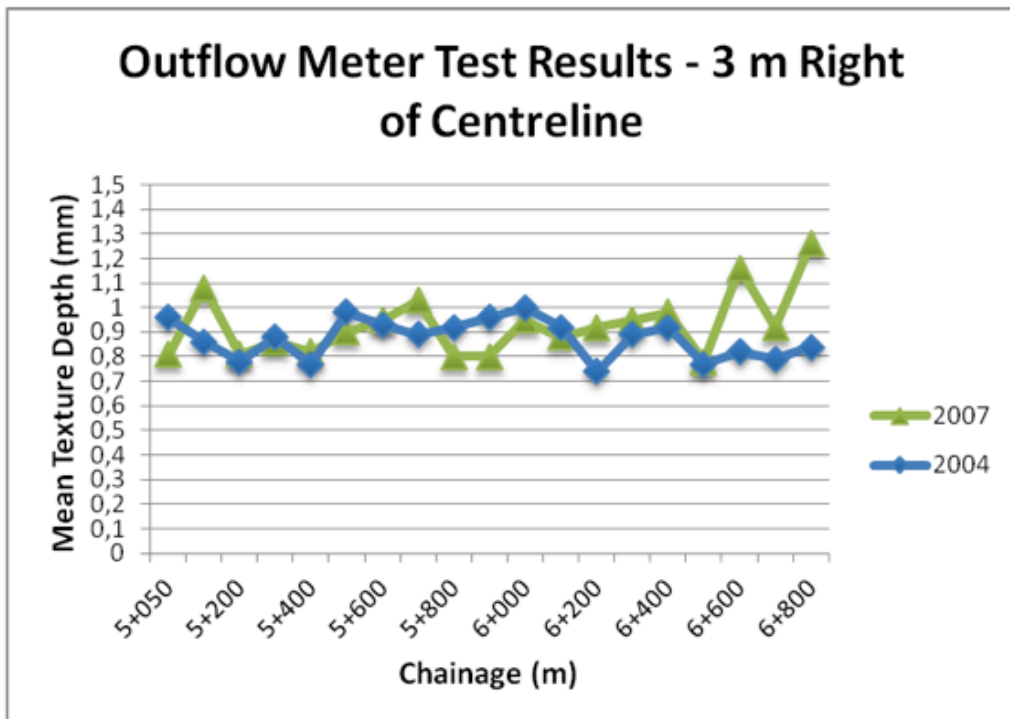

Figure 3.5 Mean texture depth, 3 m right of runway centreline

A comparison of the texture measurements from the years 2004, 2007 and 2011 shows that the average texture depths measured in the trafficked area of the runway (3 to 5 m offset from centreline) have remained close to 1 mm.

In September 2010, a pavement condition survey was completed in accordance with ASTM D5340 *Standard Test Method for Airport Pavement Condition Index Surveys*, by Dessau-JNA (ASTM, 2010).

The results of the survey showed that the condition of the runway is fair with some localized poor areas. The most significant distresses are low to medium severity longitudinal and transverse cracking, low severity longitudinal cracking (construction joints), localized low to high severity depressions at cracks and few areas of low severity alligator cracking towards the 25 end of the runway.

Falling Weight Deflectometer (FWD) testing was also completed in September 2010 by Dessau-JNA to assess the overall structural condition of the runway pavement. The testing device utilized was a Dynatest 8081 High Capacity Falling Weight Deflectometer.

The impulse stiffness modulus was calculated from the FWD load-deflection data and shown on a contour map with contours representing the approximate areas corresponding to five relative pavement support categories (the contour map from the Dessau-JNA 2010 report is provided in Appendix C). The impulse stiffness modulus represents a stiffness modulus of the combined pavement layers and subgrade, and provides an indication of the overall support characteristics of the pavement.

The results indicate that the majority of the runway has medium (with localized high and low) pavement support characteristics. The impulse stiffness modulus of the pavement along the centreline of the runway was about 100-140 kN/mm, with some localized areas with higher values (140 to 200 kN/mm). The right edge of the runway (river side) showed lower modulus values of 50-80 kN/mm, likely due to the thawing of permafrost and poor drainage. The structural pavement support in this area is poorer than anticipated and should be addressed during rehabilitation.

3.2 December 2012 Site Inspection

In December 2012, a site inspection was completed by Dr. Susan Tighe and Karolina Konarski from the University of Waterloo, Luc Chartrand from Dessau-JNA and Andre Leclerc and Fiona Beaudoin from Transport Canada. In addition to an overall visual survey of the runway, some preliminary sand patch testing was completed. Five sand patch tests were taken at various locations along the runway:

- In the touchdown zone at chainage 5+335, to the right of a centreline crack;

- Near chainage 5+730 in the breaking zone, on the centreline;
- Near chainage 5+735 on the left side of the runway where fewer brooming passes occur;
- Near chainage 6+170 where low severity fatigue cracking was observed in the right wheel path; and
- Near chainage 6+260 in the left wheel path of the breaking zone.

Results of the sand patch testing (calculated mean texture depths) are shown in Table 3.2.

Table 3.2 2012 Texture survey results

Distance from Centreline	Chainage (m)	Calculated Mean Texture Depth (mm)
0	5+335	0.77
0	5+730	1.15
20 m L	5+735	0.81
3 m R	6+170	0.76
3 m L	6+260	1.17

The results show that the pavement surface texture is generally high, and are comparable to the mean texture depths found during testing by Tradewind Scientific in 2011. The largest texture depths occur near the centreline, at chainages 5+730 and 6+260. Additional tests were completed to draw further conclusions on the trends with respect to pavement surface texture on the different sections of the runway. This more extensive texture testing was completed on the runway in the fall of 2013 (see Chapter 5), including additional sand patch, Outflow Meter, and British Pendulum testing.

After a general overview of the whole runway, spot checks were performed on areas of interest. Pavement surface texture was inspected; macrotexture was visually inspected and microtexture was felt by hand. In addition, surface distresses were noted (sealed and extensively patched transverse (mainly thermal) cracking at regular intervals along the length of the runway, longitudinal cracking (construction joints and centreline cracking, partially sealed), and low severity fatigue cracking in the wheel paths towards the 25 end of the runway, in areas of taxiing aircraft).

The snow removal equipment (snow ploughs and sweepers) used in regular operation at Kuujjuaq Airport was shown to the team by the Kuujjuaq Airport maintenance staff; the equipment was also observed operating on the runway.

Figure 3.6 shows photographs from the December 2012 site visit showing sand patch testing and winter maintenance equipment operating on the runway.



Photograph 1: Touchdown zone near the end of runway 07; location of first sand patch test



Photograph 2: Runway brooming operations



Photograph 3: Sand patch test in area of fatigue cracking on runway



Photograph 4: Close up of brooming equipment

Figure 3.6 Photographs from December 2012 site inspection

3.3 Chapter Summary

In this chapter, Runway 07-25 surface friction and texture testing data from previous is evaluated for past condition and trends.

Previous testing data includes results from both Tradewind Scientific Ltd. and LVM inc. The data consists of the Outflow Meter test (2004, 2007 and 2011) and sand patch test (2012) for macrotexture; friction results (GripTester measurements from 2004, 2007 and

2011); FWD results (2010); and pavement condition survey in accordance with ASTM 5340 (2010).

The friction results seem to be consistent along the length of the runway with minimum Grip Numbers in the touchdown zones for the runs close to the wheel paths (1.5 to 5 m offsets from centreline). Average Grip Number values varied between 60 and 75, indicating generally good runway friction properties with respect to Transport Canada Guidelines. Friction values decreased with higher water depths, and the lowest numbers recorded were under moderate natural rain conditions, and under 1.0 mm applied water film tests.

The results recorded at 3 m left and right of the centreline with a 0.25 mm water depth showed an average Grip Number of 68 and a minimum 100 m section Grip Number of 62. This data is 5-10 points less than the values recorded in October 2007 (74 and 70) and June 2004 (78 and 71), indicating a declining trend.

Compared to the applicable Transport Canada Maintenance Planning Runway Average Guidelines, the measured Average Grip Number values and 100 m Minimum section values were generally above the guidelines, except for the 5 m left and right offset testing under moderate rain conditions (an average grip number of 59) falling slightly below the maintenance planning average level. It should be noted that none of the results were below the minimum 100 m maintenance planning level and 100 m minimum action level.

It appears that the balance between traffic and maintenance activities results in generally good pavement friction, but there appears to be a decreasing trend since 2004. The decreasing trend can likely be attributed to traffic-related wear and surface contaminant build up affecting the runway surface microtexture. The macrotexture values in the wheel path area have been relatively stable over the years. However, as a result of recent aggressive brooming operations on the runway surface, macrotexture is thought to be excessively increasing and microtexture is rapidly decreasing.

In 2011 a survey of the runway surface texture was also conducted, using an Outflow Meter, at 5 m left and right offsets from the centreline, as well as along the centreline. Calculated texture depths averaged approximately 1 mm or greater on most areas along the length of the runway, which meets or exceeds the ICAO and Transport Canada recommended texture values. The good microtexture and macrotexture confirm the moderate to high friction numbers recorded on the runway.

Texture surveys using the Outflow Meter test were also completed at 3 m left and right offsets from the centreline along the runway in 2004 and 2007. Macrotexture has generally increased from 2004 to 2007 along the length of the runway. This is likely due to the pavement surface undergoing aging by weather and winter maintenance activities such as brooming.

A comparison of the texture measurements from the years 2004, 2007 and 2011 shows that the average texture depths measured in the trafficked area of the runway (3 to 5 m offset from centreline) have remained close to 1 mm, indicating a good macrotexture condition.

Chapter 4

Analysis and Discussion of Laboratory Testing Results

In March 2013, asphalt samples were obtained by Kuujjuaq Airport personnel and shipped to the LVM Toronto laboratory to complete laboratory testing; it is understood that the samples were obtained from a stockpile of the same asphalt mix that was used on Runway 07-25. The objective of the testing on the asphalt concrete samples was to provide additional data about the runway asphalt concrete characteristics.

The following tests were completed on the samples (on the surface course only): Extraction and gradation (% asphalt content and aggregate gradation); Marshall Properties (Bulk Relative Density, Maximum Relative Density, Air Voids (%), Flow (mm), Stability (N) and Voids in Mineral Aggregate (VMA) (%)), In-situ Pavement Compaction Determination; PGAC classification (including penetration); and British Pendulum Testing (British Pendulum Number, BPN).

4.1 Existing Asphalt Concrete Specifications for Kuujjuaq Airport

Existing project specifications, as per Dessau-Soprin/Papak Rapport No 2, *Reconstruction de la piste 07-25 Aeroport de Kuujjuaq*, Projet 674832-E3, dated November 2000, for the mix design and paving of Kuujjuaq runway were reviewed and summarized in the following sections. It should be noted that both 50 and 75 blows of the Marshall Compaction Hammer were used in the mix design. The laboratory testing undertaken in April 2013 also used 50 and 75 blows.

4.2 Asphalt Cement Content and Gradation

4.2.1 Asphalt Content

The test for extraction of asphalt cement (bitumen) was performed in accordance with ASTM D2171-05 *Standard Test Methods for Quantitative Extraction of Bitumen From Bituminous Paving Mixtures* (ASTM, 2005b).

This test method determines the quantity of bitumen in hot-mixed paving mixtures/pavement samples. The aggregates obtained from the sample during this test were used for sieve analysis testing, presented in Section 4.2.2.

The sample was extracted using normal Propyl Bromide. The bitumen content was calculated by taking the difference between the total mass and the mass of the extracted aggregate, moisture content, and mineral matter in the extract. The bitumen content is expressed as mass percent of the moisture-free mixture (ASTM, 2005b).

The calculated bitumen content for the two samples tested, Test 1 and 2 were 5.69, 5.67 percent, respectively. Average bitumen content was 5.68 percent.

Table 4.1 shows the project specifications (as per Dessau-Soprin/Papak Rapport No 2, *Reconstruction de la piste 07-25 Aeroport de Kuujjuaq*, Projet 674832-E3) with the 2013 lab testing results in the right part of the table for comparison.

Table 4.1 Comparison of test results in Year 2000 vs. 2013 – % asphalt cement

	Surface Course			Lab Testing Results (2013)	
	Results (year 2000)	Formula	Requirements	Test 1	Test 2
% Asphalt Cement	5.45	5.5	-	5.69	5.67

4.2.2 Gradation

Gradation of the aggregates in the mix was completed in accordance with ASTM C136 – 06 *Standard Test Method for Sieve Analysis of Fine and Coarse Aggregates* (ASTM, 2006d). This test determines the particle size distribution of the fine and coarse aggregate by sieving. Gradation results as compared with project specifications are shown in Table 4.2. Generally the results meet the project requirements, except for sieve size 12.5 mm, results show 97.5 and 97.2 percent passing (slightly coarser than project requirements).

Table 4.2 Comparison of gradation test results/requirements in Year 2000 vs. 2013

Sieve Size (mm)	Percent Passing (Surface Course)			Percent Passing (2013)	Percent Passing (2013)
	Results (year 2000)	Formula	Requirements	Test 1	Test 2
12.5	100	100	100	97.5	97.2
9.5	94	92		93.6	92.7
4.75	59.9	59	55-75	61.6	59.7
2	41	42	35-55	42.3	41.5
1.18	31	32		33.2	32.6
0.6	20	21		24	23.5
0.425	16	19	15-30	21.5	18.9
0.18	9	10	5-20	12.2	11.1
0.075	0.45	5.7	3-8	6.6	6.3

4.3 Marshall Properties

4.3.1 Preparation of Specimens Using Marshall Apparatus

To determine the Marshall properties (Bulk Relative Density, Maximum Relative Density, Air Voids (%), Flow (mm), Stability (N) and Voids in Mineral Aggregate (VMA) (%)) the samples were prepared in accordance with ASTM D6926-04 *Standard*

Practice for Preparation of Bituminous Specimens Using Marshall Apparatus (ASTM, 2004).

The samples were prepared into 102 mm diameter by 64 mm high cylindrical specimens by means of the original manual Marshall method. The samples obtained from the runway were heated in covered containers in an oven to a temperature of between 120°C and 135°C, until a loose mixture condition was obtained. The specimens were then placed in moulds and compacted as per the specification (ASTM, 2004). Table 4.3 shows the project specifications (as per Dessau-Soprin/Papak Rapport No 2, *Reconstruction de la piste 07-25 Aeroport de Kuujuaq*, Projet 674832-E3) with the 2013 lab testing results in the right part of the table for comparison. It appears that % air voids are out of specification for the 2013 test results.

Table 4.3 Comparison of marshall properties in Year 2000 vs. 2013

Test	Surface Course			Lab Testing Results (2013)	
	Results (year 2000)	Formula	Requirements	50 Blows	75 Blows
% Air Voids	3.8	2.6	2.0-4.0	1.8	1
Marshall Stability (N)	8330	11190	9000 min	16136	17927
Flow (mm)	2.5	3	2.0-4.0	3.7	3.8
VMA (%)	15.7	15	15 min	15.6	14.9

Figure 4.1 shows the Marshall Compaction Hammer used to compact the specimens.

4.3.2 Marshall Stability and Flow

Marshall Stability (N) and Flow (mm) were determined in accordance with ASTM D 6927-06 *Standard Test Method for Marshall Stability and Flow of Bituminous Mixtures* (ASTM, 2006b). This test determines the resistance to plastic flow of 102 mm cylindrical specimens loaded in a direction perpendicular to the cylindrical axis using the Marshall Apparatus. Marshall stability and flow, density and air voids are used for laboratory mix design and evaluation of existing mixtures.

Marshall Stability is the peak resistance load obtained during a constant rate of deformation loading. The magnitude of Marshall Stability varies with the aggregate type and grading, and type, grading, and amount of asphalt cement in the mixture (ASTM, 2006b).



Figure 4.1 Marshall compaction hammer (LVM Toronto laboratory, 2013)

Marshall Flow is a measure of deformation (elastic and plastic) of the mixture determined during the Stability test. Marshall flow is the total sample deformation from the point where the projected tangent of the linear part of the curve intersects the x-axis (deformation) to the point where the curve starts to become horizontal (corresponds to peak stability) (ASTM, 2006b).

Figure 4.2 shows the Marshall Stability machine, used to determine the Stability and Flow of the specimens.

The results show that flow values (mm) were 3.7 for 50 blows and 3.8 for 75 blows. Stability values were 16136 N for 50 blows and 17927 N for 75 blows.

It should be noted that Stability of reheated and recompacted mixtures from existing pavements is likely to be higher than the original mixture due to in service hardening of the binder (ASTM, 2006b). In this case, the stability values were in fact higher than the original testing performed in 2000.



Figure 4.2 Marshall Stability machine (LVM Toronto laboratory, 2013)

4.4 Bulk Relative Density

Bulk relative density was determined in accordance with ASTM D 2726-05a *Standard Test Method for Bulk Specific Gravity and Density of Non-Absorptive Compacted Bituminous Mixtures* (ASTM, 2005c). This test determines the bulk specific gravity and density of compacted bituminous mixtures.

During this test, the specimens (prepared as per Section 4.3.1) are immersed in a water bath at 25°C. The mass of the specimen under water is recorded, and the specimen is then weighed in air (after being quickly blotted with a damp cloth) and recorded. The difference between the two masses is used to measure an equal volume of water at 25°C. The mass of the thoroughly dried specimen is also recorded, and specific gravity (and density) is calculated using these values. Density is calculated by multiplying the specific gravity of the specimen by the density of water (ASTM, 2005c).

Figure 4.3 shows the scale used to record the weight of the specimens.



Figure 4.3 Scale for weighing specimens (LVM Toronto laboratory, 2013)

The bulk relative density was found to be 2.468 kg/m^3 for 50 blows and 2.489 kg/m^3 for 75 blows.

4.5 Maximum Relative Density

The maximum relative density was determined in accordance with ASTM D 2041-03a *Standard Test Method for Theoretical Maximum Specific Gravity and Density of Bituminous Paving Mixtures* (American Society of Testing and Materials [ASTM], 2003). This test determines the theoretical maximum specific gravity and density of uncompacted bituminous paving mixtures at 25°C .

A sample of oven-dry paving mixture in the loose condition is weighed and placed in a tared vacuum vessel. Water at a temperature of 25°C is added to the vacuum vessel so that the sample is completely submerged. Vacuum is gradually applied to reduce the residual pressure in the vacuum vessel to 4 kPa or less and then held for 15 ± 2 minutes. At this point the vacuum is gradually released. The volume of the sample of paving mixture is obtained by immersing the vacuum container with the sample in a water bath

and weighing it, or by filling the vacuum container full of water and weighing in air. Both the temperature and mass are measured. From mass and volume measurements, the specific gravity or density at 25°C is calculated (ASTM, 2003).

Figure 4.4 shows the Maximum Relative Densometer machine used to apply the vacuum to the vessel.



Figure 4.4 Maximum Relative Densometer tester (LVM Toronto laboratory, 2013)

The maximum relative density was found to be 2.513 kg/m³.

4.6 Air Voids

The air voids content was determined in accordance with ASTM D 3203-05 *Standard Test Method for Percent Air Voids in Compacted Dense and Open Bituminous Paving Mixtures* (ASTM, 2005d). This test determines the percent of air voids in compacted bituminous mixtures.

Air voids is calculated based on the results from Sections 4.4 and 4.5.

$$\%AirVoids = 100 * (1 - BRD / MRD)$$

Where BRD is bulk relative density and MRD is maximum relative density.

The air voids were found to be 1.8% for 50 blows, and 1.0% for 75 blows.

4.7 In-Situ Pavement Compaction

In order to determine the in-situ pavement compaction, the bulk relative density and maximum relative density are determined directly from the samples (without Marshall preparation). The test methods to determine bulk and maximum relative densities are described in Sections 4.4 and 4.5, respectively.

Percent compaction is calculated using the following formula.

$$\%Compaction = 100 * (BRD / MRD)$$

Where BRD is bulk relative density and MRD is maximum relative density.

Bulk relative density was found to be 2.313 and 2.342 kg/m³ for Tests 1 and 2, respectively. Maximum relative density was 2.537 and 2.538 kg/m³ for Tests 1 and 2, respectively.

Percent compaction was calculated to be 91.2 and 92.3% for Tests 1 and 2, respectively.

4.8 Asphalt Binder PGAC Classification

The Performance-Graded Asphalt Binder test was performed in accordance with AASHTO M320-05 (American Association of State Highway and Transportation Officials [AASHTO], 2005). Grading designations are related to the average seven-day maximum pavement design and one-day minimum pavement design temperatures, and using Table 1 in the AASHTO M320-05 specification.

Prior to completing this test, a penetration test was completed in accordance with ASTM D 5-06 *Standard Test Method for Penetration of Bituminous Materials* (ASTM, 2006c). This test determines the penetration value of semi-solid and solid bituminous materials.

To complete this test, the sample was melted and cooled under controlled conditions. The penetration was measured with a penetrometer (a standard needle applied to the sample under specific conditions). The penetration test is used to measure consistency; higher penetration values indicate a softer consistency (ASTM, 2006c). Figure 4.5 shows the penetration test equipment.



Figure 4.5 Penetration test equipment (LVM Toronto laboratory, 2013)

The procedure consists of melting and cooling the asphalt binder into a container of specified dimensions. A needle is penetrated into the sample under the following conditions: 25°C temperature, 100 g load and a penetration time of 5 seconds, then depth of penetration is recorded. The depth of penetration is measured in units of 0.1 mm and reported in penetration units (for instance, if the needle penetrates 8 mm, the asphalt penetration number is 80). The Bending Beam Rheometer and Dynamic Shear Rheometer machines were used to obtain the information required to classify the asphalt binder. Figures 4.6 and 4.7 show the machines.



Figure 4.6 Bending Beam Rheometer (LVM Toronto laboratory, 2013)



Figure 4.7 Dynamic Shear Rheometer (LVM Toronto laboratory, 2013)

Results from the testing indicate that penetration was 33 mm and the PGAC grade was 52-23. Comparing to the original PGAC specification of 52-34, the lab testing result is reasonable as the binder is 13 years old and has oxidized, resulting in a higher low temperature grade.

4.9 British Pendulum Test

British Pendulum Testing was completed in accordance with ASTM E 303-93 (Reapproved 2008) *Standard Test Method for Measuring Surface Frictional Properties Using the British Pendulum Tester* (ASTM, 2008). This test measures the surface frictional properties using the British Pendulum Skid Resistance Tester, as described in Section 2.6.1. Figure 4.8 shows the British Pendulum Tester used to complete the testing.

Testing was completed on three samples of the surface course. Results are presented in Table 4.4. Of the three samples, the results show that the average British Pendulum Number (BPN) in a wet condition is 60.

The test results have been compared to the BPN values of some typical mixes, specifically, newly prepared HL 3 Fine, Superpave 12.5 FC2 and Superpave 19 hot-mix asphalt samples (presented in Table 4.5 below). The test results indicate that the frictional properties of the Kuujuaq runway samples are most comparable to, but lower than, that of HL 3 Fine hot-mix asphalt.

Table 4.4 British Pendulum test results of Kuujuaq asphalt samples

Sample Number	Surface Condition	Surface Temperature (°C)	Average BPN*
1	Wet	22.0	59
2	Wet	22.0	61
3	Wet	22.0	60

* British Pendulum Number

Table 4.5 British Pendulum test results of typical asphalt concrete mixes

Type of Specimen	Surface Condition	Average BPN*
LVM HL3 Fine HMA sample	Wet	66
LVM Superpave 12.5 FC2 HMA sample	Wet	73
LVM Superpave 19 HMA sample	Wet	75

* British Pendulum Number



Figure 4.8 British Pendulum Tester (LVM Toronto laboratory, 2013)

4.10 Chapter Summary

This chapter provides the results of the 2013 laboratory testing completed on asphalt concrete samples obtained from Kuujuaq Airport which are of the same mix as was used on Runway 07-25. The objective of the testing was to provide additional data about the runway asphalt concrete characteristics.

The following tests were completed on the samples (of the surface course only): Extraction and gradation (% asphalt content and aggregate gradation); Marshall Properties (Bulk Relative Density, Maximum Relative Density, Air Voids (%), Flow (mm), Stability (N) and Voids in Mineral Aggregate (VMA) (%)); In-situ Pavement Compaction Determination; PGAC classification (including penetration); and British Pendulum Testing (British Pendulum Number, BPN).

The asphalt cement content for the two samples tested, Test 1 and 2, was determined to be 5.69, 5.67 percent, respectively. The average asphalt cement content was 5.68 percent.

Aggregate gradation results generally met the project requirements (as per Dessau-Soprin/Papak Rapport No 2, *Reconstruction de la piste 07-25 Aeroport de Kuujjuaq*, Projet 674832-E3), except for sieve size 12.5 mm, showing 97.5 and 97.2 percent passing (slightly coarser than project requirements of 100 percent passing).

Marshall Stability, Flow and VMA all generally met project specifications except for air voids, which were lower than the project specifications (1.8% for 50 blows, and 1.0% for 75 blows). The bulk relative density was found to be 2.468 kg/m³ for 50 blows and 2.489 kg/m³ for 75 blows. The maximum relative density was found to be 2.513 kg/m³. Percent compaction was calculated to be 91.2 and 92.3% for Tests 1 and 2, respectively.

The penetration testing result was 33 mm and the PGAC grade of the asphalt was determined to be 52-23. Comparing to the original PGAC specification of 52-34, the lab testing result is reasonable as the asphalt binder is 13 years old and has oxidized, resulting in a higher low temperature grade.

British Pendulum testing was completed on three samples of the surface course. Results show that the average BPN is 60 and that frictional properties of the Kuujjuaq runway samples are most comparable to, but lower than, that of HL 3 Fine hot-mix asphalt.

Chapter 5

2013 Field Testing Data Analysis and Discussion

Field testing was completed in August and September of 2013 on Runway 07-25 of Kuujjuaq Airport. The types of tests completed were Sand Patch and Outflow Meter for macrotexture, British Pendulum for microtexture and GripTester for surface friction. In addition, core samples were obtained from multiple locations on Kuujjuaq runway for visual examination.

The main objective of this field testing was to collect a complete set of current and relevant field data related to pavement surface texture and friction in order to complete analyses and gain an understanding of current runway conditions. The analyses were used to help in developing the options for improving the pavement surface friction on Runway 07-25 and to mitigate the impacts of climate change on the pavement surface friction characteristics.

Sand Patch and Outflow Meter testing were generally completed at intervals of 250 m along the runway, staggered at 125 m intervals. Where possible, additional tests were completed in between these intervals. Tests were completed along lines 3 m, 7 m, 10 m and 20 m left and right of the centerline as well as along the centreline. This testing was completed to compare macrotexture results from previous years and to monitor the effects of winter maintenance brooming and wear on macrotexture.

British Pendulum testing was generally completed at intervals of 125 m along the length of the runway, with additional tests completed at 62.5 m intervals from stations 5+500 to 6+375. Tests were completed along lines 3 m, 7 m, 10 m and 20 m left and right of the centerline as well as along the centreline. This testing was completed to assess the condition of the pavement microtexture as a result of winter maintenance brooming activities and wear on the pavement. Measurement and monitoring of pavement microtexture is important in order to get an understanding of the potential for hydroplaning on the runway, since good microtexture is the principal means of mitigating viscous hydroplaning (TSB, 2011).

A series of friction tests were also completed using the GripTester instrument (manufactured by Findlay Irvine Ltd. of Scotland) starting at station 5+200 and ending at station 6+600, at 1.5 m, 3 m, 5 m, 10 m and 15 m left and right offsets from the centreline, at varying water depths and rain intensities. The results are analyzed below and compared to the testing completed by Tradewind Scientific in 2011, 2007 and 2004. Contour maps showing the variations in existing pavement texture and friction based on 2013 testing results are attached in Appendix B.

5.1 Findings

Surveys of microtexture and macrotexture were completed on sections of the runway where extensive brooming as a result of winter maintenance occurs (0 to 10 m offsets from the centreline) as well as near the edges of the runway where less brooming passes occur (at 20 m offsets from the centreline). The purpose of this testing pattern was to compare the textures in these areas and determine microtexture and macrotexture increase/decrease as a result of winter maintenance activities.

5.1.1 Outflow Meter Testing

Based on the Outflow Meter test results, the highest macrotexture was generally found at 7 m left and right offsets, 10 m left and right offsets and along the centreline. The lowest macrotexture was found to be at 20 m left and right offsets, with slightly higher macrotexture at 3 m left and right offsets. The highest points of macrotexture occurred between stations 5+475 to 6+500.

Figure 5.1 shows the distribution of the 2013 Outflow Meter test results over the area of the runway. In addition, a contour map showing the distribution and ranges of macrotexture on the runway pavement surface from Outflow Meter testing is presented in Appendix B.

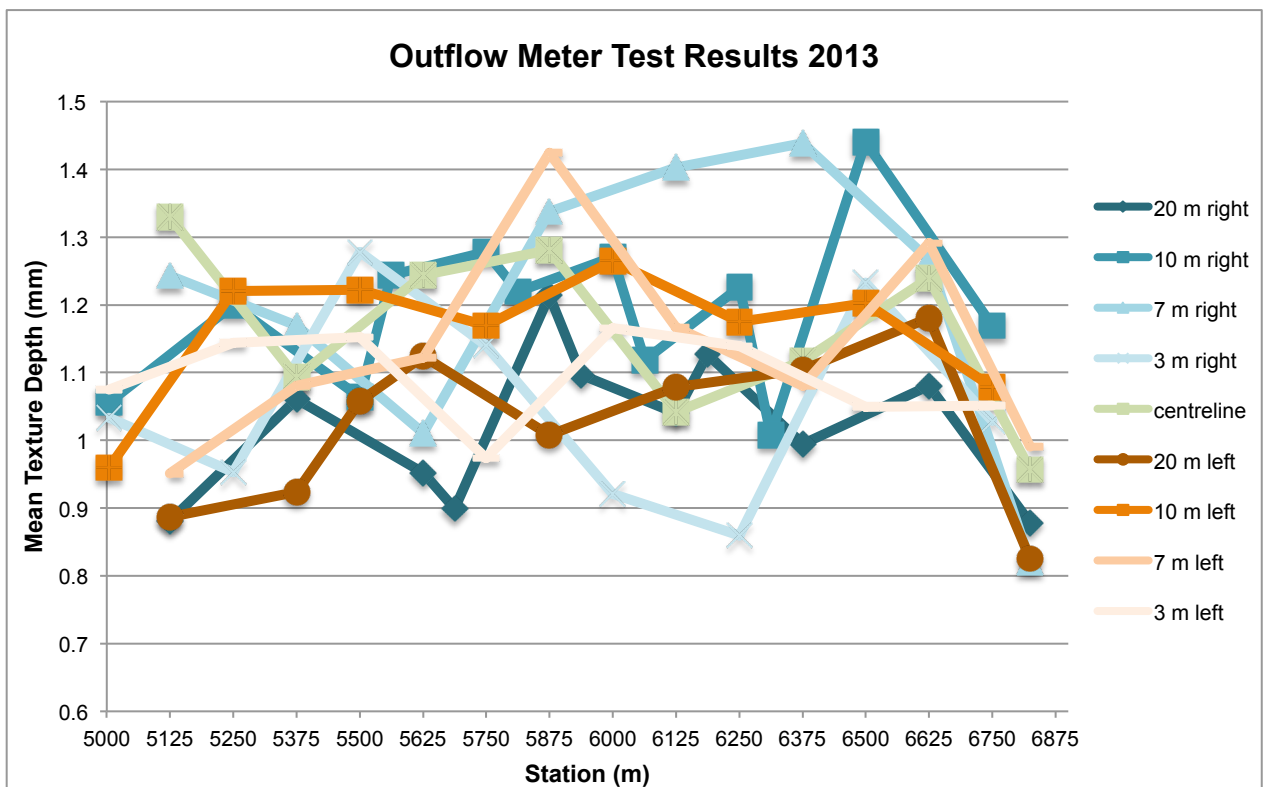

Figure 5.1 2013 Outflow Meter test results

As noted in Chapter 3, in the 2011 Tradewind Scientific evaluation a series of Outflow Meter tests were used to evaluate the macrotexture of the runway, at the centreline and at 5 m left and right offsets from the centreline. The results are presented in a graph (Figure 5.2 as well as Figure 3.3 in Chapter 3). The average Mean Texture Depth (MTD) at the 5 m left and right offsets from centreline was 1.1 mm and the average at the centreline was 1.2 mm (in 2011).

When comparing the results from 2011 and 2013, the centreline should be directly compared since the 5 m left and right offsets were tested in 2011 but not in 2013. The graph in Figure 3.4 shows how the MTD varies in 2011 vs. 2013 at the centreline, along the length of the runway. The average MTD in 2013 along the centreline is 1.2 mm (which is the same average MTD as 2011). The graph shows that along the middle portion of the runway between stations 5+400 and 6+700, the macrotexture was generally higher in 2011 than 2013. However, when averaged over the length of the runway, the 2011 and 2013 had the same average MTD of 1.2 mm. This shows that the balance of aircraft traffic (wear) and winter maintenance activities (brooming) results in a macrotexture that remained generally stable over the years. It should be noted that rubber contamination may be affecting (decreasing) the measured macrotexture values.

Analysis of previous testing data from 2004 and 2007 (as shown on Figures 3.4 and 3.5) show that macrotexture actually has increased over the years, likely due to excessive winter maintenance activities. Outflow Meter test data from 2004 and 2007 can be compared with 2013 Outflow Meter testing data since tests in all three years were completed along the same offsets (3 m left and right of centreline). It should be noted that Outflow Meter testing was not completed in 2011 at the 3 m left and right offsets and thus is not included in the comparison. Figures 5.4 and 5.5 show a comparison between the 2004, 2007 and 2013 Outflow Meter macrotexture results at 3 m offsets. From these graphs, it is evident that macrotexture has increased from 2007 to 2013 at both left and right offsets from the centreline. The average macrotexture increased by about 0.1 mm (on average by 12 percent) from 2004 to 2007 and from 2007 to 2013.

Federal Aviation Administration (FAA) guidelines state that when the average texture depth measurement in a runway zone (i.e. touchdown, midpoint and rollout) falls below 1.14 mm, the airport operator should conduct texture depth measurements each time a runway friction survey is completed. When the average texture depth falls below 0.76 mm but remains above 0.4 mm, the airport operator should initiate plans to correct the pavement texture deficiency within a year. When the average texture depth falls below 0.25 mm, the airport operator should correct the pavement texture deficiency within 2 months (Federal Aviation Administration [FAA], 1997).

When compared to the above mentioned FAA guidelines, the macrotexture on Runway 07-25 measured in 2013 is above the requirements for action and thus macrotexture improvements at this point are not necessary.

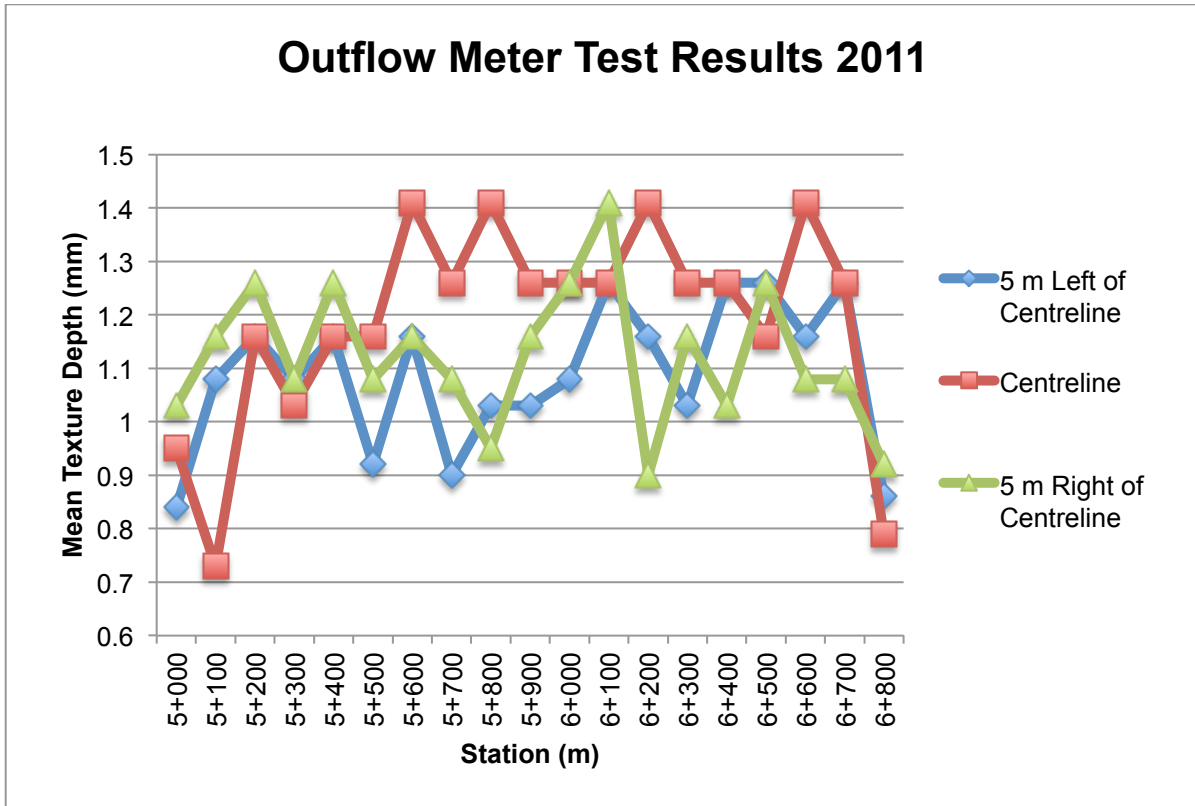

Figure 5.2 2011 Outflow Meter test results

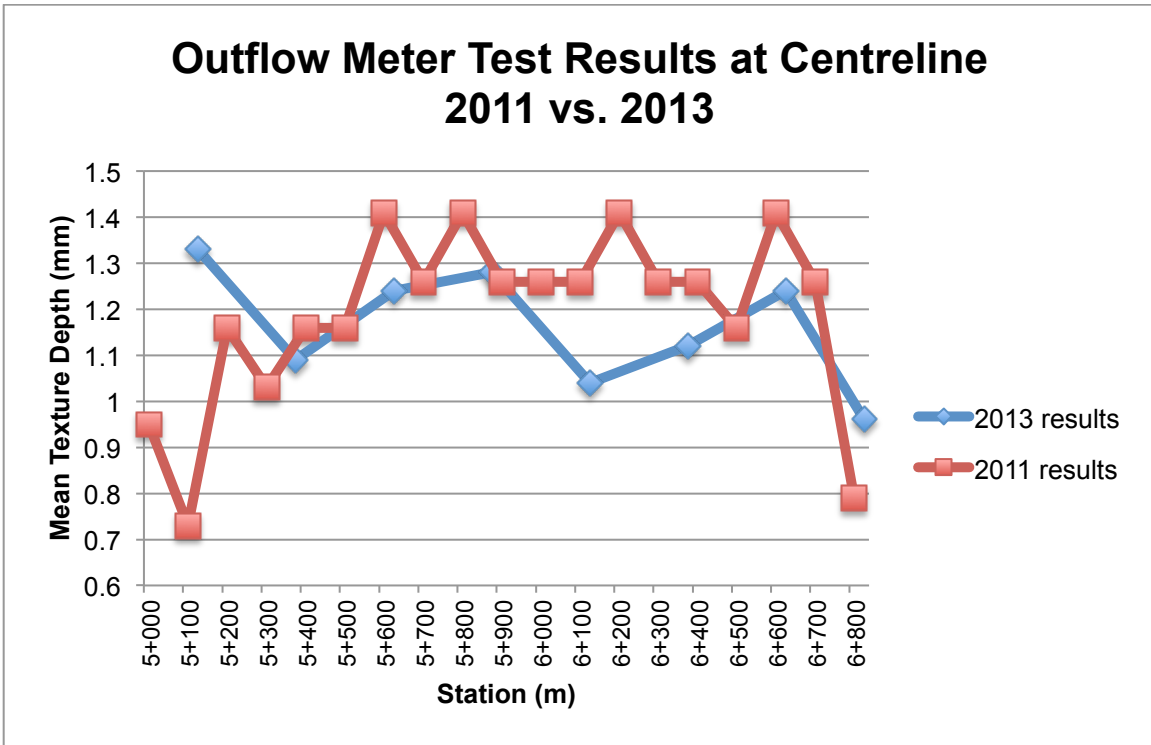

Figure 5.3 2011 vs. 2013 Outflow Meter test results at centreline

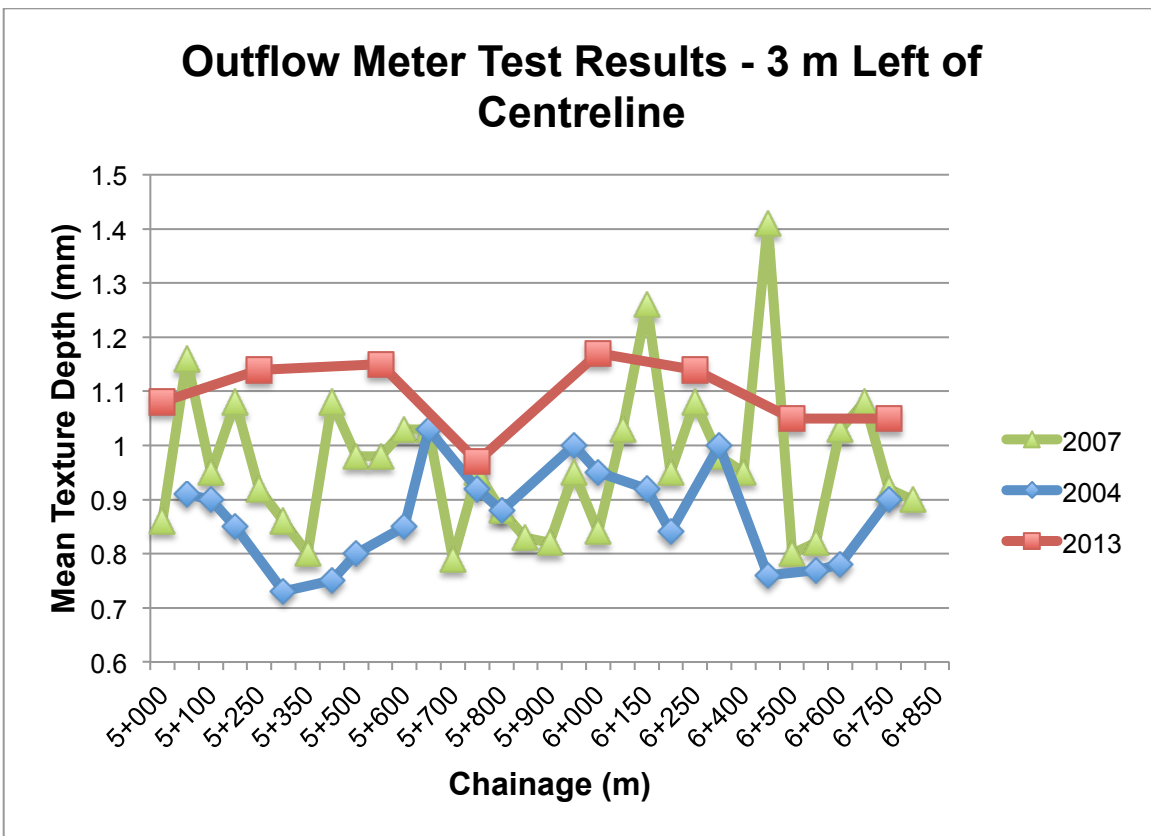

Figure 5.4 Outflow Meter test results at 3 m left of centreline at various years

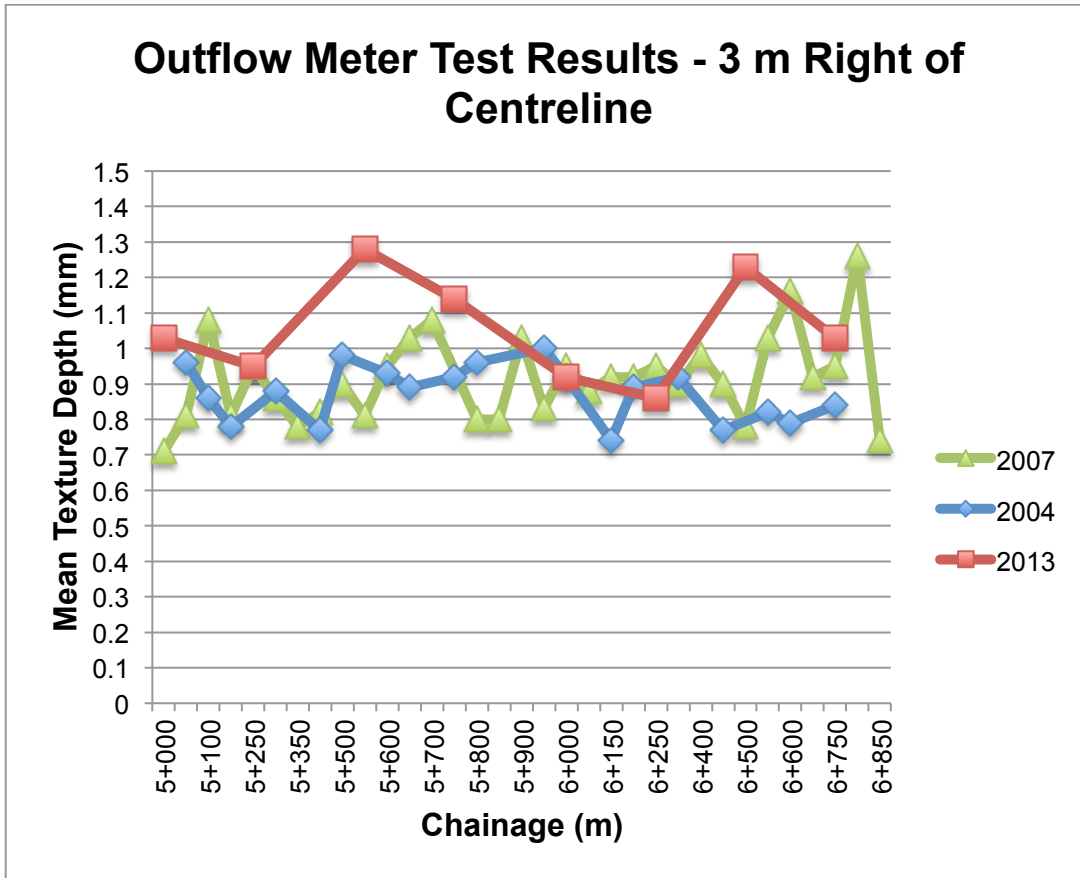

Figure 5.5 Outflow Meter test results at 3 m right of centreline at various years

5.1.2 Sand Patch Testing

Similar to the results of the Outflow Meter testing, the Sand Patch testing showed the highest macrotexture to be at 7 m left and right offsets, 10 m left and right offsets and along the centreline. The lowest macrotexture was found to be at 20 m left and right offsets, with slightly higher macrotexture at 3 m left and right offsets. The highest points of macrotexture occurred between stations 5+500 to 6+750.

Figure 5.6 shows the distribution of Sand Patch test results over the area of the runway. In addition, a contour map showing the distribution and ranges of macrotexture on the runway pavement surface from Sand Patch testing is presented in Appendix B.

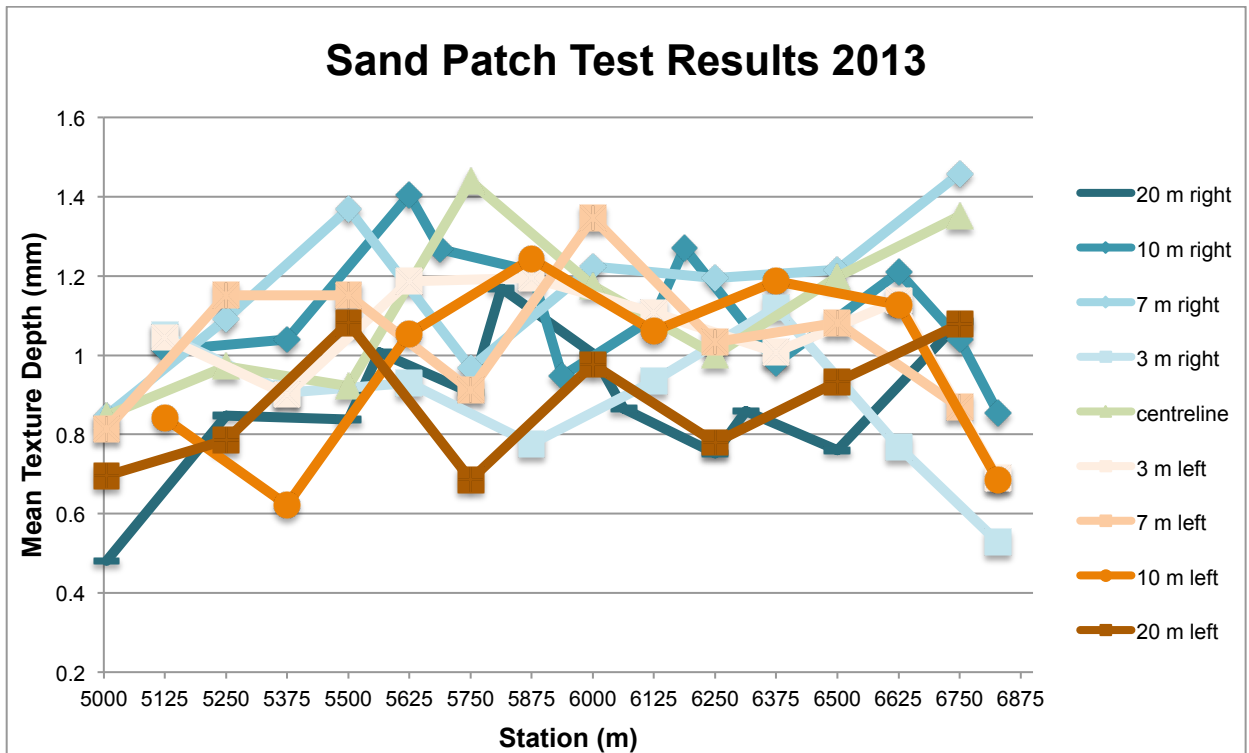

Figure 5.6 Sand Patch test results

Table 5.1 shows a summary and comparison of the Mean Texture Depths (MTD) obtained by Outflow Meter and Sand Patch testing in 2013. There does not appear to be a direct correlation between the results of the two tests, however the Sand Patch results appear to be generally lower (by approximately 0.1 mm). The results show that the lowest MTD was found at 20 and 3 m offsets from the centreline, with the highest MTD at 7 and 10 m offsets from the centreline and along the centreline.

These results appear to be reasonable. The macrotexture is likely lower at 3 m left and right offsets from the centreline due to the fact that the majority of aircrafts are landing on this runway along these lines due to their wheel spans. This results in traffic wear on the pavement which decreases macrotexture and rubber from the aircraft tires being deposited on these areas of the runway, especially concentrated in the touchdown zones. Rubber deposits will result in reduced macrotexture since rubber fills the voids between the aggregate particles and asphalt binder. Traffic wear reduces macrotexture since the aggregates get worn down, decreasing the depth of voids between the asphalt binder and top of aggregate.

A cause for the lower macrotexture at 20 m left and right offsets from the runway centreline may be due to fewer winter maintenance brooming passes occurring in those areas of the runway. Brooming increases the pavement macrotexture as the aggressive sweeping of the steel bristles deteriorates the asphalt binder which in turn exposes the

aggregates more. The voids between the top of aggregate and bottom of asphalt binder are thus increased. The highly durable aggregates used in the asphalt mix are not worn down by the brooming as rapidly as the softer asphalt binder.

Table 5.1 Summary of mean texture depths

Location Offset (m)	Outflow Meter Test		Sand Patch Test	
	Mean Texture Depth (mm)	Rank	Mean Texture Depth (mm)	Rank
20 m right	1.02	1	0.92	2
20 m left	1.02	1	0.88	1
10 m right	1.19	5	1.11	7
10 m left	1.18	4	0.98	4
7 m right	1.20	6	1.13	8
7 m left	1.18	4	1.05	6
3 m right	1.08	2	0.93	3
3 m left	1.12	3	1.03	5
centreline	1.19	5	1.11	7

The highest macrotexture was observed at 7 and 10 m offsets from the centreline, as well as along the centreline. This is likely due to the extensive brooming occurring in these areas of the runway, in conjunction with lower amounts of rubber deposits and traffic wear of the pavement. The majority of aircraft landing at Kuujjuaq runway do not have wheel spans large enough to cover these areas of 7 and 10 m offsets. Also, there is less traffic wear and rubber deposit along the centreline, resulting in higher macrotexture.

5.1.3 British Pendulum Testing

British Pendulum test results are reported as British Pendulum Number (BPN), which is related to the pavement microtexture. The highest BPN (highest microtexture) was found at 20 and 7 m left and right offsets, middle ranges were at 10 and 3 m offsets and lowest microtexture was found at the centreline. The microtexture differences between 20, 10, 7 and 3 m offsets were very small. The highest points of microtexture occurred between stations 5+500 to 6+375, in the middle portion of the length of the runway. The overall average BPN is 73.4.

Figure 5.7 shows the distribution of British Pendulum test results over the area of the runway. In addition, a contour map showing the distribution and ranges of microtexture on the runway pavement surface in terms of BPN is presented in Appendix B. Table 5.2 shows a summary of BPN numbers for the various lines of testing.

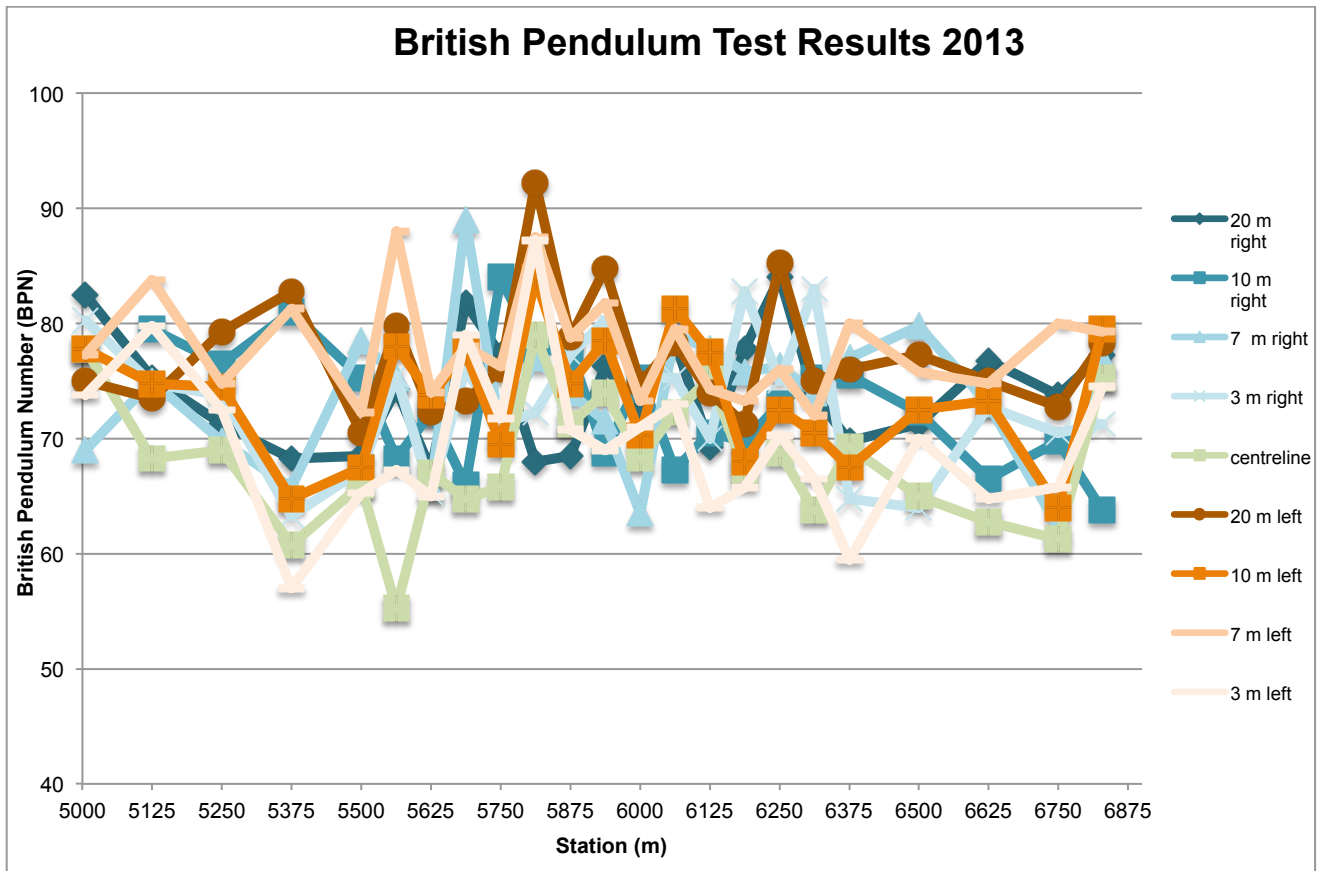

Figure 5.7 British Pendulum test results

Table 5.2 Summary of British Pendulum test results

Location Offset (m)	Mean British Pendulum Number (BPN)
20 m right	74
20 m left	77
10 m right	73
10 m left	74
7 m right	74
7 m left	78
3 m right	73
3 m left	70
centreline	68

The microtexture is highest at 20 m left and right offsets from the centreline. This is due to the fact that the least amount of brooming passes occur at this offset. Brooming as a result of winter maintenance decreases microtexture as the steel broom bristles polish the

surface aggregates in the asphalt, and the rate of aggregate polishing is directly related to the size, weight and volume of aircraft on the runway. In addition, the least amount of aircraft wheel passes occur at this offset, and aircraft traffic also polishes aggregates in the asphalt resulting in decreased microtexture.

A cause for the lowest microtexture along the centreline of the runway may be due to the highest amount of brooming passes/overlap of brooming passes and resulting polished aggregate occurring along the centreline.

The rubber deposits at portions of the runway where the wheels of aircraft touchdown most frequently can be a cause of the low microtexture in these areas. Additionally, more brooming passes occur at areas where wheels traverse the runway which also results in lower microtexture.

At 3 m left and right offsets from the centreline, traffic wear is highest and resulting microtexture is relatively low as compared to other areas of the runway.

5.1.4 Friction Testing

In September 2013, a series of friction tests were completed by LVM using the GripTester instrument (manufactured by Findlay Irvine Ltd. of Scotland) between stations 5+200 and 6+600 along the runway. Testing was completed as per current standard test specifications for the GripTester equipment (ASTM E2340 *Standard Test Method for Measuring the Skid Resistance of Pavements and Other Trafficked Surfaces Using a Continuous Reading, Fixed-Slip Technique*); testing speed of 65 km/h using a smooth-tread ASTM test tire at 140 kPa inflation pressure, under self-watering conditions of 0.25 mm water film depth, at 3 m left and right offsets from the centerline. Additional tests were completed at 1.5 m, 5 m, 10 m and 15 m left and right offsets from the centreline, at varying water depths (0.25 mm, 0.5 mm and 1.0 mm) and rain intensities (light and moderate rain) for additional analyses of the runway surface. Prior to testing, the GripTester was calibrated in order to verify the specifications and ensure optimal performance. A photograph of the testing is shown in Figure 5.8.



Figure 5.8 2013 GripTester operations (Field Testing, 2013)

Complete results of the testing are presented on graphs in Appendix A. The average GripTester Friction Number is plotted as a function of runway chainage. The first graphs show the runway friction profiles for the testing at standard conditions (0.25 mm water depth at 3 m left and right offsets from the centerline) and the remaining test results are presented on the subsequent graphs.

In addition to the 2013 testing results, graphs are also presented for the 2011 testing which was completed by Tradewind Scientific, at the same offsets and water depths for comparison.

Generally, the 2013 test results show consistent friction profiles along the length of the runway, with minimum friction values in the touchdown zones for test runs in the wheel paths (1.5 m to 5 m left and right offset from centerline). The typical touchdown zones on the runway range from about station 5+250 to 5+600 on the 07 end of the runway and station 6+500 to 6+250 on the 25 end.

Table 5.3 presents a summary and comparison of GripTester results from 2011 and 2013. Where possible, the percent reduction of friction values between the two years was calculated and shown in the far right column.

Table 5.3 Summary of GripTester results from 2013 and 2011

Offset from Centreline	Water Depth/Rain Intensity	Average GripTester Friction Number 2013	Average GripTester Friction Number 2011	Reduction between 2011 and 2013
3 m L&R	0.25 mm	64	68	5.9 %
1.5 m L&R	0.25 mm	64	67	4.5 %
5 m L&R	0.25 mm	63	68	7.4 %
10 m L&R	0.25 mm	66	71	7.0 %
15 m L&R	0.25 mm	64	77	16.9 %
3 m L&R	0.5 mm	64	Not completed	-
1.5 m L&R	0.5 mm	63	Not completed	-
5 m L&R	0.5 mm	60	Not completed	-
10 m L&R	0.5 mm	64	Not completed	-
15 m L&R	0.5 mm	66	Not completed	-
3 m L&R	1.0 mm	60	66	9.1 %
1.5 m L&R	1.0 mm	58	66	12.1 %
5 m L&R	1.0 mm	61	65	6.2 %
10 m L&R	1.0 mm	62	75	17.3 %
15 m L&R	1.0 mm	61	71	14.1 %
3 m L&R	Light Rain	Not completed	72	-
1.5 m L&R	Light Rain	Not completed	71	-
5 m L&R	Light Rain	Not completed	68	-
10 m L&R	Light Rain	63	75	16 %
15 m L&R	Light Rain	Not completed	77	-
3 m L&R	Moderate Rain	62	62	0 %
1.5 m L&R	Moderate Rain	58	62	6.5 %
5 m L&R	Moderate Rain	54	59	8.5 %
10 m L&R	Moderate Rain	Not completed	66	-
15 m L&R	Moderate Rain	59	69	14.5 %

For testing at standard conditions (3 m left and right offsets with 0.25 mm water depth), the average GripTester Friction number in 2013 is 64. The results from 2011 showed an average GripTester Friction number of 68; a reduction of about 6% in the two years. The 2013 result remains above the Transport Canada Maintenance Planning Average Runway Level of 60. It should also be noted that the average GripTester Friction number from 2007 and 2004 under the same conditions was 70 and 78 respectively (as shown in Table 5.5), which indicates a general declining trend for runway friction.

For the remainder of the tests, the average GripTester Friction numbers are generally above 60 (the Transport Canada Maintenance Planning Average Runway Level), except

for 1.5 m left and right offset at 1.0 mm water film depth, and 1.5 m, 5 m and 15 m left and right offsets in moderate rain, which vary between 54 and 59.

The lowest friction values were observed in the wheel paths, 1.5 to 5 m away from the centreline. As water film depths increased or rain intensity increased, friction values decreased as expected. The lowest friction values measured were generally under moderate rain intensity.

The large percent reductions noted in the far right column of Table 5.3 (14.1 to 17.3 percent) are likely due to the GripTester traversing over paint marks on the runway during the 2013 testing. The paint marks were generally encountered by the GripTester equipment at 10 and 15 m left and right offsets from the centreline where the touchdown zone and aiming point markings exist. The painted surface is smoother than the actual runway pavement, which resulted in lower friction values in those areas. It would be expected that the friction values were higher at 10 and 15 m offsets since these offsets have a lower amount of aircraft traffic.

At locations containing rubber deposits on the runway, generally from 1.5 to 5 m offsets from the centreline in the touchdown areas at both ends, recorded friction values were lower, as reflected on the graphs presented in Appendix A. Graphs showing 2011 testing results are also presented in Appendix A, for comparison. Table 5.4 shows locations on the runway under various test conditions where the GripTester Friction Number recorded was below the Transport Canada Maintenance Planning Average Level of 60. However, it should be noted that no test results fell below the minimum 100 m Maintenance Planning Level of 40.

The 2013 friction testing results indicate that the majority of tests (and all tests at standard test conditions) are above the acceptable Transport Canada guidelines, even in the touchdown zones where the runway experiences most traffic wear and rubber contamination (resulting in reduced microtexture and macrotexture). In these areas of high aircraft traffic, winter maintenance brooming is most aggressive and the balance of the two result in acceptable friction values. Winter maintenance results in increased macrotexture resulting in improved friction in wet conditions. However, an excessive amount of winter maintenance (brooming) in future years may lead to excessively high macrotexture with resulting aggregate popout, which leads to a loss of friction. Notwithstanding, a declining trend has been observed in friction measurements over the years, and further testing should be completed in the future to continue monitoring friction levels.

Table 5.4 2013 100 m Minimum GripTester results below 60

Offset from Centreline	Water Depth/Rain Intensity	Location near 07 end (Station)	100 m GripTester Friction Number	Location near 25 end (Station)	100 m GripTester Friction Number
3 m L&R	0.25 mm	5+300 to 5+500	57-59	-	-
15 m L&R	0.25 mm	5+400	58	6+500	53
3 m L&R	0.5 mm	5+500	59	6+400	58
1.5 m L&R	0.5 mm	-	-	6+000, 6+400	59
5 m L&R	0.5 mm	5+400	58	6+000 to 6+200	58-59
10 m L&R	0.5 mm	5+500	59	-	-
3 m L&R	1.0 mm	5+300 to 5+500	52-59	-	-
1.5 m L&R	1.0 mm	5+300 to 5+700	51-59	6+000 to 6+600	58-59
5 m L&R	1.0 mm	5+400	54	6+000, 6+200	59
10 m L&R	1.0 mm	5+400	56	6+500	54
15 m L&R	1.0 mm	5+300 to 5+500	53-59	-	-
10 m L&R	Light Rain	5+400 to 5+500	55-58	6+200	59
3 m L&R	Moderate Rain	5+300 to 5+500	51-56	-	-
1.5 m L&R	Moderate Rain	5+300 to 5+600	49-59	6+000, 6+200 to 6+600	56-59
5 m L&R	Moderate Rain	Whole length of runway (5+300 to 6+600)			44-57
15 m L&R	Moderate Rain	5+300 to 5+500	49-58	6+500	53

Table 5.5 shows a comparison between the GripTester Friction measurements from 2004, 2007, 2011 and 2013.

Table 5.5 Comparison of GripTester results from 2004 to 2013

YEAR:		2004*		2007*		2011**		2013**	
Offset from Centreline (L&R)	Water Depth/Rain Intensity	Avg. Grip No.	100 m Min. Grip No.	Avg. Grip No.	100 m Min. Grip No.	Avg. Grip No.	100 m Min. Grip No.	Avg. Grip No.	100 m Min. Grip No.
3 m	0.25 mm	78	71	70	74	68	62	64	57
13*/15** m	0.25 mm	88	86	74	68	77	69	64	53
3 m	0.5 mm	76	68	72	60	-	-	64	58
13*/15** m	0.5 mm	79	75	74	68	-	-	66	61
3 m	1.0 mm	67	60	67	58	66	60	60	52
3 m	Light rain	-	-	58	42	72	65	-	-
3 m	Moderate rain	-	-	59	48	62	54	62	51
13*/15** m	Moderate rain	-	-	60	52	69	65	59	49

For testing at standard conditions (3 m left and right offsets and 0.25 mm water film depth), a declining trend has been observed for the average GripTester friction number as shown in Table 5.5: 78 in 2004, 70 in 2007, 68 in 2011, and 64 in 2013. With a relatively low water film depth, a noticeable decrease in friction has occurred over the years. This shows that microtexture loss is occurring on the runway as microtexture affects surface friction in relatively dry/slightly wet conditions. Microtexture is decreased by winter maintenance activities and aircraft traffic.

For an evaluation of macrotexture loss, friction values under moderate rain intensity may be compared as wet pavement friction is affected by macrotexture. For instance, the second last row in Table 5.5 shows that the average GripTester friction results for 3 m left and right offsets have been relatively stable from 2007 to present: 59 in 2007, 62 in 2011 and 62 in 2013. This shows that macrotexture loss is not really occurring. These results make sense as aggressive brooming occurs for snow/ice control at the 3 m left and right offset resulting in increased macrotexture. The balance of aircraft traffic wear and brooming operations result in stable macrotexture values.

Comparing the last row of Table 5.5, at the 13/15 m offsets from centreline, surface friction is decreasing over the years: 69 in 2011 and 59 in 2013 (the value of 60 in 2007 does not really make sense and perhaps is a testing error). Less brooming passes occur at the 15 m left and right offsets which means macrotexture is not increasing as a result, and decreasing over time due to environmental wear. As macrotexture decreases, friction decreases.

Contour maps showing the differences in existing pavement friction on the surface of the runway were developed based on the 2013 testing results for 0.25, 0.5 and 1.0 mm water depths, and presented in Appendix B. These contour maps show how the friction characteristics of the pavement vary over the surface of the runway, based the various offsets tested. In general, friction is lower along the centreline, and is higher away from the centreline. Certain areas show significantly lower friction values (for example near station 5+600 at 10 m offsets from the centreline) however as mentioned above this is likely due to the equipment traversing paint marks resulting in inaccurately low friction values.

The lower friction values along the centreline and closest to the centreline correspond with the lowest microtexture values found in these same areas of the runway. As the water depths increase, the surface friction decreases over the area of the runway.

Figures 5.9 to 5.11 show various graphical representations of the 2013 friction testing data. Figure 5.12 shows a graphical comparison between the 2013 and 2011 data at standard test conditions. A full set of graphs containing all of the friction measurements from 2013 and 2011 are included in Appendix A. As previously noted, on all of the graphs the Transport Canada guidelines are shown in green, yellow and red, as per Table 3.1.

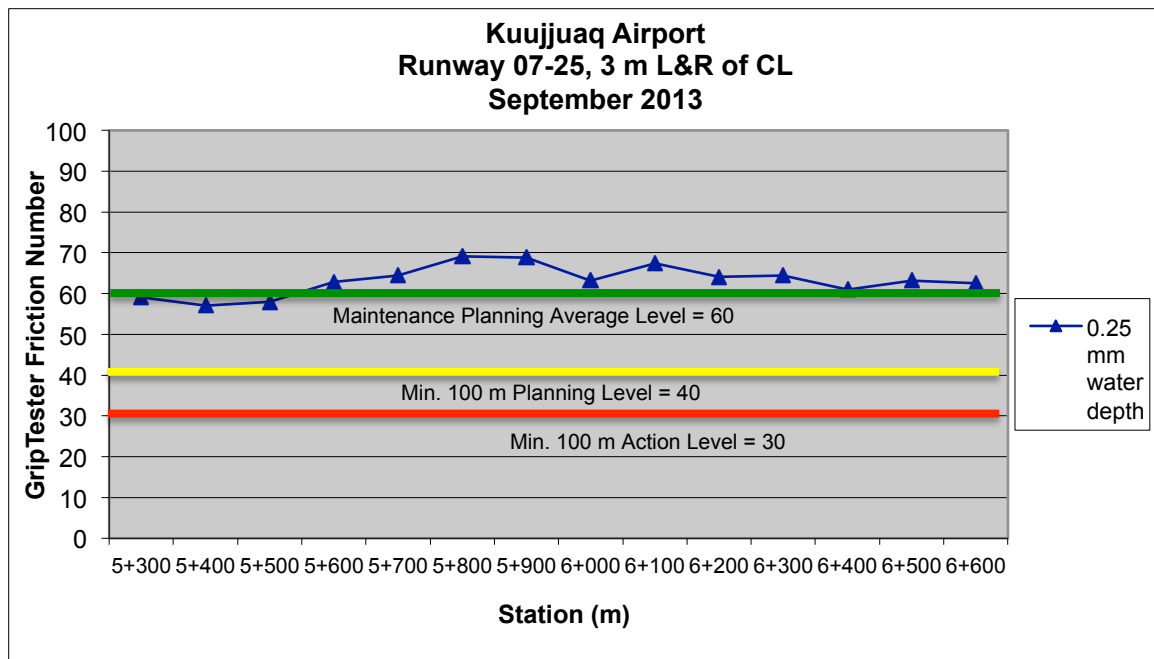

Figure 5.9 Friction testing results at standard test conditions

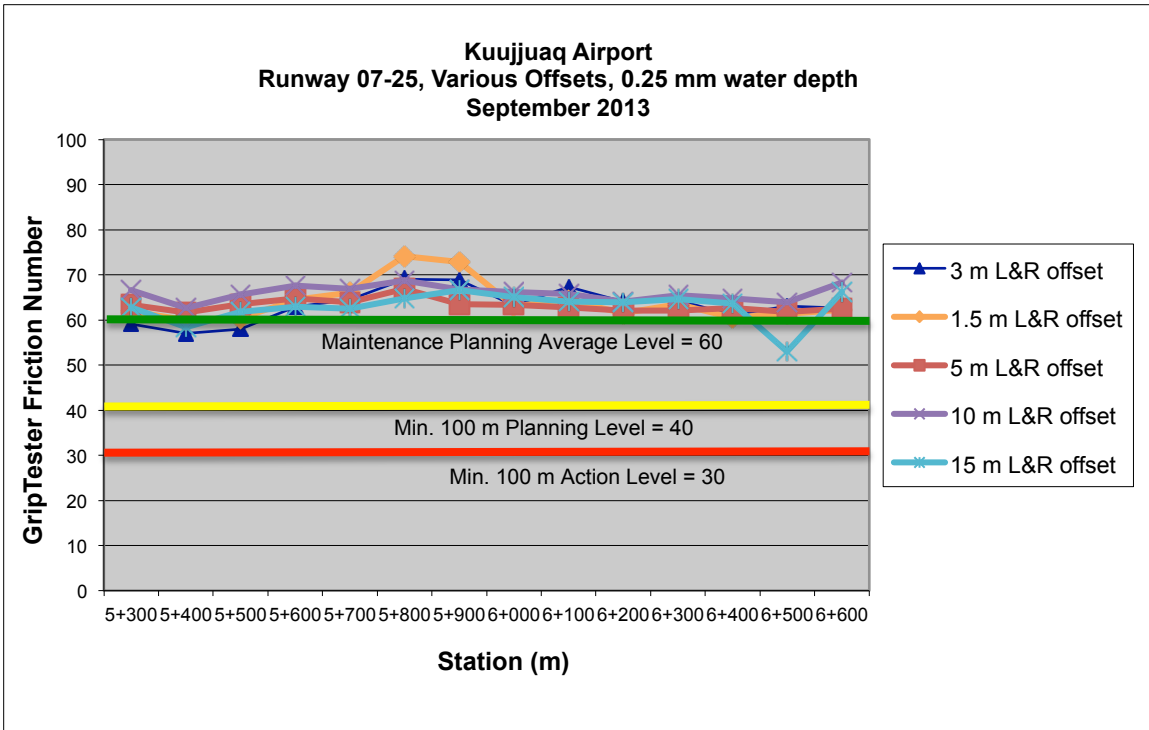

Figure 5.10 Friction testing results at various offsets from centreline and 0.25 mm water depth

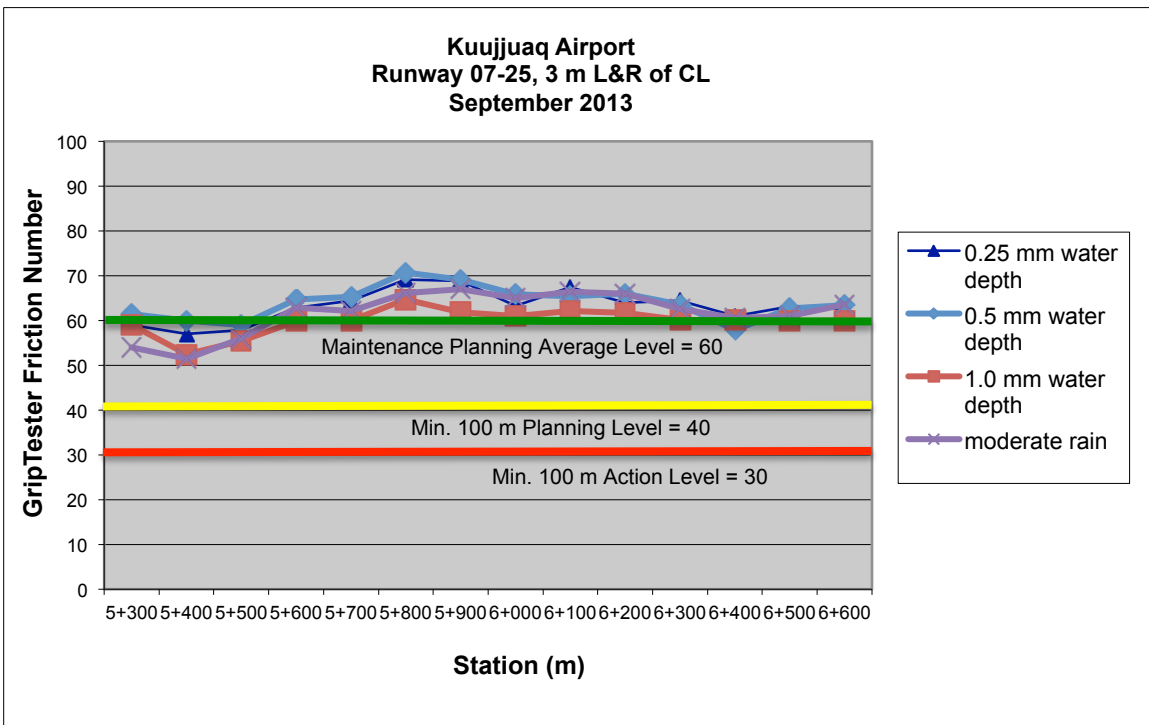

Figure 5.11 Friction testing results at 3 m left and right offsets from centreline and at various water depths/rain intensity

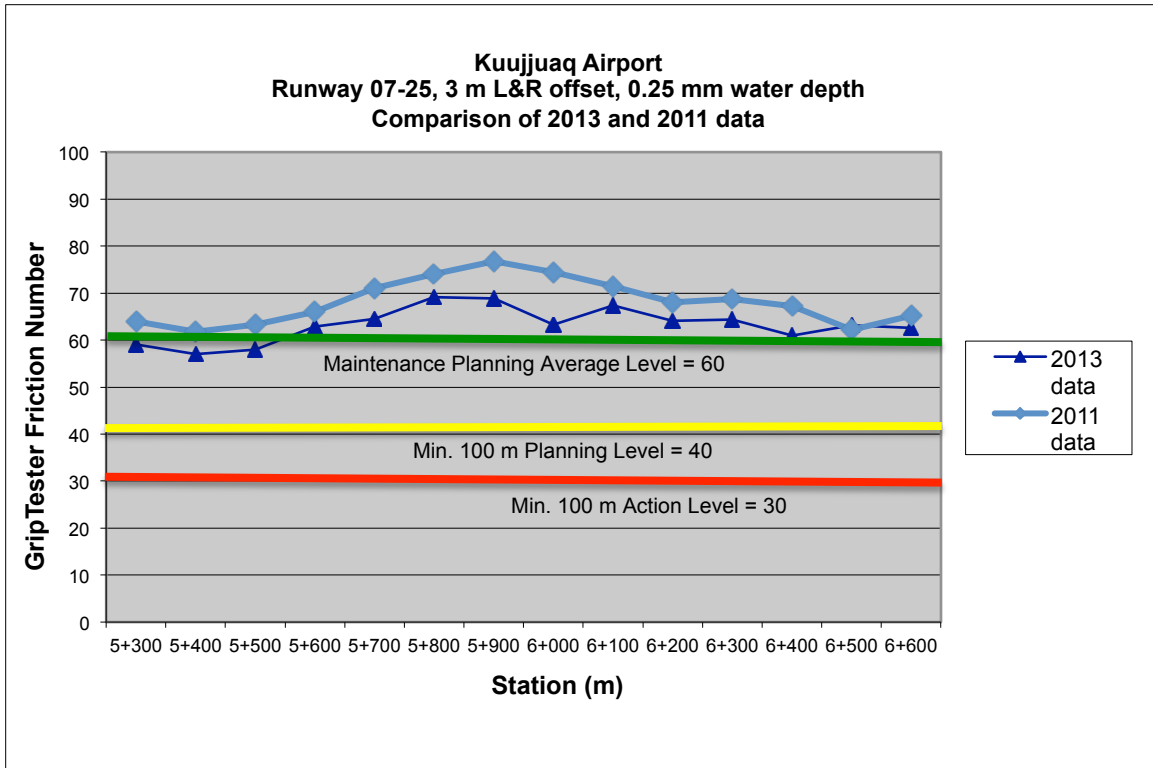

Figure 5.12 Friction testing results at standard test conditions from 2011 and 2013

5.1.4.1 Predicting Future Performance

Relevant data collected to date has been used to develop a regression equation, which may be used to predict future performance of the runway in terms of its frictional resistance.

It should be noted that limited data was available in developing the regression equation. In order to develop a sound regression equation to predict future performance based on historical data, various historical points should be used; the more data points available, the better the model will predict future performance. In order to use the largest amount of data possible, test results from 2004, 2007, 2011 and 2013 were used where testing was completed at identical offsets and water depths. Table 5.5 provides a summary of data with testing completed under the same conditions in multiple years, however not all testing scenarios in this table have tests from all four years (2004, 2007, 2011 and 2013). The three testing scenarios which contain full data sets from all four years are 3 m left and right offsets from centreline at 0.25 mm and 1.0 mm water depths, and 13/15 m left and right offsets at 0.25 mm water depth. It should be noted that the testing results at 13/15 m left and right offsets were not used in developing a model since the amount of aircraft wheel passes are low at these offsets of the runway.

Figure 5.13 shows a graph displaying the results for testing at 3 m left and right offsets from centreline, at 0.25 mm and 1.0 mm water depths. The blue line (0.25 mm water depth) shows a general declining trend, however the red line (1.0 mm water depth) shows results that are not changing from 2004 to 2011. At 1.0 mm water depth, the average friction number was 67 in 2004, 67 in 2007 and 66 in 2011. Since this test was completed at the same offset as the 0.25 mm water depth test (same pavement surface and texture) these stable results show that friction is not changing from year to year at a higher water depth. This shows that the pavement macrotexture is either increasing or staying relatively stable, as the microtexture of the pavement is known to be decreasing due to high aircraft traffic volumes traversing these offsets of the runway and aggressive winter maintenance activities (brooming). With the decrease in microtexture, and increase in macrotexture, the pavement friction remains stable at a higher water depth as friction in wet conditions is mainly influenced by macrotexture.

Although the friction test at 1.0 mm water depth gives a good indication of the past and current condition of pavement macrotexture, the test results are not useful in developing a future friction performance prediction model due to the stability of the values and lack of declining trend over time. It should also be noted that continuing macrotexture increases in future years (due to aggressive brooming) may eventually lead to raveling of the pavement surface (loss of bond between aggregate particles and asphalt binder, resulting in loss of aggregate) due to mechanical wear of asphalt binder, and this would result in reduced friction in wet pavement conditions. A prediction model based on historical performance could not adequately predict in this situation, since raveling of the pavement surface has generally not occurred.

Thus, to develop a future performance prediction model, useful data which are available are only the test results at 3 m left and right offsets at 0.25 mm water depth (blue line on Figure 5.13). Using these data, multiple regression equations were developed and the optimal model was chosen based on an analysis of the coefficient of determination and the most reasonable future predicted results for the runway.

The two chosen regression equations to analyze further were logarithmic and linear. The logarithmic regression equation had a coefficient of determination (R^2) value of 0.96 and the linear regression had an R^2 value of 0.91. Although the logarithmic equation has a higher R^2 value, the predicted results in future years (as shown by the green line on Figure 5.14) did not make sense. The logarithmic prediction curve shows that the rate of deterioration slows with increasing years, and in 10 years from now the Friction Number would still be above 60. This is not likely as with continuing traffic wear and winter maintenance, friction will likely eventually experience a large decrease due to aggregate loss and the logarithmic model does not accurately predict this.

The linear regression equation does not fit the historical data as well as the logarithmic function, but the predicted future friction values are more reasonable. It is therefore at this time recommended that a linear regression be used if future performance prediction is required, as described by the equation below.

$$y = -1.395x + 78.02$$

where x represents number of years from 2004; for example, x=1 at 2004, x=2 at 2005, x=3 at 2006, etc.

This linear regression model for past and future years is graphically shown in Figure 5.14 (purple line). Based on this linear regression model, it would appear that in 2016, the Average Friction Number would be 60, and in 2017 it would fall below 60 to 58. At this point, the Transport Canada Guideline would be reached (Friction Number of 60 corresponds to maintenance planning). This may be confirmed by friction testing which should be carried out in 2015. It would be expected that runway maintenance planning activities be undertaken in 2016 and executed within the year in order to improve the runway friction to a level greater than 60. Friction testing by GripTester is recommended to be carried out every 2 years until 2017 at which point friction would be expected to be increased if maintenance/rehabilitation is completed; and friction testing could be carried out at less frequent intervals thereafter, provided that the friction restoring activities improved the friction to a desirable level. Various methods of friction restoration are discussed in chapter 6.

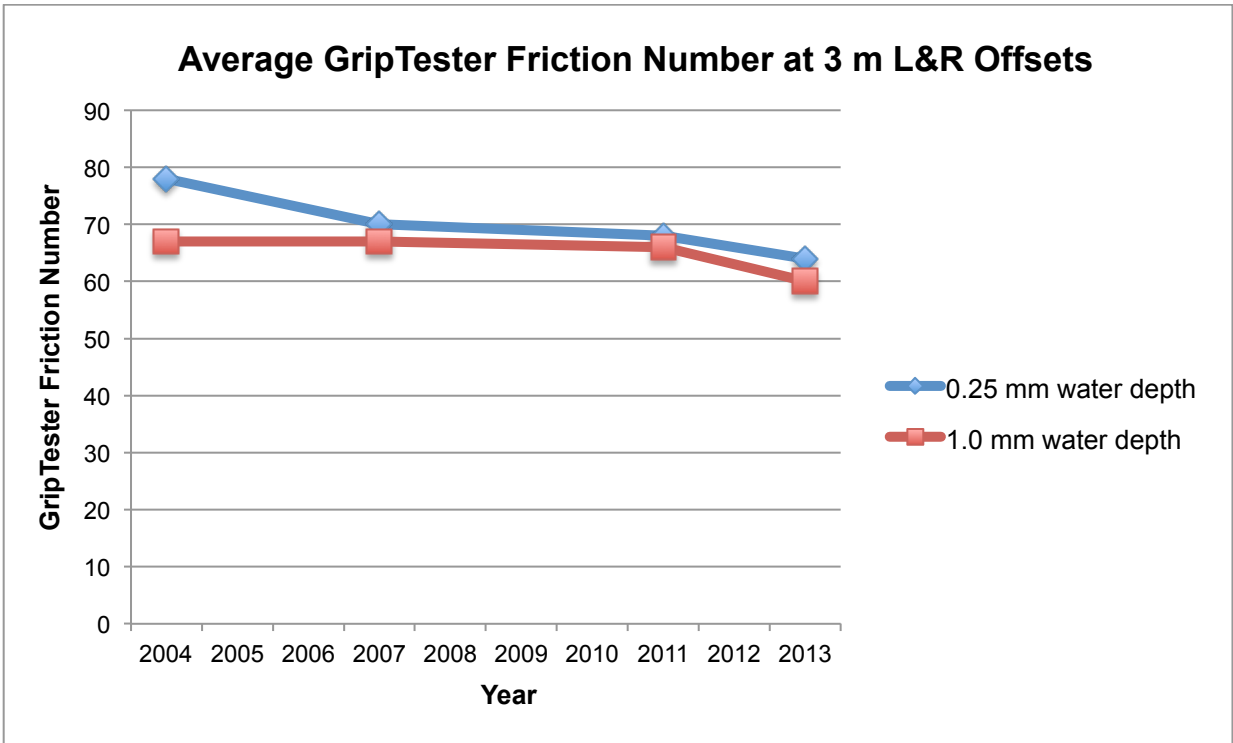

Figure 5.13 Friction testing results from multiple years

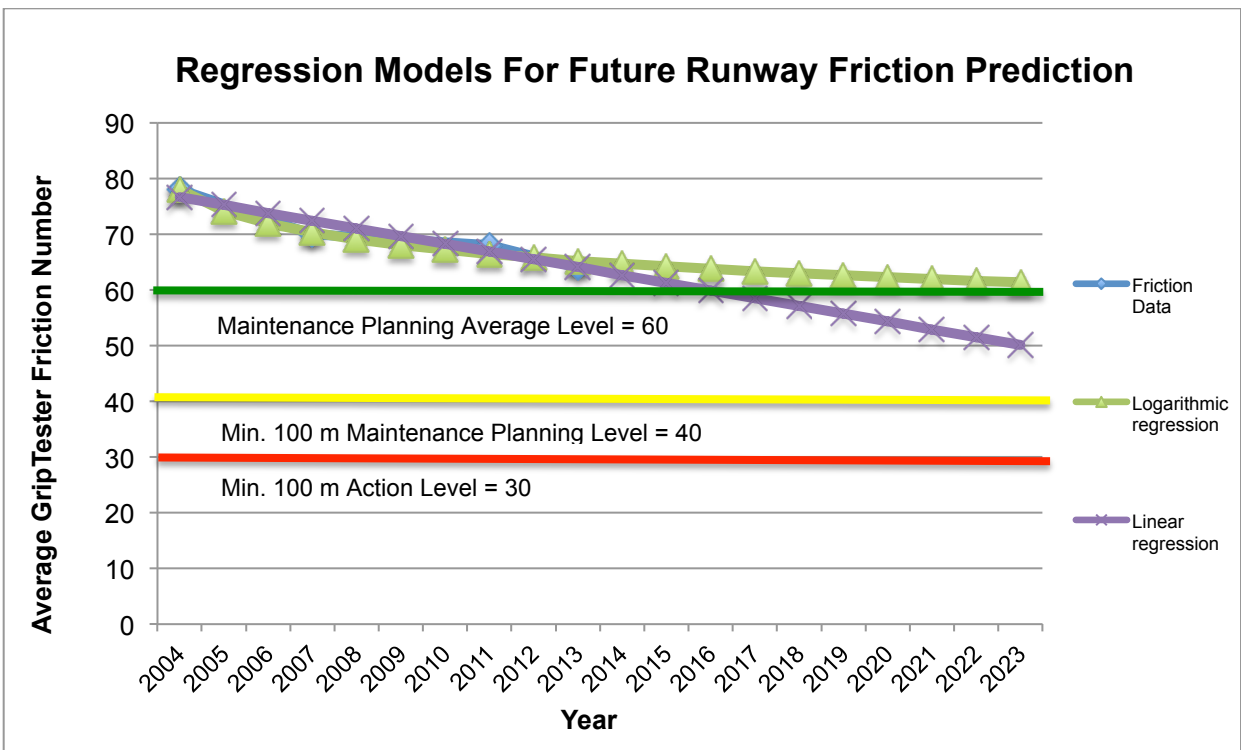

Figure 5.14 Regression models

5.1.5 Coring Investigation

A coring investigation was completed at the same time as the surface texture and friction testing program in the fall of 2013. Various cores of the asphalt concrete were obtained using a 150 mm diameter core barrel equipped with diamond drill bit along the length of the runway at various offsets from the centreline. Figures 5.15 and 5.16 show photographs of two core samples. The cores were obtained for visual examination only as it was not possible to complete laboratory testing.

The asphalt concrete was observed to be in good condition based on the visual examination of the cores. Additionally, the aggregate in the asphalt mix appeared to be crushed and durable. Based on a site inspection of the surrounding areas of the runway, it was evident that this locally sourced aggregate observed in the asphalt concrete was also used on a gravel service roadway, where the gravel appeared to be durable and in very good condition.



Figure 5.15 Core 1, 3 m left of centreline at station 5+250 m



Figure 5.16 Core 2, 10 m left of centreline at station 5+375 m

5.2 Chapter Summary

Field testing was completed in August and September of 2013 on Runway 07-25 of Kuujjuaq Airport. The types of tests completed were Sand Patch and Outflow Meter for macrotexture, British Pendulum for microtexture and GripTester for surface friction. In addition, core samples were obtained from multiple locations on Kuujjuaq runway for visual examination.

The highest macrotexture occurs in areas with the highest frequency of aggressive brooming and lower amount of aircraft traffic (7 and 10 m offsets from centreline and along the centreline). The intensive brooming increases macrotexture while aircraft wear decreases macrotexture. Hence at 3 m left and right offsets (high frequency of brooming and large amounts of aircraft traffic) the macrotexture is lower than the 7 and 10 m offsets as the wear from the traffic reduces the macrotexture. The macrotexture at 20 m is lower since brooming passes are less frequent at these offsets.

The average mean texture depth in 2013 was 1.2 mm along the centreline of the runway, which is higher than the FAA guidelines for runways requiring macrotexture improvements. In 2011, the average MTD was also 1.2 mm, which shows that the balance of pavement wear from aircraft traffic and winter maintenance activities (brooming) result in a macrotexture that remains generally stable. Previous macrotexture

testing data from 2004 and 2007 show that macrotexture has actually increased over the years. Comparing 2013 data with 2004 and 2007 data, it is evident that macrotexture increased (by 24% from 2004 to 2013), likely due to aggressive brooming on the runway.

The highest BPN (highest microtexture) was observed to be at 20 and 7 m left and right offsets, middle ranges were at 10 and 3 m offsets and lowest microtexture was found at the centreline. The microtexture differences between 20, 10, 7 and 3 m offsets were very small. The overall average BPN is 73.4.

Microtexture is highest at 20 m left and right offsets from the centreline due to the fact that the least amount of brooming passes occur at this offset. Brooming as a result of winter maintenance decreases microtexture as the steel broom bristles polish the surface aggregates in the asphalt, and the rate of aggregate polishing is directly related to the size, weight and volume of aircraft on the runway. In addition, fewer aircraft have wheel passes at this offset, and aircraft traffic also polishes aggregates in the asphalt resulting in decreased microtexture. At 3 m left and right offsets from the centreline, traffic wear is highest and resulting microtexture is relatively low as compared to other areas of the runway (rubber contamination in these areas also results in lower microtexture measurements). In addition, the lowest microtexture along the centreline of the runway may be due to the highest amount of brooming passes/overlap of brooming passes and resulting polished aggregate occurring along the centreline.

The results of the friction testing show consistent friction profiles along the length of the runway, with minimum friction values in the touchdown zones for test runs in the wheel paths (1.5 m to 5 m left and right offset from centerline). As water film depths increased or rain intensity increased, friction values decreased as expected. The lowest friction values measured were generally under moderate rain intensity.

For testing at standard conditions (3 m left and right offsets with 0.25 mm water depth), the average GripTester Friction number in 2013 is 64. The results from 2011 showed an average GripTester Friction number of 68; a reduction of about 6% in the two years. The 2013 result remains above the Transport Canada Maintenance Planning Average Runway Level of 60. It should also be noted that the average GripTester Friction number from 2007 and 2004 under the same conditions was 70 and 78 respectively, which indicates a general declining trend for runway friction.

For the remainder of the tests, the average GripTester Friction numbers are generally above 60 (the Transport Canada Maintenance Planning Average Runway Level), except for 1.5 m left and right offset at 1.0 mm water film depth, and 1.5 m, 5 m and 15 m left and right offsets in moderate rain, which vary between 54 and 59.

Based on the linear regression model developed for future prediction of runway performance in terms of surface friction, it would appear that in 2016, the Average

Friction Number would be 60, and in 2017 it would fall below 60 to 58. At this point, the Transport Canada Guideline for maintenance planning would be reached. It would be expected that runway maintenance planning activities be undertaken in 2016 and executed within the year in order to improve the runway friction to a level greater than 60.

Based on a visual examination of the cores obtained from Runway 07-25, the asphalt concrete was observed to be in good condition. The aggregates in the asphalt mix appeared to be crushed and durable. Based on a site inspection of the surrounding areas of the runway, it was evident that this locally sourced aggregate observed in the asphalt concrete was also used on a gravel service roadway, where the gravel appeared to be durable and in very good condition.

Chapter 6

Friction Improvement Technologies for Kuujuaq Runway 07-25

As part of this study, different options for improving the pavement surface friction on Runway 07-25 are explored, with a general overview of each technology described in this chapter. As stated above, these options aim to mitigate the impacts of climate change on the pavement surface friction characteristics. The four following technologies/products considered herein could be applicable to either maintenance, improvement of the actual runway or future rehabilitation works. They consist of runway grooving, shotblasting, slurry seal and a hot mix asphalt overlay using the ESG-10 mix.

6.1 Runway Grooving

Runway grooving consists of constructing parallel transverse channels (grooves) in the pavement surface, which improve the macrotexture, reduce water-film thicknesses during rainfall and provide an escape channel for water that may become trapped between the pavement surface and aircraft tire. These effects reduce the potential for aircraft hydroplaning under wet conditions. Grooving may improve aircraft braking performance on a wet runway as compared to a wet non-grooved runway (Transport Canada, 2012).

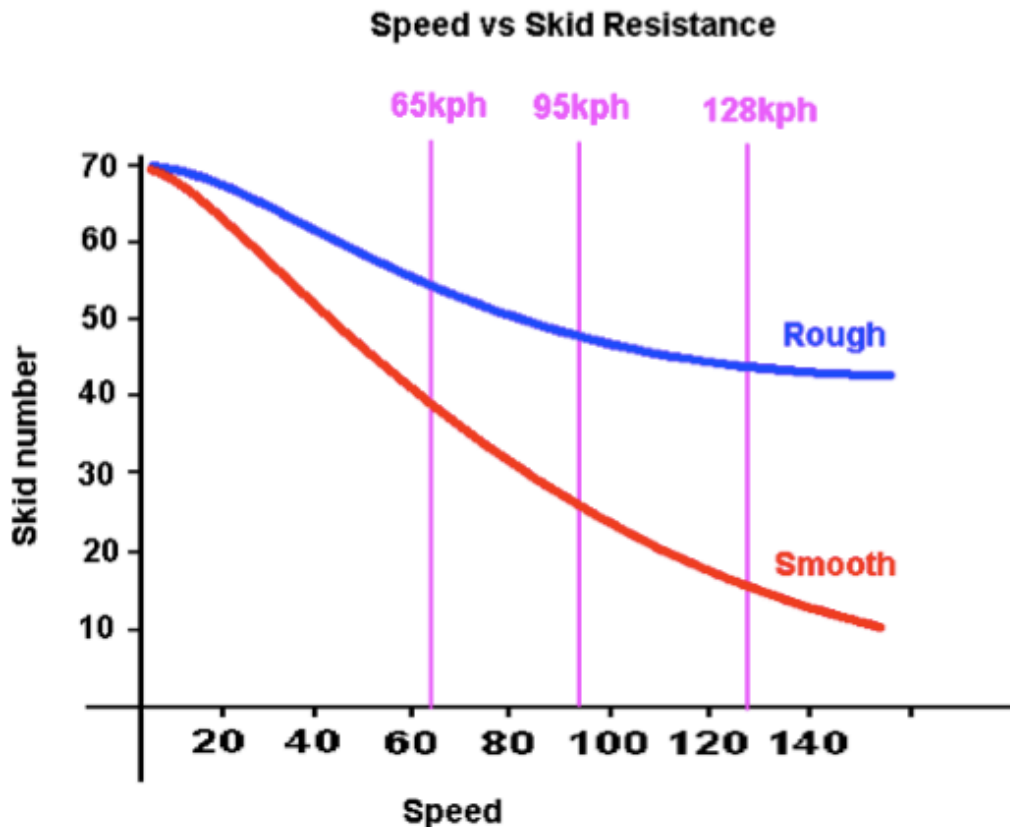

Figure 6.1 Effect of grooves on macrotexture (ICAO, 2012)

As the speed of aircraft increases, the friction between the tire and the pavement surface decreases as shown in Figure 6.1. Grooving adds macrotexture to the surface and offsets this effect, as indicated by the gap between the rough and smooth traces (ICAO, 2012).

Runway grooving is typically considered when the presence of excessive water depths exist on the surface of a pavement which may create the potential for hydroplaning; however, it is not a requirement for new or existing runway pavements in Canada (Transport Canada, 2012).

Hydroplaning is a complex phenomenon which depends on several variables such as water film thickness, aircraft speed, tire pressure, tire tread condition and the microtexture and macrotexture properties of the pavement surface. During hydroplaning, the aircraft tire rides on the water film and skid resistance is virtually eliminated (Transport Canada, 2012).

Runway grooving will not prevent the accumulation of water due to ruts and ponding. Surface drainage is achieved by the provision of suitable runway transverse slopes and by minimizing surface depressions, which may result in the accumulation of standing water. Runway grooving helps to reduce water film depths during rainfall but does have limits with respect to coping with deep standing water due to heavy rainfall (Transport Canada, 2012).

In order to determine whether there is a need for runway grooving on a particular runway, the following should be considered (Transport Canada, 2012).

- A historical review of aircraft accidents/incidents related to hydroplaning on the runway;
- Wetness frequency (annual rainfall);
- Transverse and longitudinal slopes, flat areas, depressions, mounds or any other surface abnormalities that may impede water runoff;
- Surface texture quality, which if not sufficient, may contribute to slipperiness under dry or wet conditions. For example, polishing of aggregate, improper seal coating, inadequate microtexture or macrotexture and contaminant build up that reduces surface texture; and
- Crosswind effects, particularly when low friction factors prevail at the airport.

In addition, it should be determined whether the existing pavement surface is suitable for grooving, by considering the following (Transport Canada, 2012).

- The existing pavement surface may not be suitable for grooving. A condition of the runway should be conducted to determine if an overlay or permanent rehabilitation is required prior to grooving.

- A thorough inspection should be conducted to evaluate the structural condition and integrity of the pavement. If areas exist with extensive cracking or spalling, or with bumps, depressions or significant ruts, grooving is not recommended unless such areas are adequately repaired or replaced.
- For hot-mix asphalt (HMA) pavements, the stability of the asphalt mix should be considered in evaluating the suitability of the pavement for grooving. Other factors to be considered in determining how long grooves will remain effective in HMA pavements are aggregate properties, maximum operational pavement temperature, effective tire pressure and frequency of braking action in given areas.

Recently, runway grooving was completed at Norman Wells Airport in the Northwest Territories, due to increasing incidents of B737 aircraft hydroplaning on the runway. The runway was paved in 2006; the asphalt mix contained a high fines content in the aggregate and a high asphalt binder content. The paver left ruts along the wheel path, and incidents of hydroplaning aircraft began to occur from 2007 to 2011. In 2011, runway grooving was completed (Northwest Territories Transportation, 2012).

The results of the grooving study showed that friction was improved after grooving, and no hydroplaning incidents have occurred since. The friction index was 0.05 to 0.08 higher where grooved, no chemicals were required during winter, ice came off the surface more easily on the grooved areas, the runway dried more rapidly after wet snow and slush, sweeping during and after rainstorms was no longer required and the airport received favorable feedback from the airlines (Northwest Territories Transportation, 2012).

In the study, it was recommended that grooving should be done the same year or the year following resurfacing of the runway. Also, the grooves should be monitored during warmer weather to see if any damage is done to the grooves by turning aircraft (Northwest Territories Transportation, 2012).

6.1.1 Advantages of Grooving

Advantages of grooving include improvement of pavement macrotexture, reduction in water-film thicknesses during rainfall and provision of an escape channel for water that may become trapped between the pavement surface and aircraft tire. These effects reduce the potential for aircraft hydroplaning under wet conditions. Grooving may improve aircraft braking performance on a wet runway as compared to a wet non-grooved runway. Grooving may assist in draining melted water and preventing refreezing. In addition, grooves will trap anti-icing chemicals, reducing loss of the chemicals and prolonging their actions. It is important to ensure that applied anti-icing/de-icing chemicals penetrate the grooves to prevent the formation of ice in the grooves (Transport Canada, 2012).

6.1.2 Disadvantages of Grooving

Runway grooving does not improve runway surface friction characteristics under winter ice and snow conditions. Ice or snow in the grooves may actually result in lower overall pavement friction values (Transport Canada, 2012). In addition, removal of ice from the grooves is a more difficult procedure than removing ice from a non-grooved surface.

A possible disadvantage of a grooved runway could occur if there are large temperature variations throughout the day. As a result, frost/ice may melt during the day, moisture will accumulate in the grooves and will likely freeze during the night. As these freeze-thaw cycles continue over time, the cracks and pores in the asphalt will expand from the ice expansion, weakening the runway surface under traffic loading, causing potential potholes to form.

6.2 Shotblasting

Shotblasting is a method used to restore pavement surface texture (both microtexture and macrotexture) on pavements that have a loss of skid resistance due to polishing of aggregate. Used extensively by airport pavement maintenance managers, the technology uses a machine that propels an abrasive particle onto the runway surface, which blasts away contaminants such as excess bitumen while restoring microtexture and macrotexture, in turn improving surface friction (Gransberg, 2009).

There are generally two types of shotblasting equipment. One is a vehicle mounted, self-contained unit with the apparatus that propels the abrasive particles as well as the magnetic vacuum system that picks up and separates the abrasive particles residue and dust, and stores it in a container for disposal. The cutting widths of this type of configuration are 1.8 m and a smaller version of 1.2 m. The other type consists of a smaller, ground mounted version that can cut 15-51 cm per pass. It can be mounted on a vehicle in a configuration where two shotblasters can be located over the wheel paths of a road to shotblast only the polished portions of the road, resulting in a higher rate of production. Each configuration generally has the following components: self-propelling apparatus, vacuum system, magnetic separator, residue container and follow-on magnetic brush and broom which picks up debris which might have been left by the shotblasting system (Gransberg, 2009).

6.2.1 Advantages of Shotblasting

In addition to being a technically and economically feasible option, the advantages of shotblasting include the environmentally sustainable nature of the technology. The surface texture is restored without the use of additional asphalt binder or aggregate. Thus, it is also immune to the volatility in asphalt prices, and is an attractive alternative in locations where high-quality aggregate is scarce (Gransberg, 2009). Additionally, the

equipment can be removed from the runway quickly if the runway is required to accommodate an emergency landing (Pinto, 2012). Rubber contamination is also removed from the runway surface when using this technology.

6.2.2 Disadvantages of Shotblasting

The major disadvantage of shotblasting includes the risk of foreign object debris (FOD) by a steel ball implanting into the pavement during the blasting process. FOD is a major concern for airport operators and managers (Pinto, 2012). In addition, the transportation of the equipment to the airport may be problematic.

6.3 Slurry Seal

Slurry seal is a highly durable, low cost, thin maintenance treatment consisting of a mixture of aggregate, asphalt emulsion, and filler, which are mixed together according to a laboratory's design-mix formula. Water is also added for workability. The slurry mixture is made quickly and accurately at the project site. Mixing and spreading are accomplished in one continuous operation, and the surface may be reopened to travel within a few hours (International Slurry Surfacing Association [ISSA], 2013). Microsurfacing and slurry seal are similar techniques which can achieve similar results, with the following differences. Microsurfacing has a higher polymer content in the emulsion, a higher asphalt residual content, fast setting chemicals which allow for a faster break and the use of higher quality aggregates.

The asphalt emulsion serves as a binder, holding the crushed aggregate together and adhering the new slurry surfacing to the old surface over which it is being applied. Various emulsions and aggregates are used to meet the conditions, specifications, and requirements of individual projects. Fillers such as Portland cement, hydrated lime, or aluminum sulfate liquid are often used in small quantities as stabilizers or chemical modifiers (ISSA, 2013).

The slurry is made in specially designed equipment, either truck-mounted or self-propelled. This equipment carries a quantity of unmixed materials which are blended together in a continuous flow pugmill. The use of this machinery ensures a smooth, consistently uniform mixture. The mixture is applied to an existing pavement surface by means of a spreader box linked to the surface slurry-mixing unit. The slurry is introduced into the spreader box, which then lays down the slurry coating as the mixer/spreader is driven forward (ISSA, 2013).

To achieve different types of slurry for varying purposes, emulsions of varying composition and setting times are mixed with any one of three grades of aggregates to create slurry seal mixes for specific purposes. The three aggregate types include Type I (fine), Type II (general), and Type III (coarse) (ISSA, 2013).

- Type I - Fine aggregate mixtures are used for maximum crack penetration and sealing in low-density/low-wear traffic areas.
- Type II – General aggregates are the most commonly used and are widely employed where moderate-to-heavy traffic is found. They seal, correct moderate-to-severe ravelling, oxidation and loss of matrix, and improve skid resistance.
- Type III – Coarse corrects severe surface conditions — preventing hydroplaning and providing skid resistance under very heavy traffic loads.

6.3.1 Advantages of Slurry Seal

The main advantages of using a slurry seal are the cost and speed. It is a relatively fast approach to resurfacing a pavement to attain increased frictional properties including increased microtexture and macrotexture. Aggregate and asphalt quantities are less and the equipment required to place the material is smaller and less complex than that required to place a hot mix asphalt overlay. In addition, the runway can be opened within a few hours after placement.

6.3.2 Disadvantages of Slurry Seal

A disadvantage of slurry seal is that it cannot be placed in extreme temperatures or during high humidity. Since asphalt emulsion contains water and asphalt binder, the emulsion must “break” (evaporation of water from the emulsion). Temperatures must allow the water to separate from the binder.

Slurry seals “can also remain tender for several weeks after placement, leaving marks or damage from turning vehicles. This can result in an FOD problem and require diligent sweeping operations during the early life of the slurry seal. Underlying cracks tend to reflect through the slurry seal in two to three years because the surface is very thin” (AAPTP, 2010).

In addition, slurry seals are recommended only as an interim measure until an overlay is constructed. They typically last for 2 to 5 years. Experience has shown that slurry seals do not hold up well in cold climates where snow removal occurs (FAA, 1997).

6.4 Overlay with Hot Mix Asphalt (ESG-10 Gyratory)

It has been recommended by Transport Canada that the possibility of constructing a hot mix asphalt (HMA) overlay using the MTQ ESG-10 mix on Runway 07-25 should be considered as a future rehabilitation strategy. ESG-10 is an asphalt mix used in Québec on national, regional and municipal roads (Uzarowski, Paradis & Lum, 2004). Tables 6.1 and 6.2 show mix and gradation properties of this asphalt mix. It should be noted that if the level of heavy traffic warrants, the rutting resistance is less than 20% at 3000 cycles on a 50 mm thick layer.

Table 6.1 Typical physical properties of ESG-10 mix (Québec Ministre des Transports, n.d.)

Properties	ESG-10 Mix Laboratory Results		
Asphalt Cement	5.0 – 5.4%	-	-
In place Compaction	93 - 95%	-	-
Air Voids	≥ 11% for 10 gyrations	4-7% for 80 gyrations	≥ 2% for 200 gyrations

Table 6.2 ESG-10 gradation requirements (Québec Ministre des Transports, n.d.)

Sieve size (mm)	Percent Passing	
	Minimum	Maximum
14	100	100
10	92	100
5	50	65
2.5	46.1	46.1
1.25	30.7	36.7
0.63	22.8	26.8
0.31	18.1	18.1
0.16	-	-
0.08	4	10

As an alternative, it is suggested that Transport Canada consider the use of Superpave for Canadian airfield mix designs for this runway. The good performance to date of the existing asphalt mix on the Kuujuaq runway can be attributed to the high percentage of asphalt cement in the mix, and this high percentage should be maintained for future mixes. In addition, the continuing increases of aircraft weights should be considered in the future mix designs to address the structural requirements and potential changes in climate.

6.4.1 Advantages of HMA Overlay

The advantages of a thin HMA overlay include a higher quality and longer lasting resurfacing option. Friction is restored as a new asphalt surface is placed, and this results in increases in both microtexture and macrotexture, and improved smoothness.

6.4.2 Disadvantages of HMA Overlay

The disadvantages of a thin HMA overlay include higher costs for equipment mobilization, materials and labour, and a longer runway closure duration.

6.5 Chapter Summary

In this chapter, different options for improving the pavement surface friction on Runway 07-25 are explored. The four following technologies/products considered herein could be applicable to either maintenance, improvement of the actual runway or future rehabilitation works. They consist of runway grooving, shotblasting, slurry seal and a hot mix asphalt overlay using the ESG-10 mix.

Runway grooving consists of constructing parallel transverse channels (grooves) in the pavement surface. Advantages of grooving include improvement of pavement macrotexture, reduction in water-film thicknesses during rainfall and provision of an escape channel for water that may become trapped between the pavement surface and aircraft tire. These effects reduce the potential for aircraft hydroplaning under wet conditions. Grooving may improve aircraft braking performance on a wet runway as compared to a wet non-grooved runway. Grooving may assist in draining melted water and preventing refreezing. In addition, grooves will trap anti-icing chemicals, reducing loss of the chemicals and prolonging their actions.

A disadvantage of a grooved runway could occur if there are large temperature variations throughout the day. As a result, frost/ice may melt during the day, moisture will accumulate in the grooves and will likely freeze during the night. As these freeze-thaw cycles continue over time, the cracks and pores in the asphalt will expand from the ice expansion, weakening the runway surface under traffic loading, causing potential potholes to form. Additionally, runway grooving does not improve runway surface friction characteristics under winter ice and snow conditions. Ice or snow in the grooves may actually result in lower overall pavement friction values. Removal of ice from the grooves is a more difficult procedure than removing ice from a non-grooved surface.

Shotblasting is a method used to restore pavement surface texture (both microtexture and macrotexture) on pavements that have a loss of skid resistance due to polishing of aggregate. The technology uses a machine that propels an abrasive particle onto the runway surface, which blasts away contaminants such as excess bitumen while restoring microtexture and macrotexture, in turn improving surface friction.

In addition to being a technically and economically feasible option, the advantages of shotblasting include the environmentally sustainable nature of the technology. The surface texture is restored without the use of additional asphalt binder or aggregate. Thus, it is also immune to the volatility in asphalt prices, and is an attractive alternative in

locations where high-quality aggregate is scarce. Additionally, the equipment can be removed from the runway quickly if the runway is required to accommodate an emergency landing. Rubber contamination is also removed from the runway surface when using this technology.

The major disadvantage of shotblasting includes the risk of foreign object debris (FOD) by a steel ball implanting into the pavement during the blasting process. FOD is a major concern for airport operators and managers (Pinto, 2012). In addition, the transportation of the equipment to the airport may be problematic.

Slurry seal is a highly durable, low cost, thin maintenance treatment consisting of a mixture of aggregate, asphalt emulsion, and filler, which are mixed together according to a laboratory's design-mix formula. The main advantages of using a slurry seal are the cost and speed. It is a relatively fast approach to resurfacing a pavement to attain increased frictional properties including increased microtexture and macrotexture. Aggregate and asphalt quantities are less and the equipment required to place the material is smaller and less complex than that required to place a hot mix asphalt overlay. In addition, the runway can be opened within a few hours after placement.

A disadvantage of slurry seal is that it cannot be placed in extreme temperatures or during high humidity. Since asphalt emulsion contains water and asphalt binder, the emulsion must “break” (evaporation of water from the emulsion). Temperatures must allow the water to separate from the binder. Slurry seals can also remain tender for several weeks after placement. In addition, slurry seals are recommended only as an interim measure until an overlay is constructed. They typically last for 2 to 5 years. Experience has shown that slurry seals do not hold up well in cold climates where snow removal occurs.

It has been recommended by Transport Canada that the possibility of constructing a hot mix asphalt (HMA) overlay using the MTQ ESG-10 mix on Runway 07-25 should be considered as a future rehabilitation strategy. ESG-10 is an asphalt mix used in Québec on national, regional and municipal roads. The advantages of a thin HMA overlay include a higher quality and longer lasting resurfacing option. Friction is restored as a new asphalt surface is placed, and this results in increases in both microtexture and macrotexture, and improved smoothness. The disadvantages include higher costs for equipment mobilization, materials and labour, and a longer runway closure duration.

Chapter 7

Conclusions and Recommendations

The purpose of this chapter is to provide a summary of various testing results completed in previous years and in 2013. In addition, recommendations are provided in this chapter in terms of maintenance/rehabilitation of Runway 07-25 to improve the long-term pavement friction characteristics.

7.1 Conclusions of Field Testing Results Completed in Previous Years

The following conclusions were made with respect to previous surface friction characteristics of the runway pavement. The Grip Numbers obtained in September 2011 by Tradewind Scientific using the GripTester show that the runway is in acceptable condition, generally exceeding the Transport Canada Maintenance Planning Runway Average Level guidelines (with low points in the touchdown zones while testing under moderate rain conditions). It also showed generally good surface texture depths as measured by the sand patch and outflow meter testing.

The results of the pavement condition survey completed in 2010 showed that the condition of the runway is fair with some localized poor areas. The most significant distresses are low to medium severity longitudinal and transverse cracking, low severity longitudinal cracking (construction joints), localized low to high severity depressions at cracks and few areas of low severity alligator cracking towards the 25 end of the runway.

The FWD testing results showed that the majority of the runway has medium (with localized high and low) pavement support characteristics. The impulse stiffness modulus of the pavement along the centerline of the runway was about 100-140 kN/mm, with some localized areas with higher values (140 to 200 kN/mm). The right edge of the runway (river side) showed lower modulus values of 50-80 kN/mm, likely due to the thawing of permafrost and poor drainage.

In addition, four types of friction restoration technologies/products were described including advantages and disadvantages of each: runway grooving, shotblasting, slurry seal and thin hot mix asphalt overlay using ESG-10.

7.2 Conclusions of 2013 Field Testing

Field testing was completed in August and September of 2013 on Runway 07-25 of Kuujjuaq Airport. The types of tests completed were Sand Patch and Outflow Meter for macrotexture, British Pendulum for microtexture and GripTester for surface friction. In addition, core samples were obtained from multiple locations on Kuujjuaq runway for visual examination.

The main objective of this field testing was to collect a complete set of current and relevant field data related to pavement surface texture and friction in order to complete analyses and gain an understanding of current runway conditions. The analyses were used to help in developing the options for improving the pavement surface friction on Runway 07-25 and to mitigate the impacts of climate change on the pavement surface friction characteristics.

7.2.1 Macrotexture Testing

Surveys of macrotexture (by means of Outflow Meter and Sand Patch) were completed on sections of the runway where extensive brooming as a result of winter maintenance occurs (0 to 10 m offsets from the centreline) as well as near the edges of the runway where less brooming passes occur (at 20 m offsets from the centreline). The purpose of this testing pattern was to compare the textures in these areas and determine macrotexture increase/decrease as a result of winter maintenance activities.

Based on the Outflow Meter test results, the highest macrotexture was generally found at 7 m left and right offsets, 10 m left and right offsets and along the centreline. The lowest macrotexture was found to be at 20 m left and right offsets, with slightly higher macrotexture at 3 m left and right offsets. The highest points of macrotexture occurred between stations 5+475 to 6+500.

The average mean texture depth in 2013 was 1.2 mm along the centreline of the runway, which is higher than the FAA guidelines for runways requiring macrotexture improvements. In 2011, the average MTD was also 1.2 mm, which shows that the balance of pavement wear from aircraft traffic and winter maintenance activities (brooming) result in a macrotexture that remains generally stable. Previous macrotexture testing data from 2004 and 2007 show that macrotexture has actually increased over the years. Comparing 2013 data with 2004 and 2007 data, it is evident that macrotexture increased (by 24% from 2004 to 2013), likely due to aggressive brooming on the runway.

Similar to the results of the Outflow Meter testing, the Sand Patch testing showed the highest macrotexture to be at 7 m left and right offsets, 10 m left and right offsets and along the centreline. The lowest macrotexture was found to be at 20 m left and right offsets, with slightly higher macrotexture at 3 m left and right offsets. The highest points of macrotexture occurred between stations 5+500 to 6+750.

There did not appear to be a direct correlation between the results of the Outflow Meter and Sand Patch testing, however the Sand Patch test results were generally lower (by about 0.1 mm on average).

The highest macrotexture occurs in areas with the highest frequency of aggressive brooming and lower amount of aircraft traffic (7 and 10 m offsets from centreline and

along the centreline). The intensive brooming increases macrotexture while aircraft wear decreases macrotexture. Hence at 3 m left and right offsets (high frequency of brooming and large amounts of aircraft traffic) the macrotexture is lower than the 7 and 10 m offsets as the wear from the traffic reduces the macrotexture. The macrotexture at 20 m is lower since brooming passes are less frequent at these offsets.

7.2.2 Microtexture Testing

Surveys of microtexture (by means of the British Pendulum test) were completed on sections of the runway where extensive brooming as a result of winter maintenance occurs (0 to 10 m offsets from the centreline) as well as near the edges of the runway where less brooming passes occur (at 20 m offsets from the centreline). The purpose of this testing pattern was to compare the microtexture in these areas and assess the general microtexture of the runway.

The highest BPN (highest microtexture) was observed to be at 20 and 7 m left and right offsets, middle ranges were at 10 and 3 m offsets and lowest microtexture was found at the centreline. The microtexture differences between 20, 10, 7 and 3 m offsets were very small. The highest points of microtexture occurred between stations 5+500 to 6+375, in the middle portion of the length of the runway. The overall average BPN is 73.4.

Microtexture is highest at 20 m left and right offsets from the centreline due to the fact that the least amount of brooming passes occur at this offset. Brooming as a result of winter maintenance decreases microtexture as the steel broom bristles polish the surface aggregates in the asphalt, and the rate of aggregate polishing is directly related to the size, weight and volume of aircraft on the runway. In addition, fewer aircraft have wheel passes at this offset, and aircraft traffic also polishes aggregates in the asphalt resulting in decreased microtexture. At 3 m left and right offsets from the centreline, traffic wear is highest and resulting microtexture is relatively low as compared to other areas of the runway (rubber contamination in these areas also results in lower microtexture measurements). In addition, the lowest microtexture along the centreline of the runway may be due to the highest amount of brooming passes/overlap of brooming passes and resulting polished aggregate occurring along the centreline.

7.2.3 Friction Testing

Friction testing was completed using the GripTester instrument between stations 5+200 and 6+600 along the runway. Testing was completed as per current standard test specifications for the GripTester equipment at a testing speed of 65 km/h using a smooth-tread ASTM test tire at 140 kPa inflation pressure, under self-watering conditions of 0.25 mm water film depth, at 3 m left and right offsets from the centerline. Additional tests were completed at 1.5 m, 5 m, 10 m and 15 m left and right offsets from the

centreline, at varying water depths (0.25 mm, 0.5 mm and 1.0 mm) and rain intensities (light and moderate rain) for additional analyses of the runway surface.

Generally, the 2013 test results show consistent friction profiles along the length of the runway, with minimum friction values in the touchdown zones for test runs in the wheel paths (1.5 m to 5 m left and right offset from centerline).

For testing at standard conditions (3 m left and right offsets with 0.25 mm water depth), the average GripTester Friction number in 2013 is 64. The results from 2011 showed an average GripTester Friction number of 68; a reduction of about 6% in the two years. The 2013 result remains above the Transport Canada Maintenance Planning Average Runway Level of 60. It should also be noted that the average GripTester Friction number from 2007 and 2004 under the same conditions was 70 and 78 respectively, which indicates a general declining trend for runway friction.

For the remainder of the tests, the average GripTester Friction numbers are generally above 60 (the Transport Canada Maintenance Planning Average Runway Level), except for 1.5 m left and right offset at 1.0 mm water film depth, and 1.5 m, 5 m and 15 m left and right offsets in moderate rain, which vary between 54 and 59.

The lowest friction values were observed in the wheel paths (1.5 to 5 m away from the centreline). As water film depths increased or rain intensity increased, friction values decreased as expected. The lowest friction values measured were generally under moderate rain intensity.

Based on the linear regression model developed for future prediction of runway performance in terms of surface friction, it would appear that in 2016, the Average Friction Number would be 60, and in 2017 it would fall below 60 to 58. At this point, the Transport Canada Guideline for maintenance planning would be reached. It would be expected that runway maintenance planning activities be undertaken in 2016 and executed within the year in order to improve the runway friction to a level greater than 60. Friction testing by GripTester is recommended to be carried out every 2 years until 2017 at which point friction would be expected to be increased if maintenance/rehabilitation is completed; and friction testing could be carried out at less frequent intervals thereafter, provided that the friction restoring activities improved the friction to a desirable level. Various methods of friction restoration are discussed in chapter 6.

7.3 Maintenance/Rehabilitation Recommendations

To restore surface friction on the runway surface, it is recommended that a sustainable rehabilitation option is used which will restore both the pavement microtexture and macrotexture. The friction restoring technologies presented in Chapter 6 have been

evaluated after the 2013 field testing analysis was completed and the following recommendations have been developed.

It is known that the pavement microtexture is decreasing as a result of traffic wear and winter maintenance (brooming), therefore, it is recommended that a friction restoration option is used which restores microtexture. Macrotexture loss is not currently a problem on Runway 07-25, however it may be in the future if aggressive brooming continues to occur which may lead to aggregate loss. Restoration/improvement of microtexture is critical on Runway 07-25 since good microtexture plays an important role in prevention of hydroplaning. The close proximity of the runway to a body of water (the Koksoak river) and existing runway crossfall creates an importance of hydroplaning mitigation as water (in the form of fog) is easily generated on the runway.

Microtexture testing has not been completed in previous years on Runway 07-25, only in the field testing program in 2013. It is recommended that microtexture testing continues in future years in order to monitor microtexture loss as a result of traffic wear and winter maintenance. As part of the friction testing program which is recommended to be carried out every 2 years, microtexture testing should be carried out in 2015 (along with the friction testing and macrotexture testing) to check for trends, and continue in future years.

Runway grooving and shotblasting (as discussed in Sections 6.1 and 6.2 respectively), are a good means of improving macrotexture. In addition, they are short term friction restoration options. Slurry seal (as discussed in Section 6.3) addresses both microtexture and macrotexture, however it is a short term friction restoration option (2-5 year service life) and does not perform well on runways with extensive snow/ice removal activities. Therefore, the most sustainable and long lasting friction and texture restoration method which addresses both microtexture and macrotexture is a hot-mix asphalt overlay. Section 6.4 describes a recommended mix used in Quebec (ESG-10) which would be beneficial for Kuujuaq airport. This mix has a high asphalt binder content which has shown to work well on Runway 07-25 to date.

The 2013 laboratory testing results presented in Chapter 4 show that the percentage of asphalt cement in the existing asphalt mix is 5.68. The mix design for the surface course on Runway 07-25 shows an asphalt cement content of 5.5 percent. This is a relatively high asphalt content percentage for typical asphalt mixes. The ESG-10 mix has an asphalt cement content of up to 5.4 percent.

For HMA pavements, the size and properties of the coarse aggregate are critical for good macrotexture. Generally, the larger size aggregates in HMA pavement mixtures provide greater skid-resistance than the smaller sizes. After size and gradation, the most frequently considered characteristics for skid-resistant aggregates are resistance to polish and wear, texture, and shape of particles (FAA, 1997).

The presence of coarse grain sizes and large differences in grain hardness appear to combine and lead to differential wear and breaking off of grains. This results in a constantly renewed abrasive surface. Aggregates with high silica content are thought to be the best performers. Generally, high carbonate rocks are poor performers. Rocks that are generally acceptable are unweathered crushed quartzite, quartz diorite, granodiorite, and granite (FAA, 1997).

The surface textures of individual aggregates are governed by the size of the individual mineral grains and the matrix in which they are cemented. For aggregates to exhibit good skid-resistant properties, they should contain at least two mineral constituents of different hardness cemented in a matrix that will wear at differing rates, which will continually expose new surfaces (FAA, 1997).

The shape of an aggregate (determined by crushing), significantly affects its skid-resistant properties. The higher the angularity of an aggregate, the better the skid-resistant quality. Flat and/or elongated particles have shown to be poor performers (FAA, 1997).

In order to mitigate the effects of climate change on the runway friction characteristics, it is paramount that the selected aggregates for the surface course asphalt mix are of the highest quality (in terms of resistance to polishing and wear, texture and shape of particles) in order to maintain microtexture and macrotexture throughout the aggressive winter maintenance activities which are expected to occur in the future.

Provided they meet the above mentioned characteristics in terms of resistance to polishing and wear and texture, local aggregates (similar aggregates used in existing mix) may be used in the new mix as they have shown to be durable and based on the visual examination of the cores seem to have high angularity.

Prior to constructing the new overlay, the existing pavement surface should be evaluated to determine its structural integrity. The pavement should be in good condition; it should have proper longitudinal and transverse grades and a watertight surface that is free of major cracks, depressions, or any other surface irregularities. For minor cracks, normal maintenance procedures should be followed prior to construction of overlay. Any rubber deposits should be removed from the runway surface prior to constructing the overlay. In addition, all paving should be constructed with appropriate transverse slope for basic drainage and must have adequate provision for prompt removal of storm runoff (FAA, 1997).

It should be noted that painted areas of wet runway pavement surfaces can become very slippery. Differential braking of an aircraft may occur when one main gear is on a painted surface, and the other on an unpainted surface. It is therefore important to keep the skid-resistance properties of painted surfaces as close to that of unpainted surfaces as possible. This can be accomplished by adding a small amount of silica sand or glass

beads to the paint to increase the friction properties of the painted surface. Glass beads are also used to increase the conspicuity of paint markings (FAA, 1997).

References

- Airfield Asphalt Pavement Technology Program. (2010). *Guideline for Prevention and Mitigation of Non-Load Associated Distresses*. Auburn University, Alabama: AMEC
- Airfield Asphalt Pavement Technology Program. (2007). *Improved Porous Friction Courses (PFC) on Asphalt Airfield Pavements*. Volume I: Final Report for AAPTTP Project 04-06, Mississippi: Burns, Cooley, Dennis Inc.
- Allard, M. & Lemay, M. (2012). *Nunavik and Nunatsiavut: From Science to Policy. An Integrated Regional Impact Study (IRIS) of climate change and modernization*. ArcticNet Inc.
- American Association of State Highway and Transportation Officials. (2005). M320-05 *Standard Specification for Performance-Graded Asphalt Binder*.
- American Meteorological Society. (2012). *Glossary of Meteorology – Rain*. Retrieved from <http://glossary.ametsoc.org/wiki/Rain>
- American Society of Testing and Materials. (2003). D 2041-03a *Standard Test Method for Theoretical Maximum Specific Gravity and Density of Bituminous Paving Mixtures*.
- American Society of Testing and Materials. (2004). D 6926-04 *Standard Practice for Preparation of Bituminous Specimens Using Marshall Apparatus*.
- American Society of Testing and Materials. (2005a). E 2380-05 *Standard Test Method for Measuring Pavement Texture Drainage Using an Outflow Meter*.
- American Society of Testing and Materials. (2005b). E 2172-05 *Standard Test Methods for Quantitative Extraction of Bitumen From Bituminous Paving Mixtures*.
- American Society of Testing and Materials. (2005c). D 2726-05a *Standard Test Method for Bulk Specific Gravity and Density of Non-Absorptive Compacted Bituminous Mixtures*.

American Society of Testing and Materials. (2005d). D 3203-05 *Standard Test Method for Percent Air Voids in Compacted Dense and Open Bituminous Paving Mixtures*.

American Society of Testing and Materials. (2006a). E 965-96 (Reapproved 2006) *Standard Test Method for Measuring Macrotexture Depth Using a Volumetric Technique*.

American Society of Testing and Materials. (2006b). D 6927-06 *Standard Test Method for Marshall Stability and Flow of Bituminous Mixtures*.

American Society of Testing and Materials. (2006c). D 5-06 *Standard Test Method for Penetration of Bituminous Materials*.

American Society of Testing and Materials. (2006d). C 136-06 *Standard Test Method for Sieve Analysis of Fine and Coarse Aggregates*.

American Society of Testing and Materials. (2008). E 303-93 (Reapproved 2008) *Standard Test Method for Measuring Surface Frictional Properties Using the British Pendulum Tester*.

American Society of Testing and Materials. (2010). D5340 *Standard Test Method for Airport Pavement Condition Index Surveys*.

Canada Maps. (n.d.). Retrieved from <http://www.canada-maps.org/quebec-map.htm>

Centre for Northern Studies. (2012). *Evaluations des Conditions du Pergelisol Sous La Piste 07-25 De L'Aéroport de Kuujjuaq, Rapport Final*.

Clariant. (n.d.), Division Functional Chemicals. Safeway SF Runway de-icer product sheet.

Québec Ministre des Transports. (n.d.). *Enrobe semi-grenu ESG-10*. Direction du Laboratoire des Chaussées, Fiche no. 003-01, Sainte-Foy, QC

- Federal Aviation Administration. (1997). *Advisory Circular: Measurement, Construction and Maintenance of Skid Resistant Airport Pavement Surfaces*. AC 150/5320-12C.
- FloorSlip UK. (2013). Retrieved from <http://www.pendulum-test.co.uk/buy-pendulum-tester.html>
- Gransberg, D. (2009). *Life-Cycle Cost Analysis of Surface Rertexturing with Shotblasting as an Asphalt Pavement Preservation Tool*. Transportation Research Record: Journal of the Transportation Research Board, No. 2108, Transportation Research Board of the National Academies, Washington, DC.
- International Civil Aviation Organization. (2002). Doc 9137 AN/898 *Airport Services Manual Part 2 Pavement Surface Conditions*, Fourth Edition.
- International Civil Aviation Organization. (2012). Cir 329 AN/191 *Runway Surface Condition Assessment, Measurement and Reporting*.
- International Slurry Surfacing Association (2013). *What is Slurry?* Retrieved from <http://www.slurry.org/index.php/education/issa-disciplines-guidelines/what-is-slurry>
- Kativik Regional Government. (2013). *Transportation Department – Airports*. Retrieved from <http://www.krg.ca/en/airports>
- Liu, Y. (2004). *Effect of Surface Macrotecture on Skid Resistance Measurements by the British Pendulum Test*. Journal of Testing and Evaluation. Vol.32, No.4.
- National Driller. (2001). Retrieved from <http://www.nationaldriller.com/articles/84394-skidabrader-anti-skid-process-textures-longest-bridge-in-the-world>
- Northwest Territories Transportation. (2012). *Runway Grooving*, Normal Wells, NWT. SWIFT Conference 2012.
- National Highway Cooperative Research Program. (2009). Web-Only Document 108: Guide for Pavement Friction, Project 01-43, 2009.

Pinto, S. (2012). *Optimizing Airport Runway Performance by Managing Pavement Infrastructure*. University of Waterloo, Waterloo, ON

Skid Resistance (Surface Friction) Tester (n.d.). MASTRAD Quality and Test Systems. Retrieved from <http://www.mastrad.com/griptest.htm>

Tradewind Scientific Ltd. (2011). *Kuujuuaq Airport Special Runway Friction Testing and Texture Measurement Summary Report*, Report #282-11-YVP1 (Rev.2), Ottawa, ON

Transport Canada. (2004). Aerodrome Safety Circular: *Guidelines Respecting the Measurement, Evaluation and Maintenance of Airfield Pavement Surface Friction*. ASC-2004-024.

Transport Canada. (2012). Advisory Circular: *Runway Grooving*. AC 300-008.

Transportation Safety Board. (2011). Aviation Investigation Report A11A0035, *Runway Overrun, Kelowna Flightcraft Air Charter Ltd., St.John's Newfoundland and Labrador*.

Uzarowski, L., Paradis, M., & Lum, P. (2004). *Accelerated Performance Testing of Canadian Asphalt Mixes Using Three Different Wheel Rut Testers*, Paper for presentation, Transportation Association of Canada, Québec City, Québec.

Appendix A
Supplemental Graphs Showing 2013 and 2011 Friction Testing Data

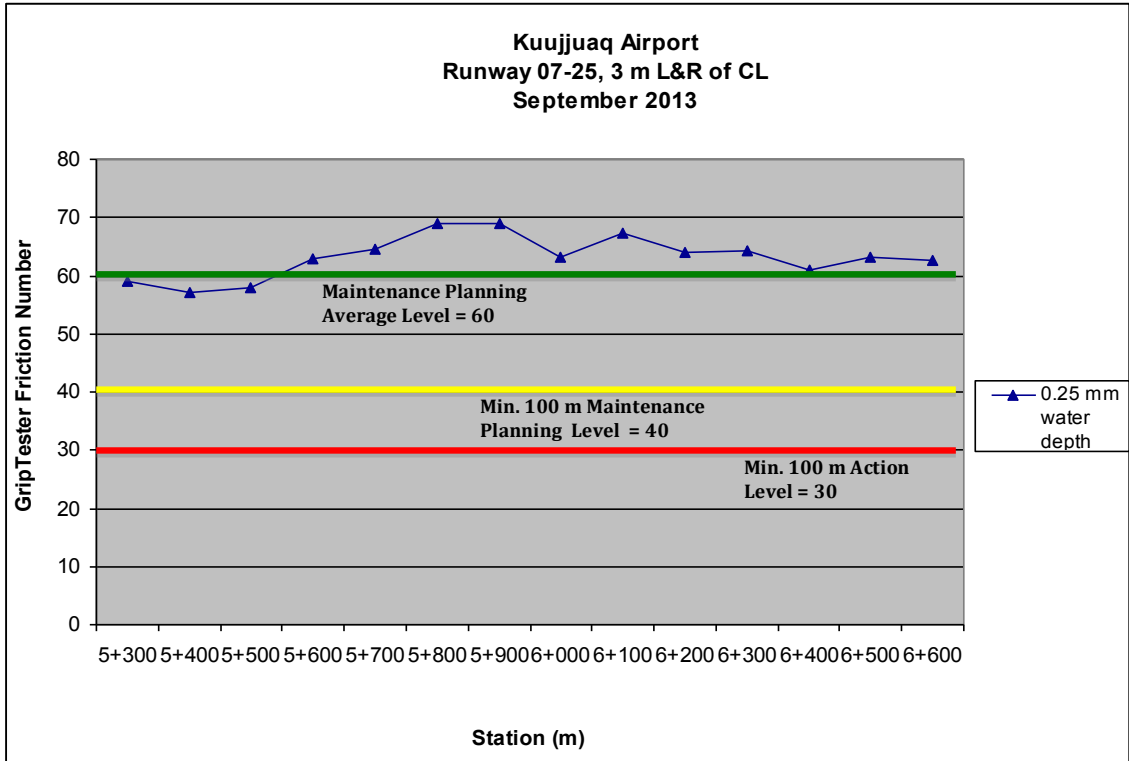

Figure A.1 2013 GripTester friction results, average of 3 m L&R offsets, 0.25 mm water depth

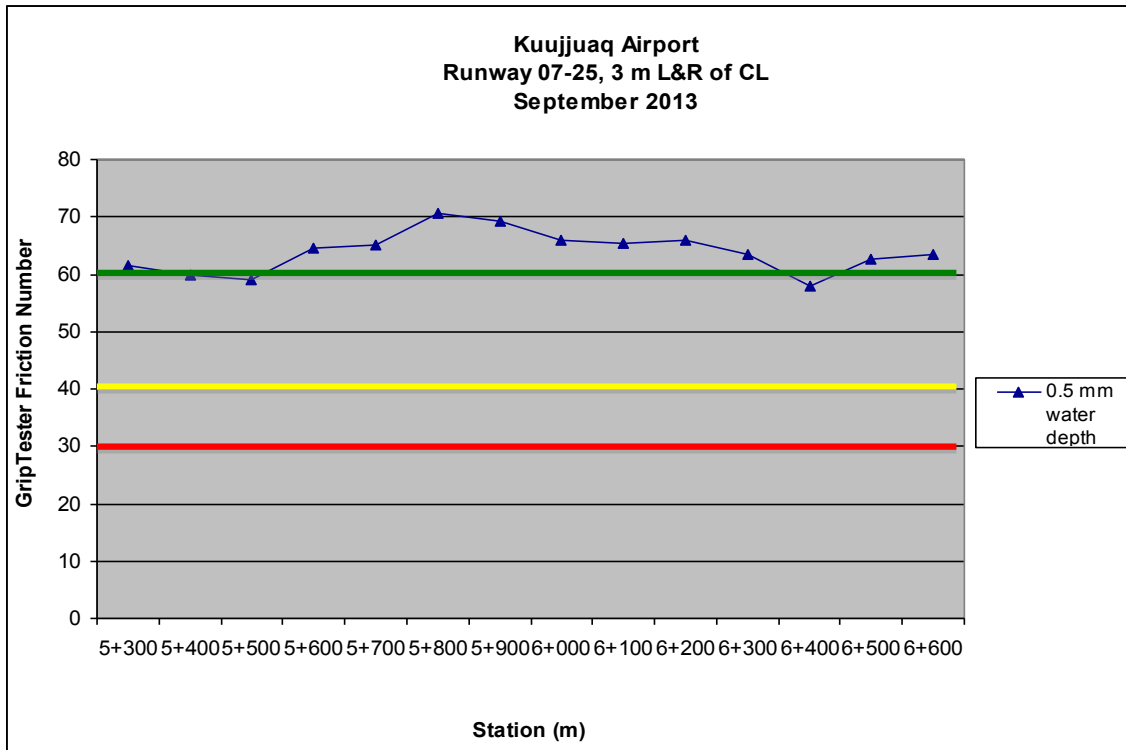

Figure A.2 2013 GripTester friction results, average of 3 m L&R offsets, 0.5 mm water depth

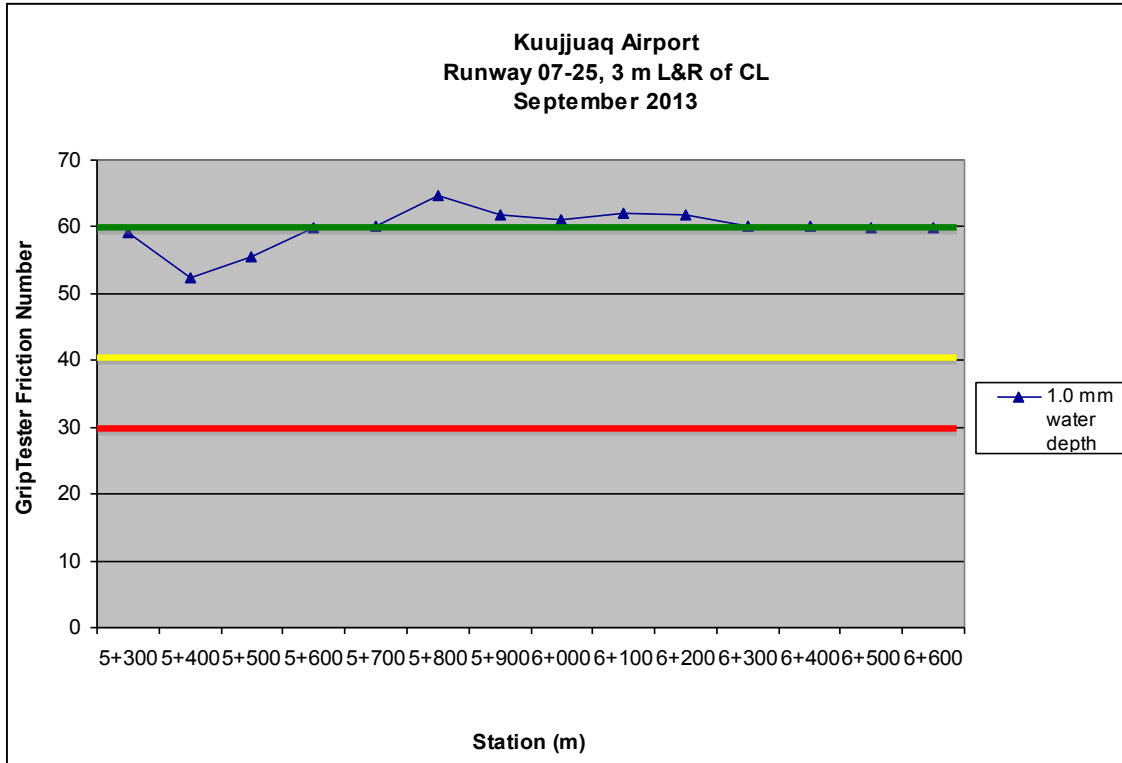

Figure A.3 2013 GripTester friction results, average of 3 m L&R Offsets, 1.0 mm water depth

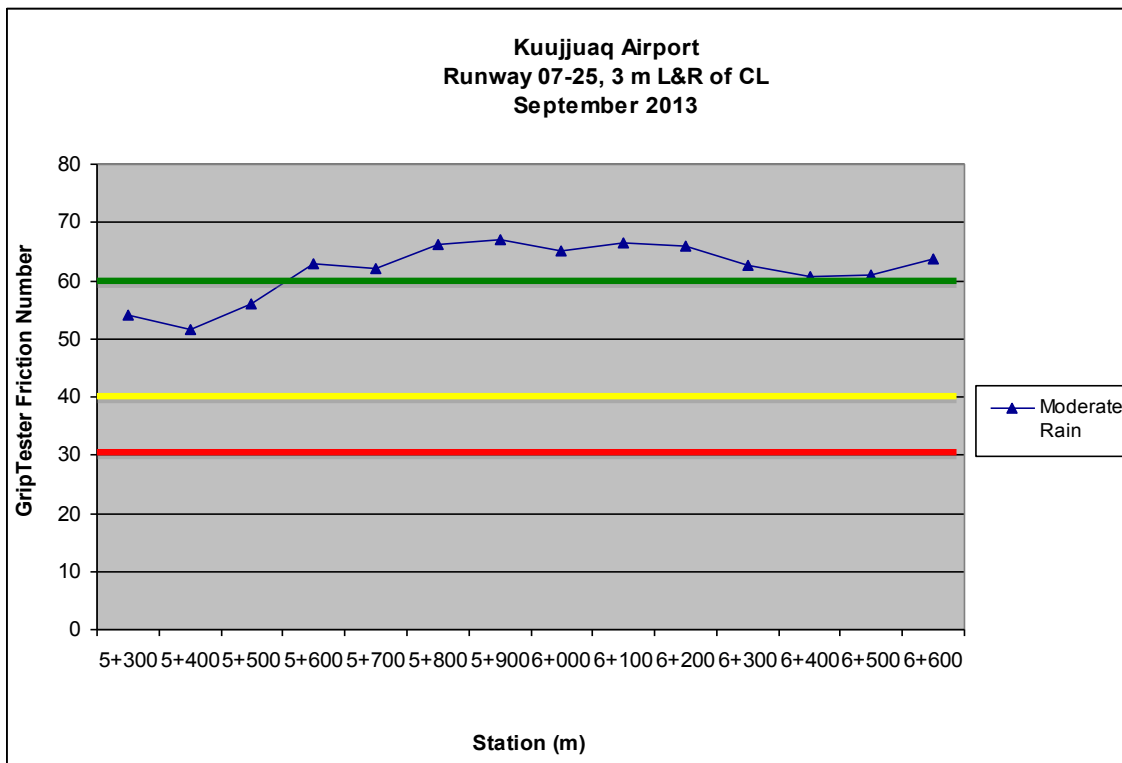

Figure A.4 2013 GripTester friction results, average of 3 m L&R offsets, moderate rain

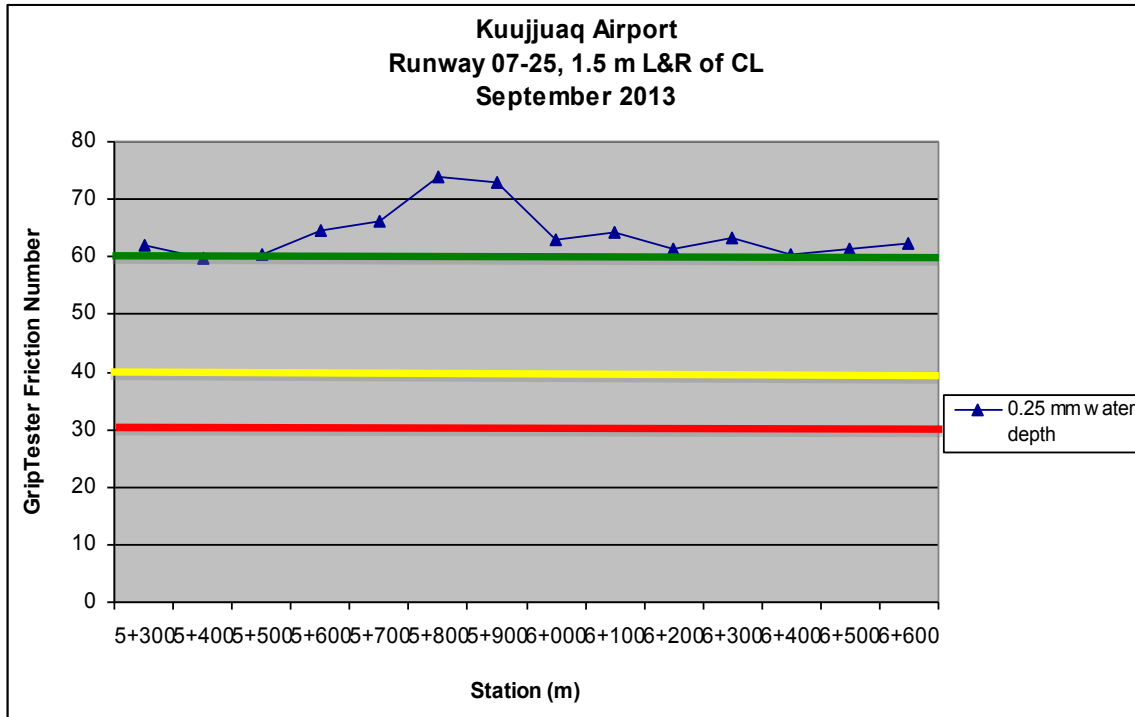

Figure A.5 2013 GripTester friction results, average of 1.5 m L&R offsets, 0.25 mm water depth

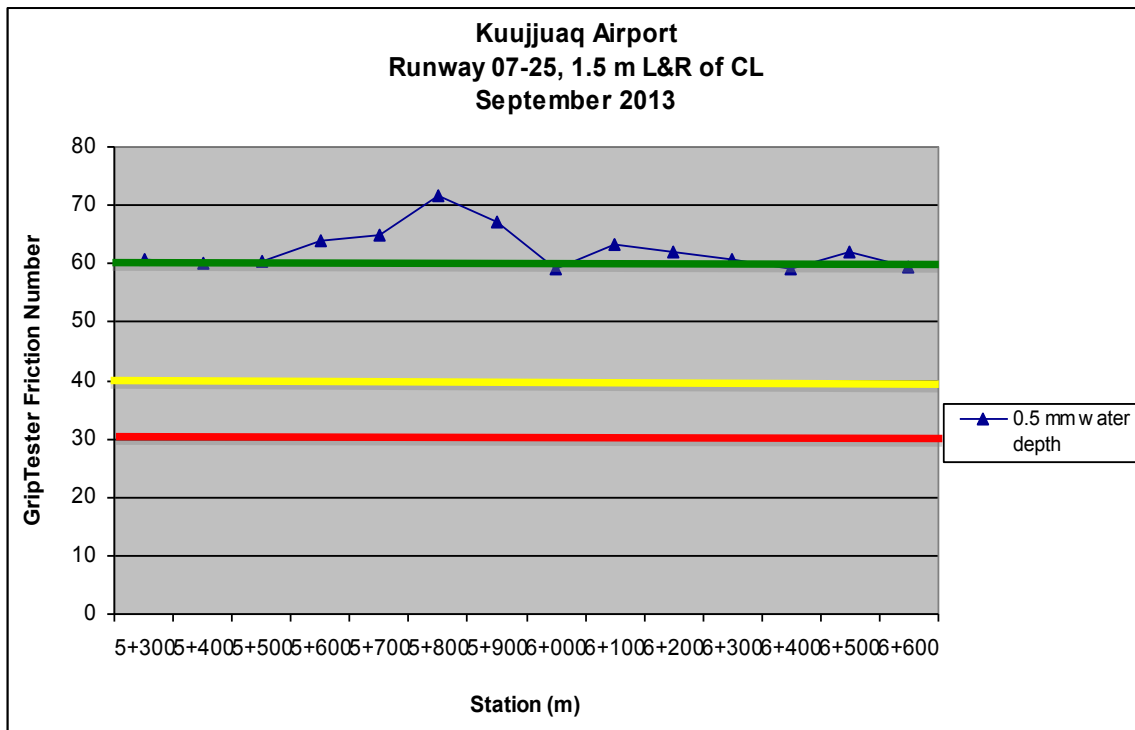

Figure A.6 2013 GripTester friction results, average of 1.5 m L&R offsets, 0.5 mm water depth

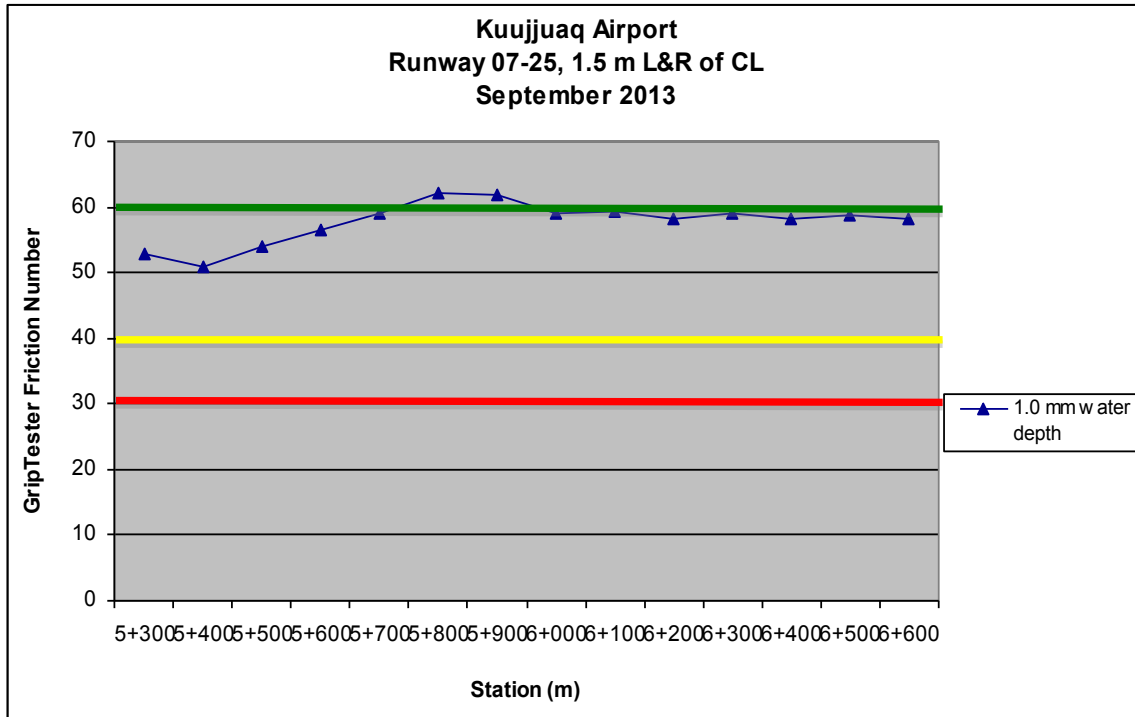

Figure A.7 2013 GripTester friction results, average of 1.5 m L&R offsets, 1.0 mm water depth

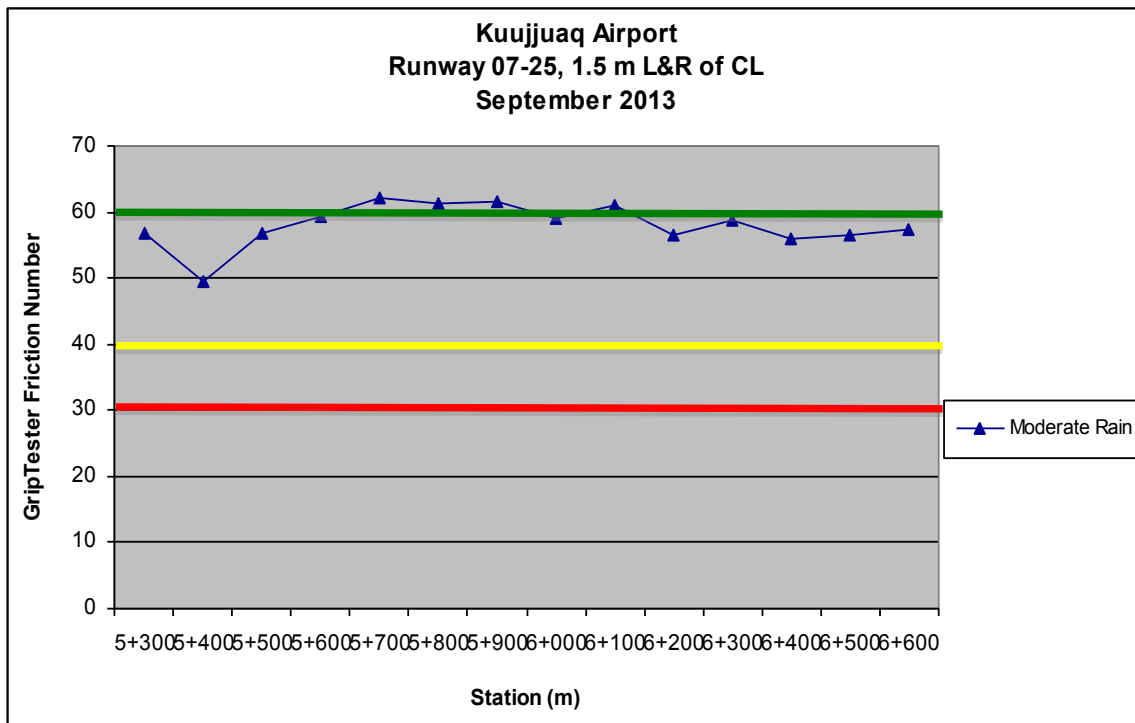

Figure A.8 2013 GripTester friction results, average of 1.5 m L&R offsets, moderate rain

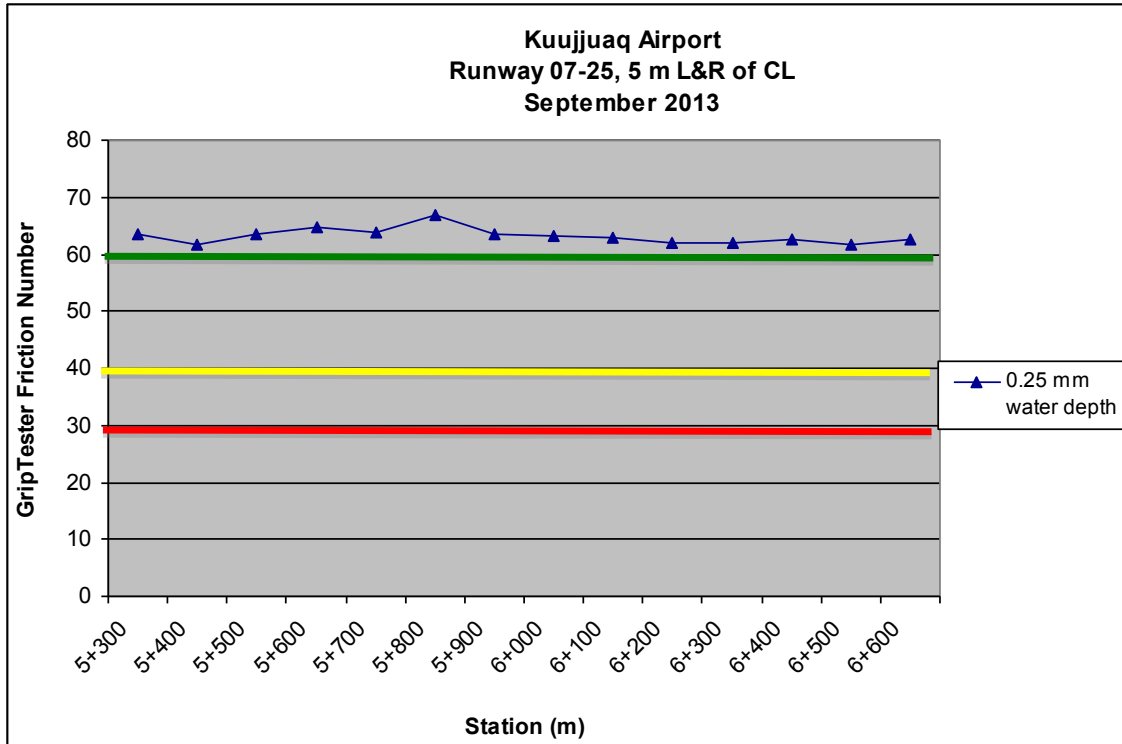

Figure A.9 2013 GripTester friction results, average of 5 m L&R Offsets, 0.25 mm water depth

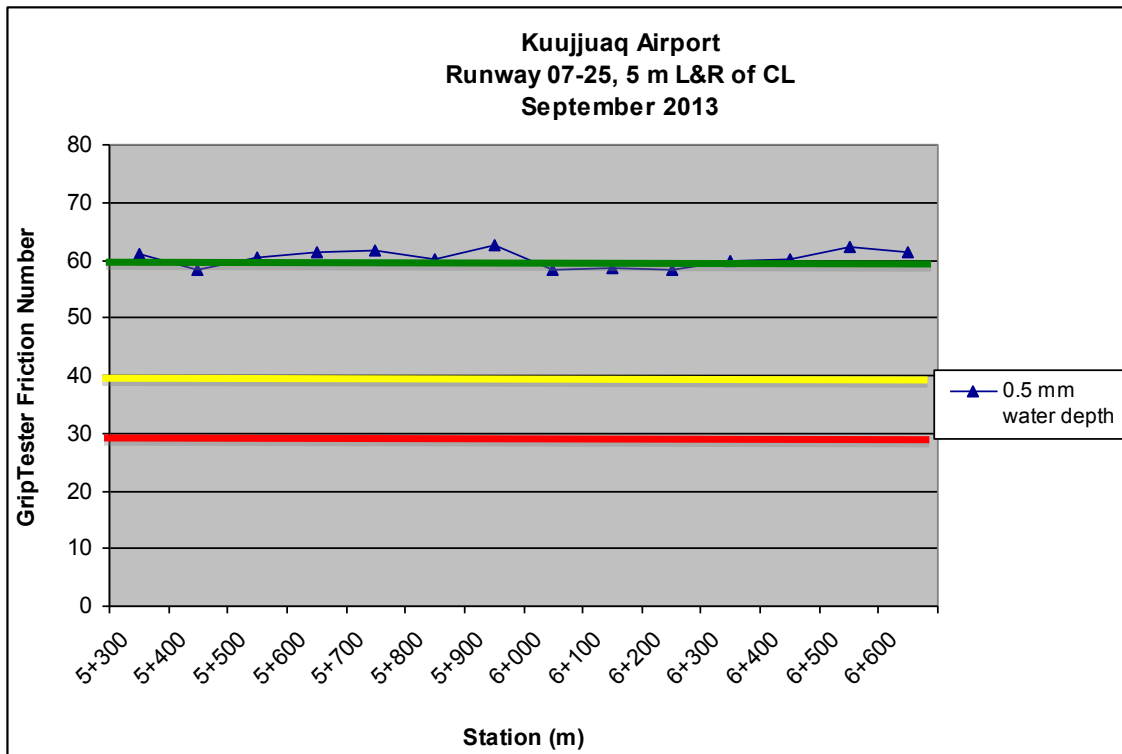

Figure A.10 2013 GripTester friction results, average of 5 m L&R offsets, 0.5 mm water depth

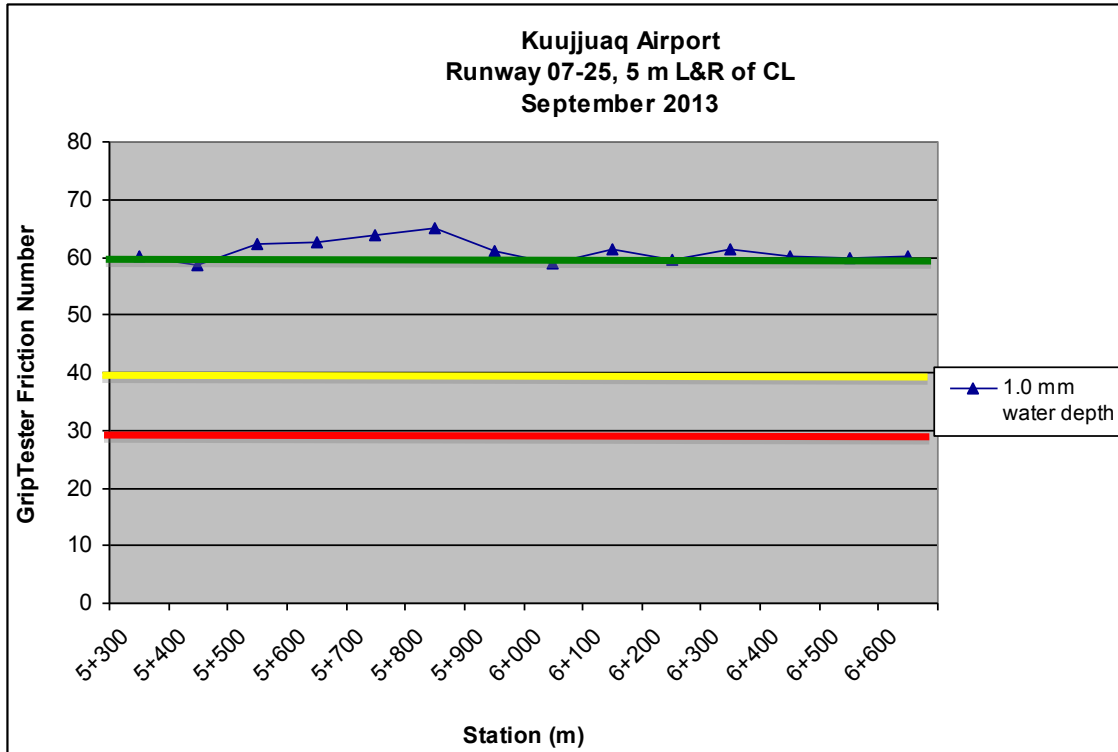

Figure A.11 2013 GripTester friction results, average of 5 m L&R Offsets, 1.0 mm water depth

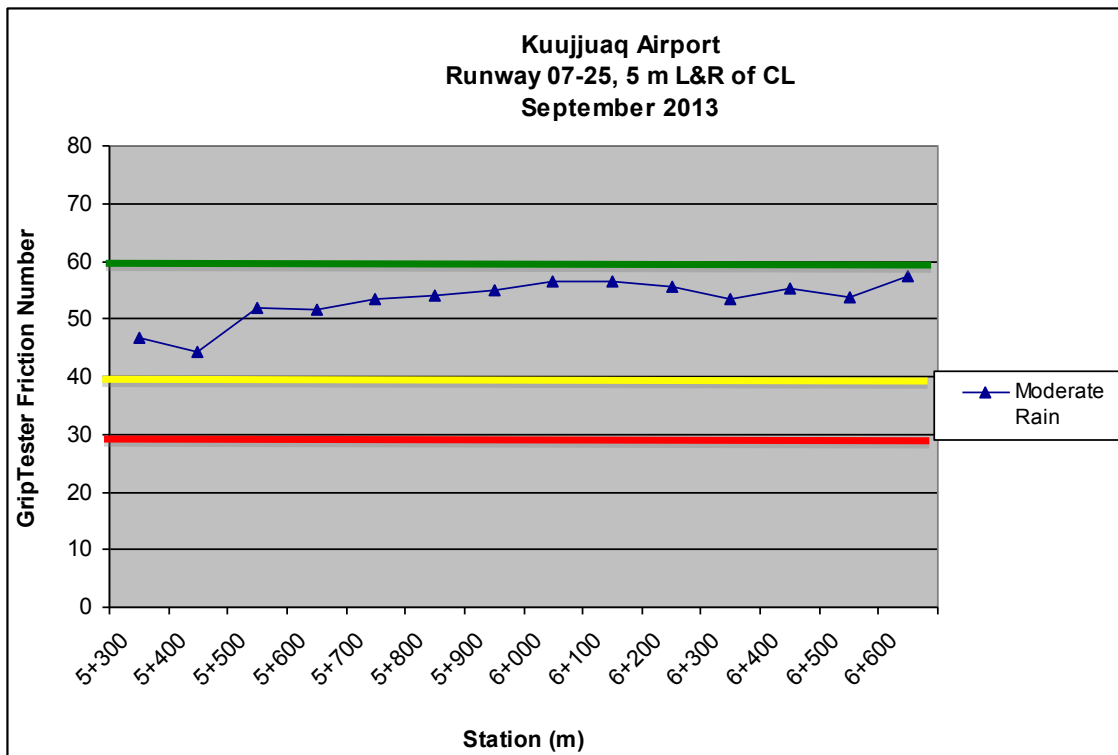

Figure A.12 2013 GripTester friction results, average of 5 m L&R offsets, moderate rain

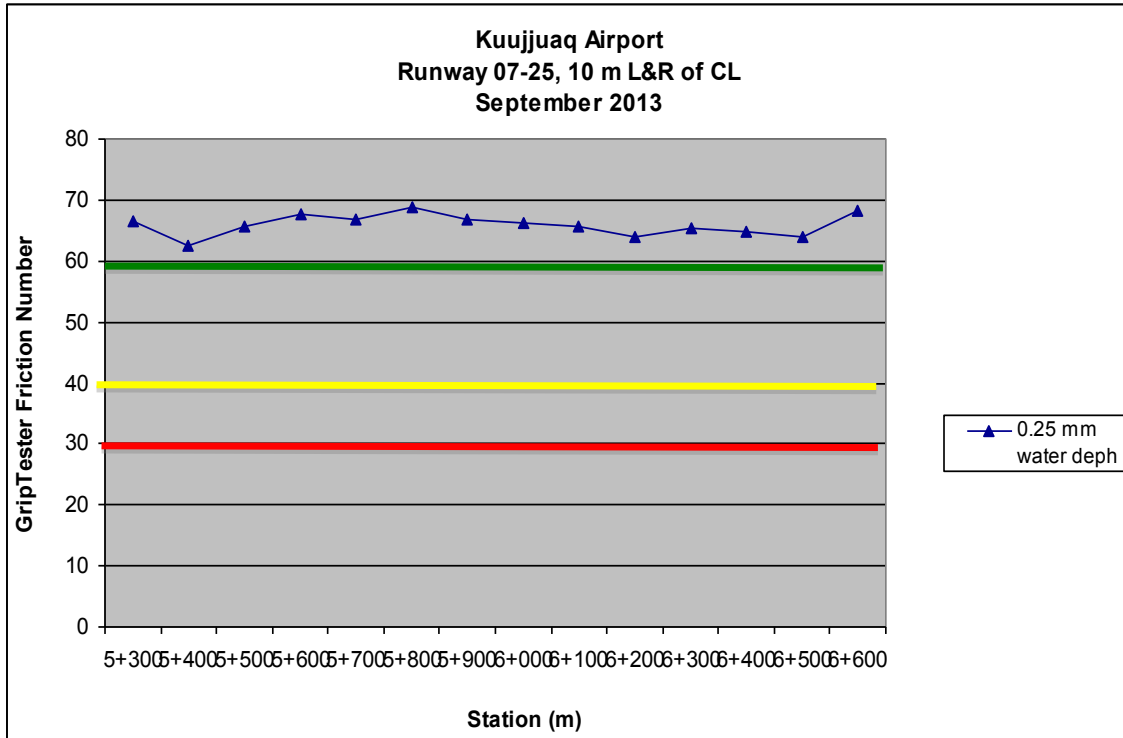

Figure A.13 2013 GripTester friction results, average of 10 m L&R offsets, 0.25 mm water depth

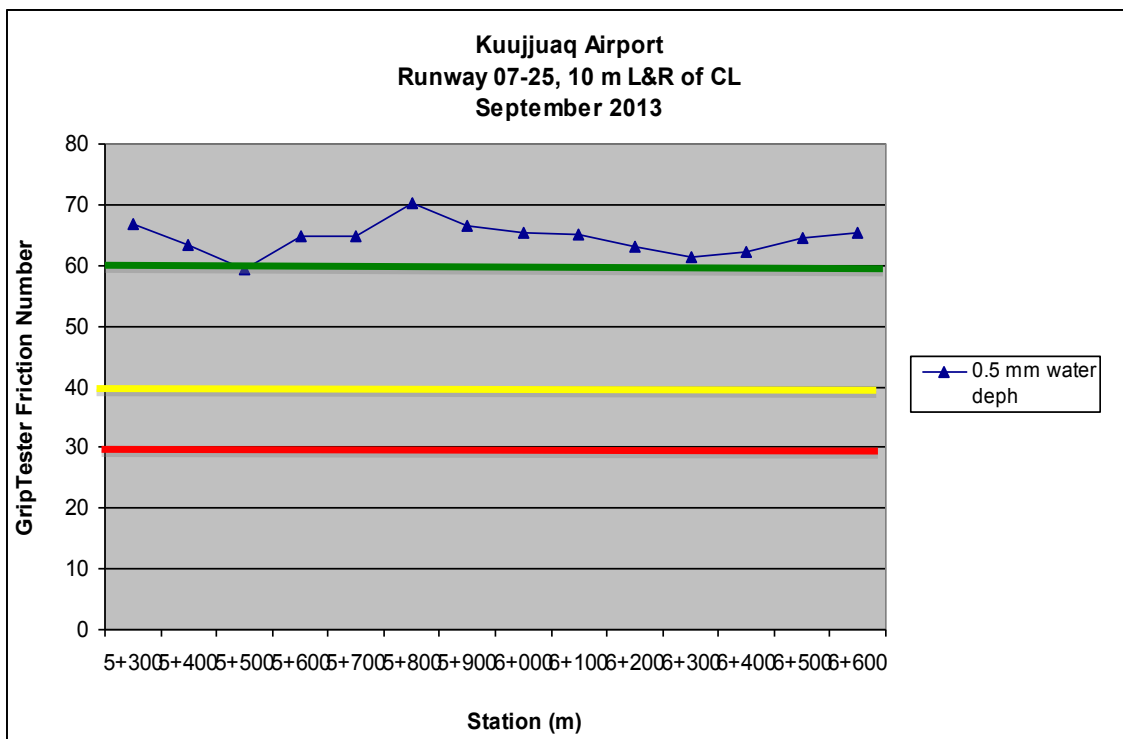

Figure A.14 2013 GripTester friction results, average of 10 m L&R offsets, 0.5 mm water depth

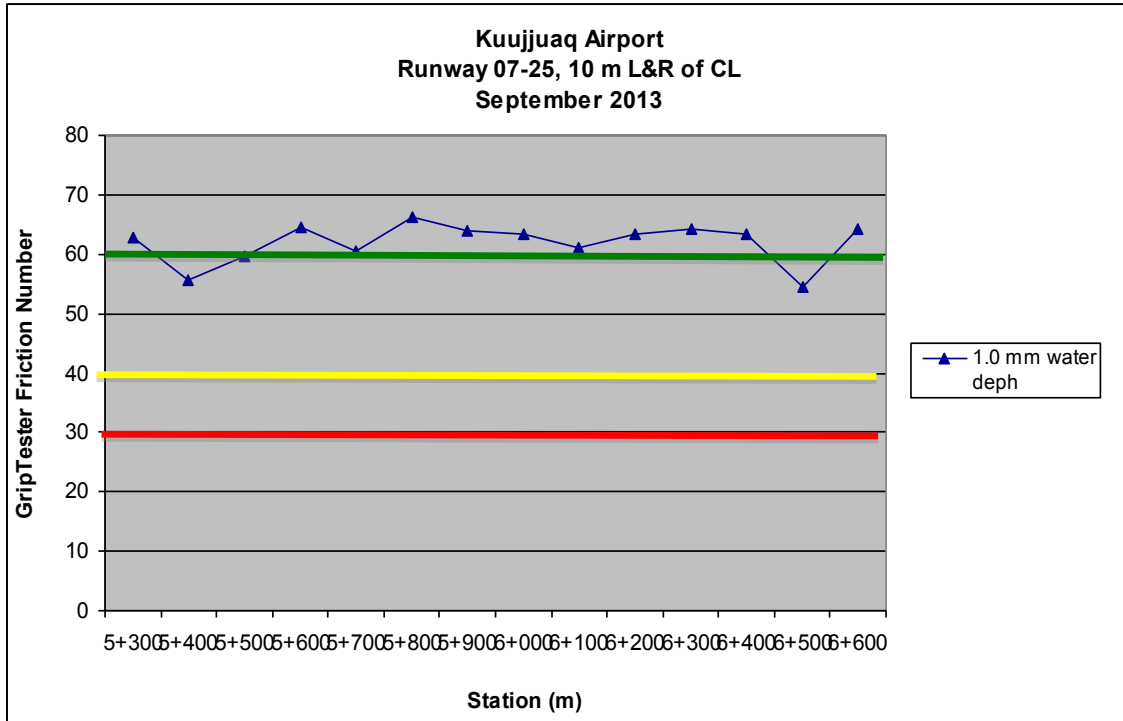

Figure A.15 2013 GripTester friction results, average of 10 m L&R offsets, 1.0 mm water depth

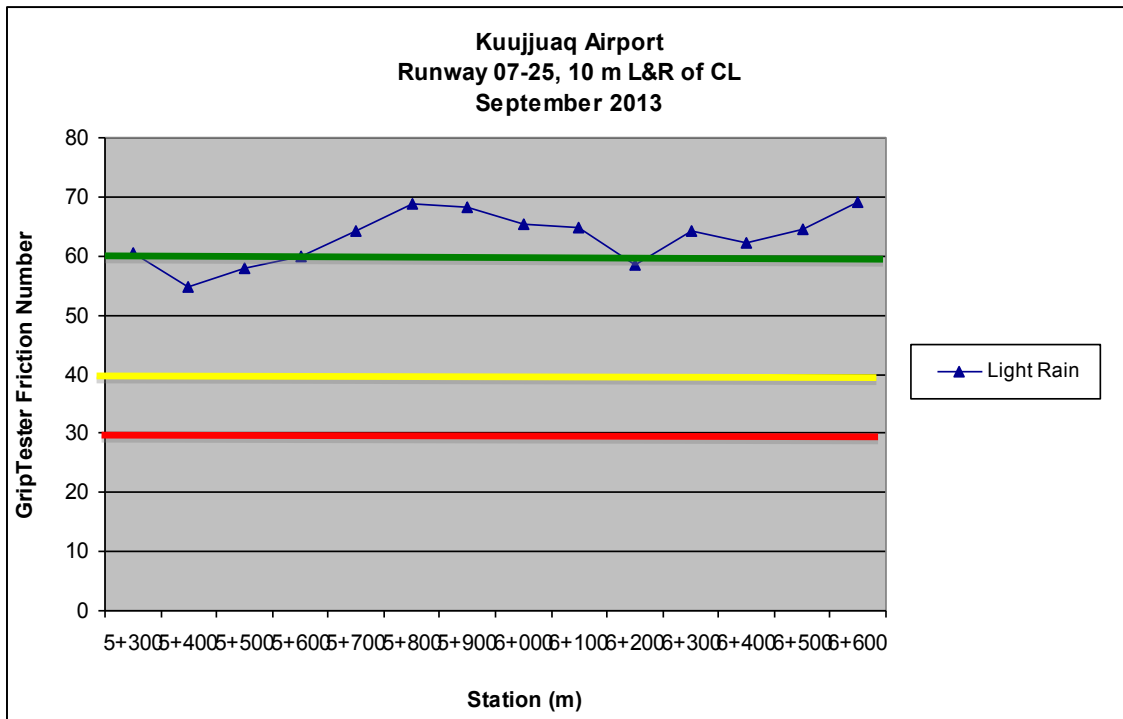

Figure A.16 2013 GripTester friction results, average of 10 m L&R offsets, light rain

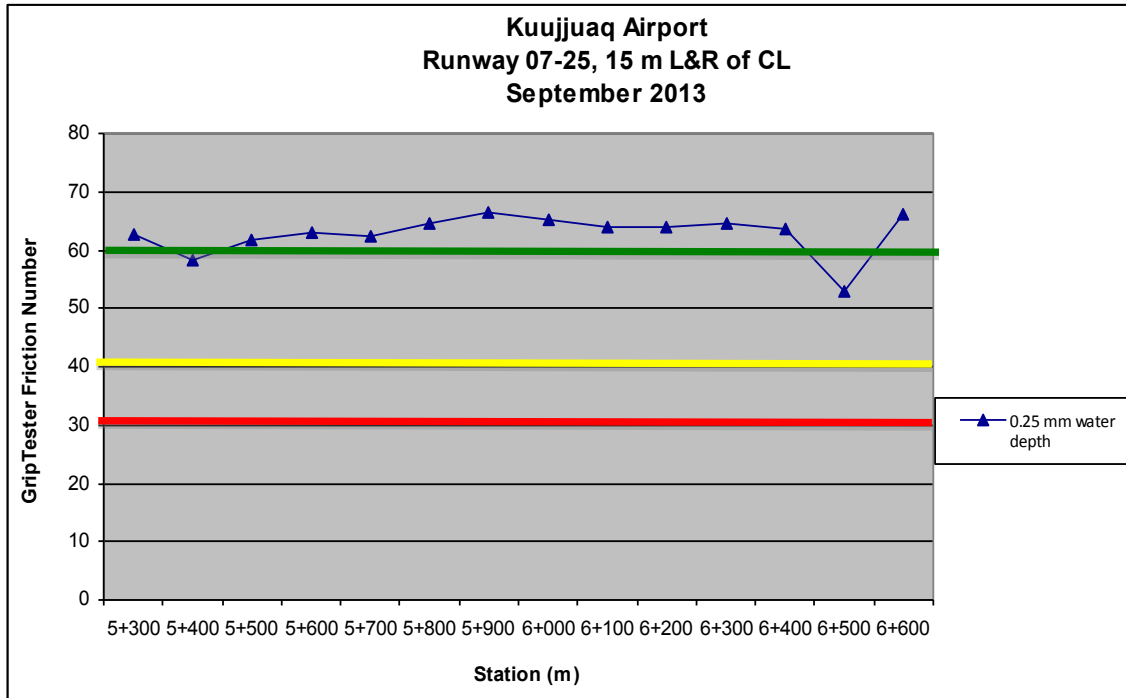

Figure A.17 2013 GripTester friction results, average of 15 m L&R offsets, 0.25 mm water depth

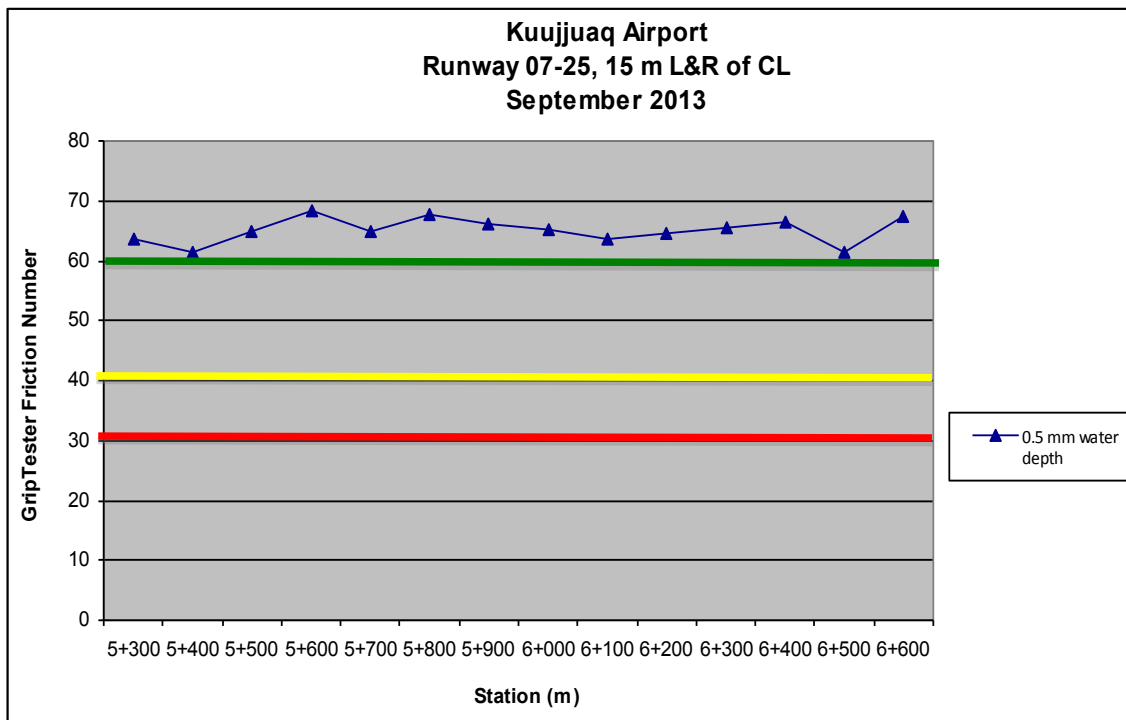

Figure A.18 2013 GripTester friction results, average of 15 m L&R Offsets, 0.5 mm water depth

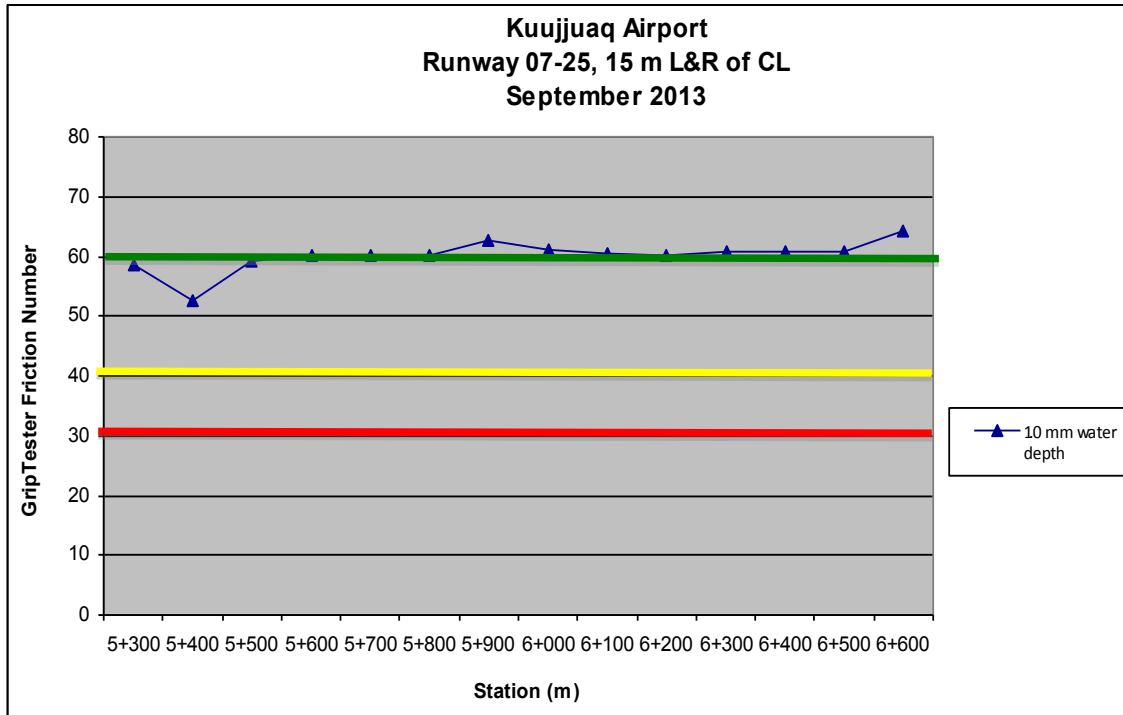

Figure A.19 2013 GripTester friction results, average of 15 m L&R offsets, 1.0 mm water depth

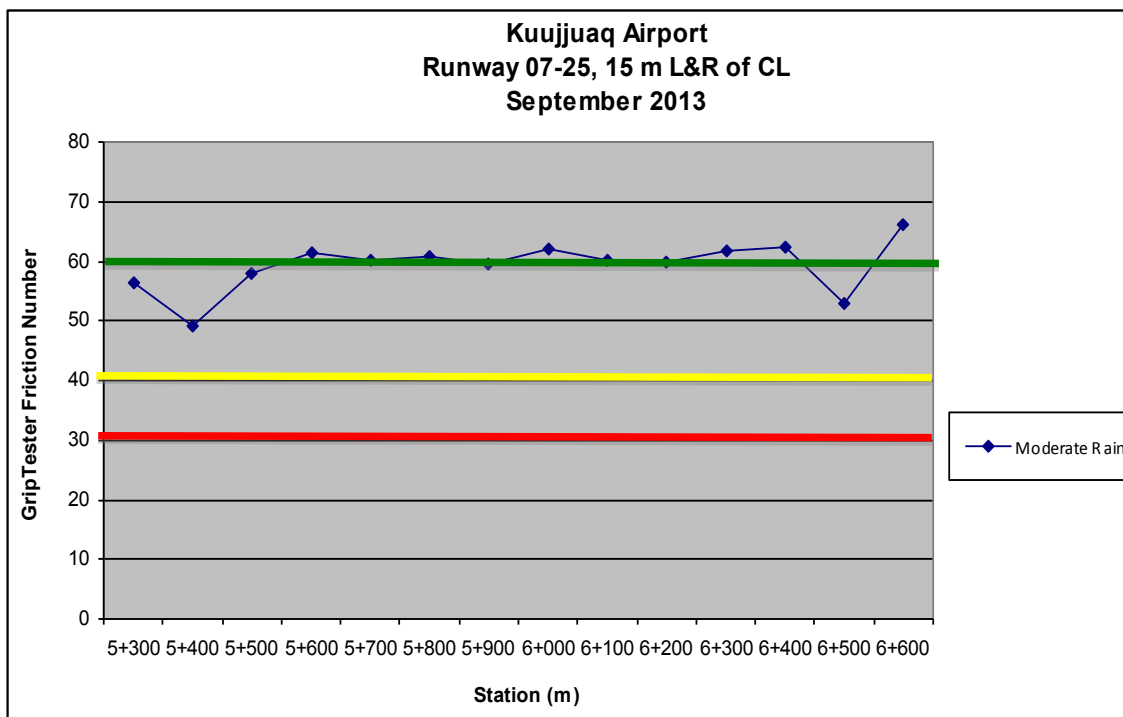

Figure A.20 2013 GripTester friction results, average of 15 m L&R offsets, moderate rain

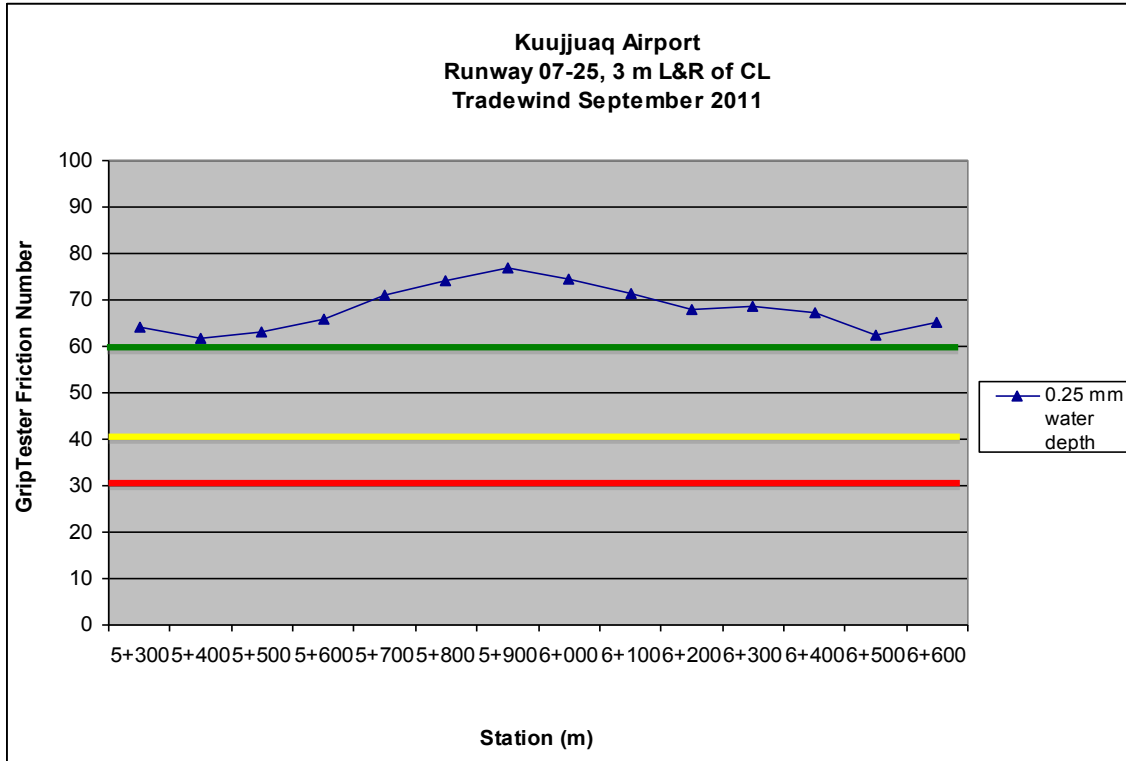

Figure A.21 2011 GripTester friction results, average of 3 m L&R offsets, 0.25 mm water depth

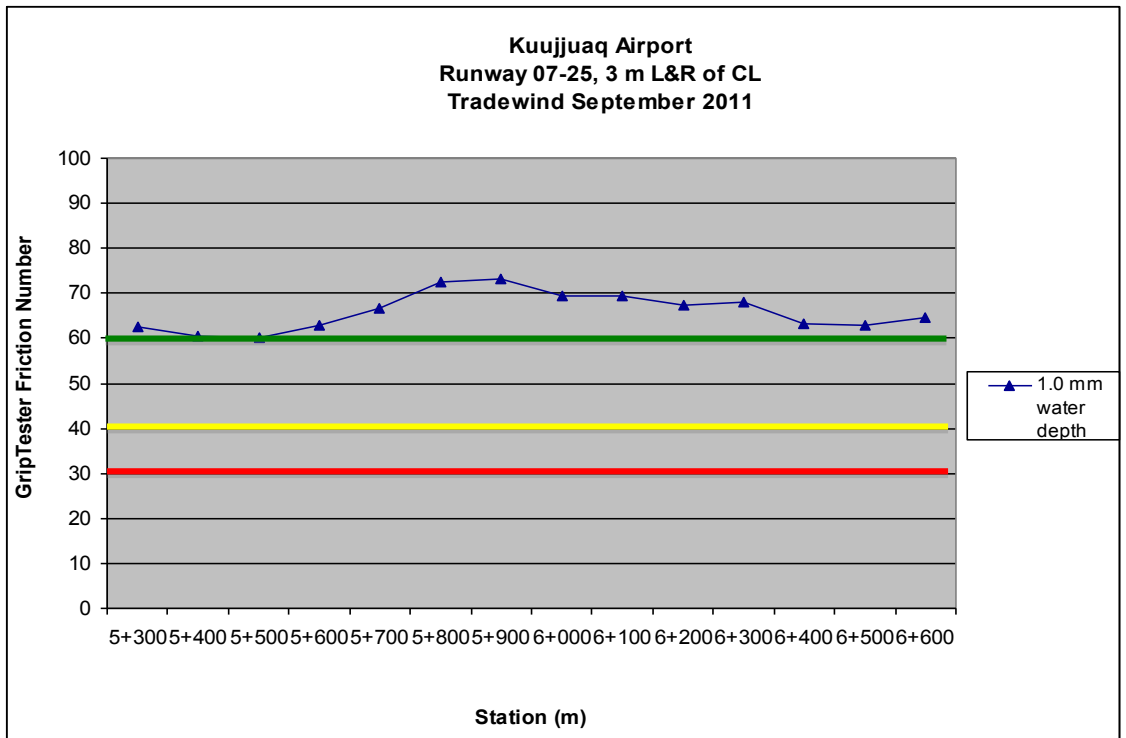

Figure A.22 2011 GripTester friction results, average of 3 m L&R offsets, 1.0 mm water depth

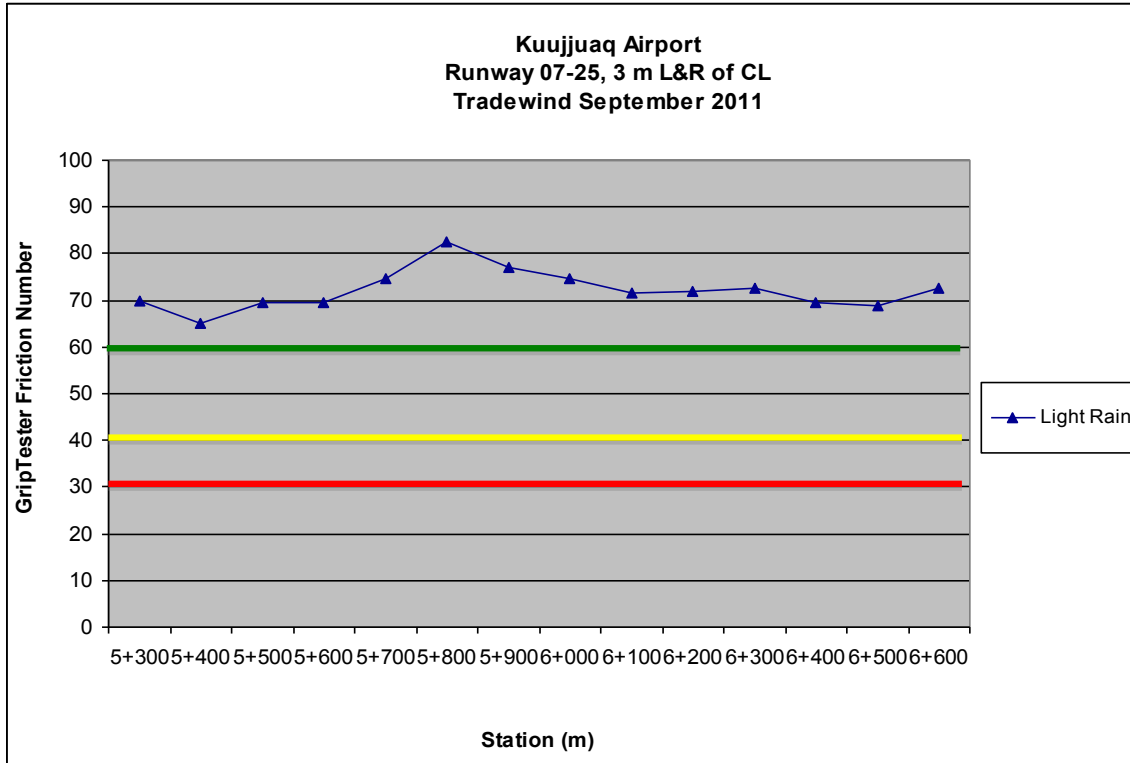

Figure A.23 2011 GripTester friction results, average of 3 m L&R Offsets, light rain

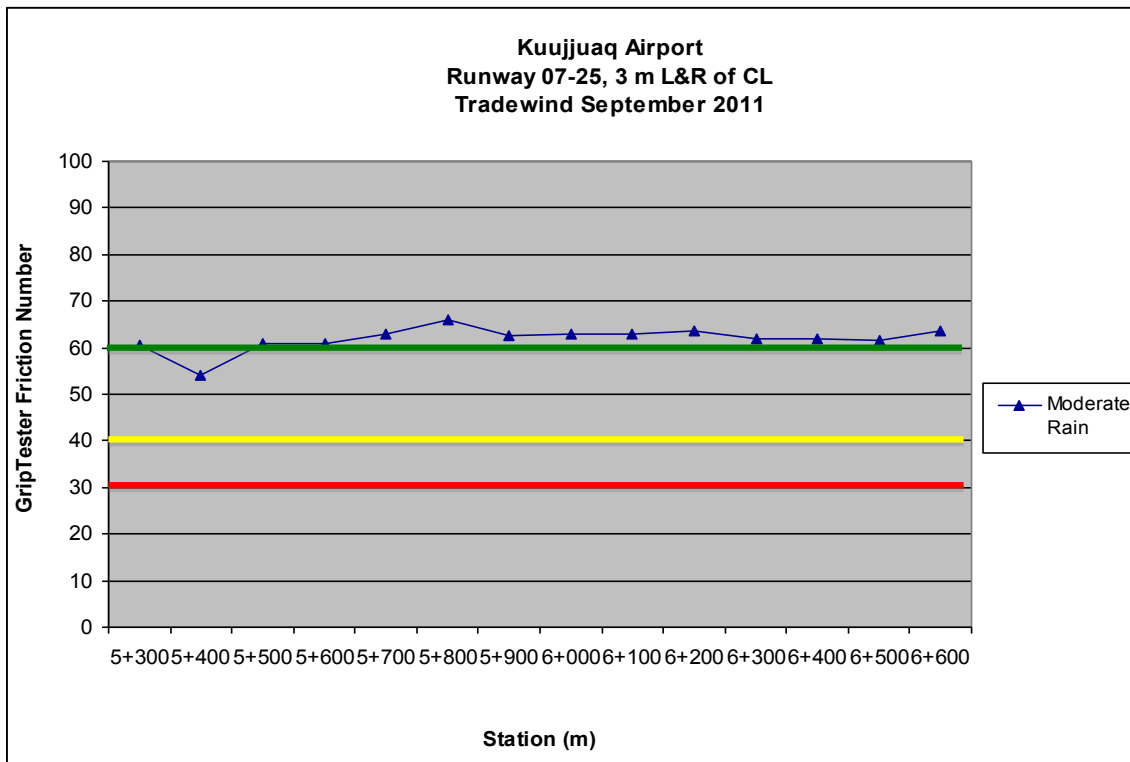

Figure A.24 2011 GripTester friction results, average of 3 m L&R offsets, moderate rain

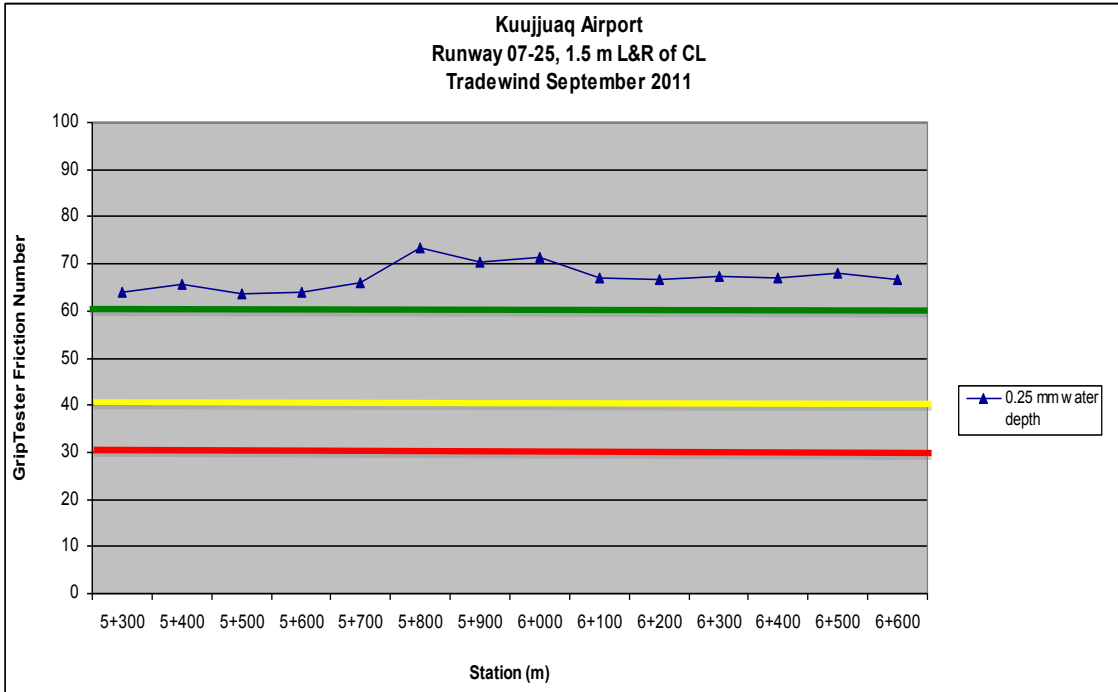

Figure A.25 2011 GripTester friction results, average of 1.5 m L&R offsets, 0.25 mm water depth

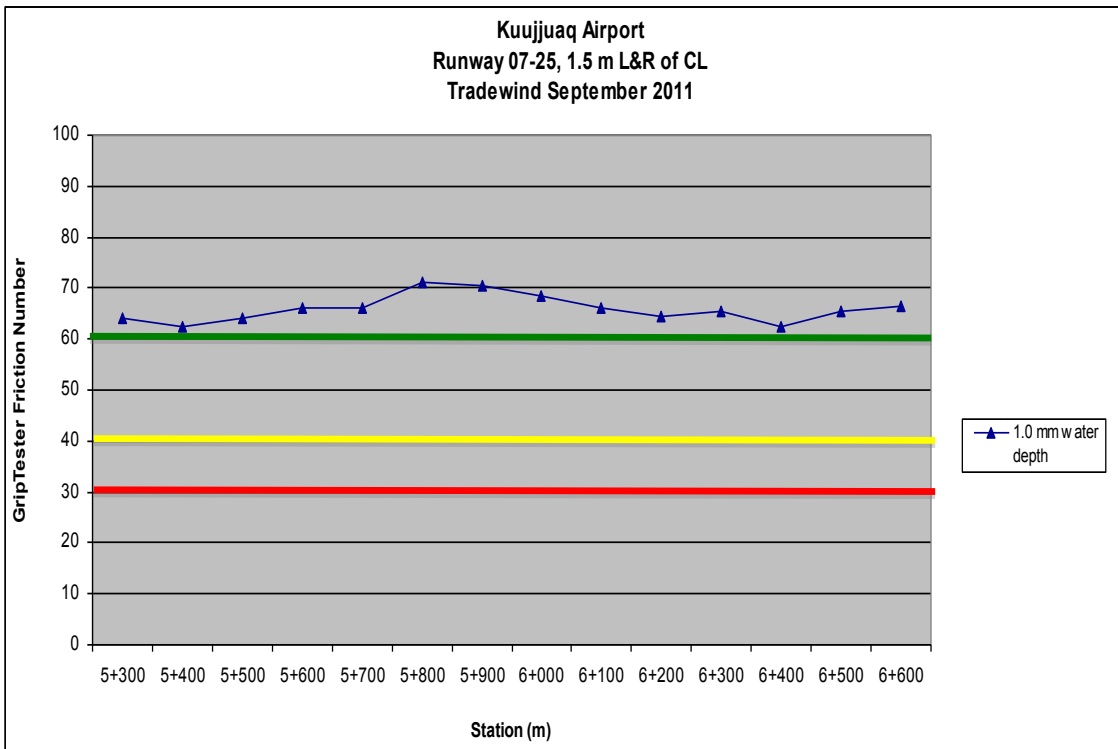

Figure A.26 2011 GripTester friction results, average of 1.5 m L&R offsets, 1.0 mm water depth

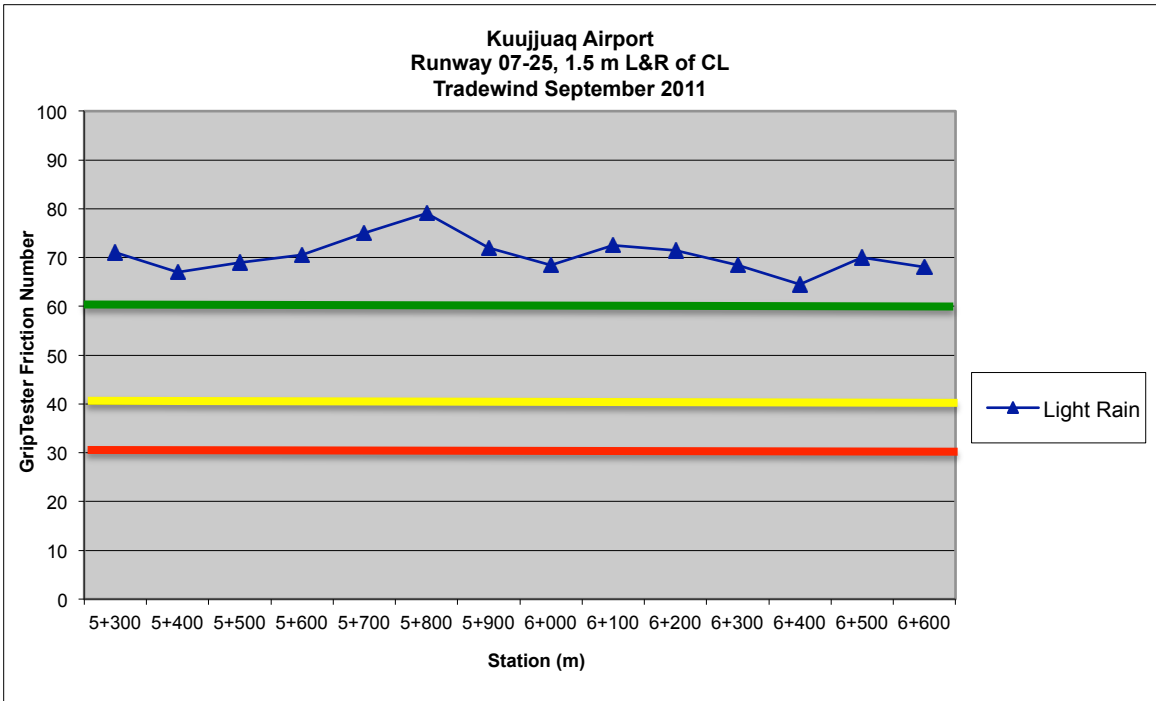

Figure A.27 2011 GripTester friction results, average of 1.5 m L&R offsets, light rain

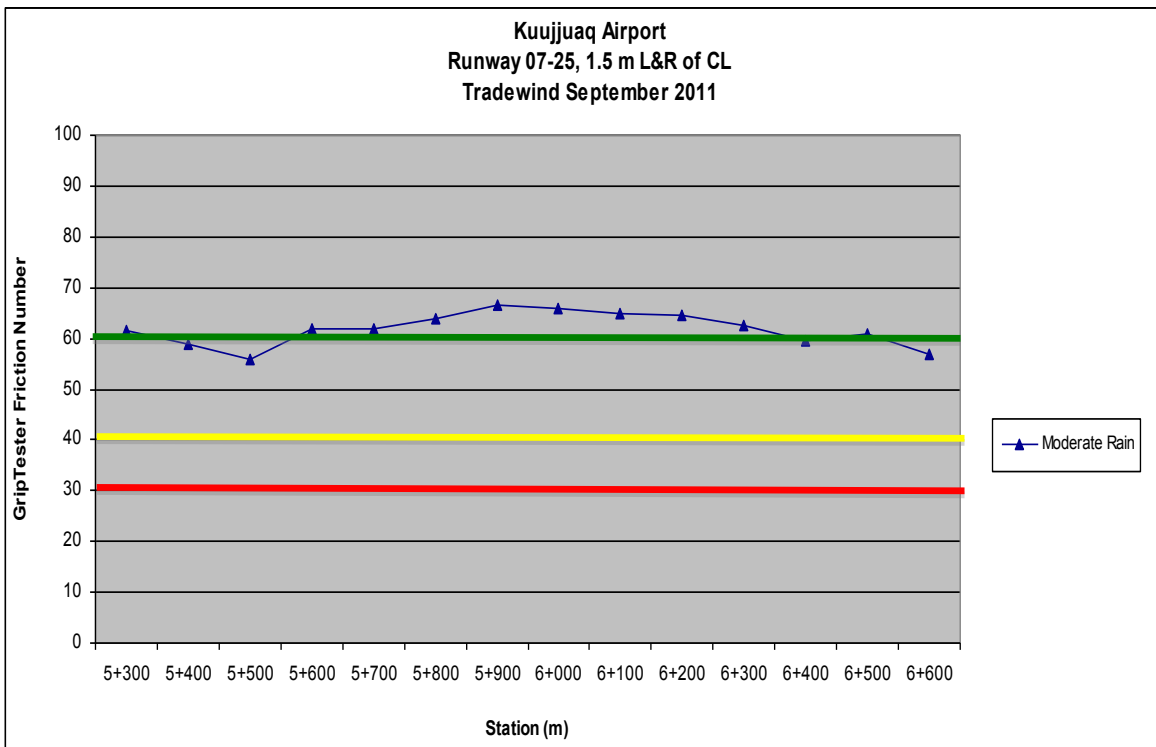

Figure A.28 2011 GripTester friction results, average of 1.5 m L&R offsets, moderate rain

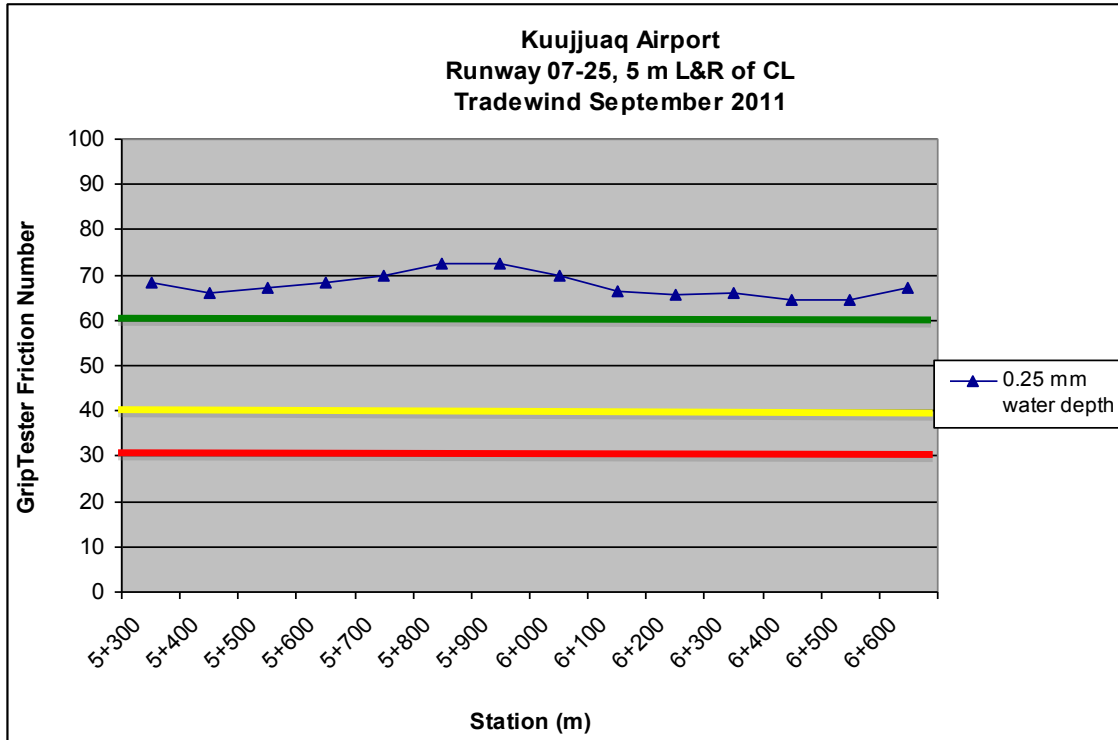

Figure A.29 2011 GripTester friction results, average of 5 m L&R offsets, 0.25 mm water depth

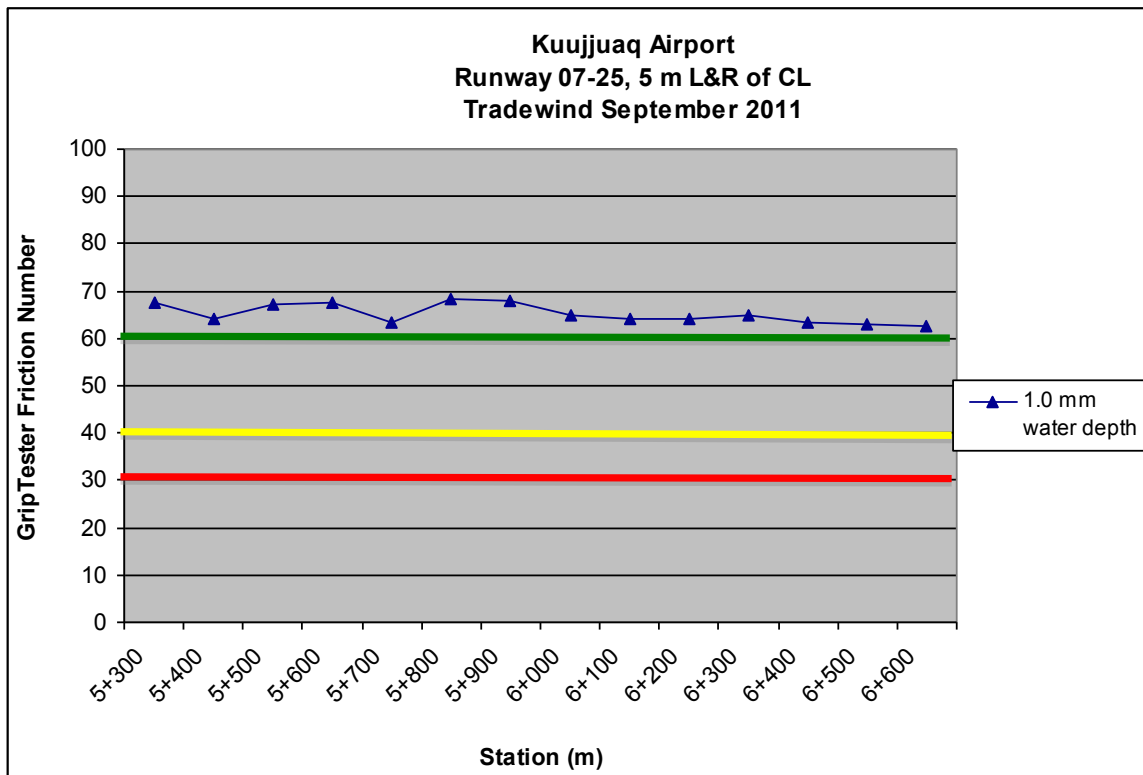

Figure A.30 2011 GripTester friction results, average of 5 m L&R offsets, 1.0 mm water depth

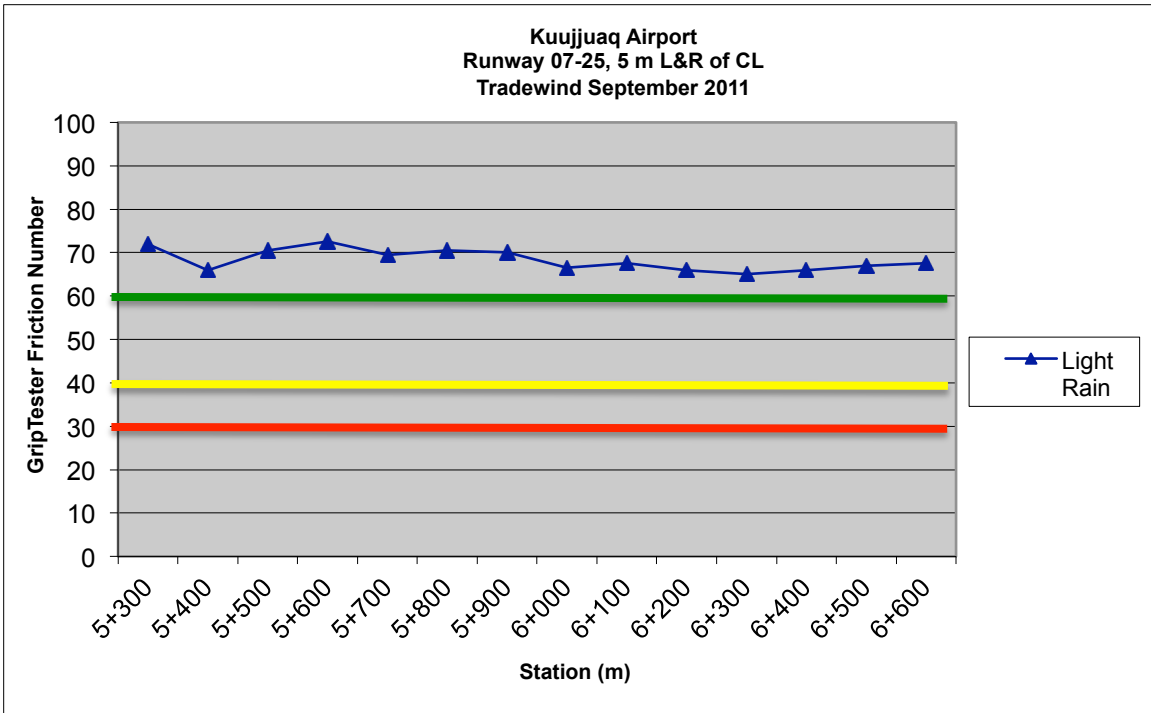

Figure A.31 2011 GripTester friction results, average of 5 m L&R offsets, light rain

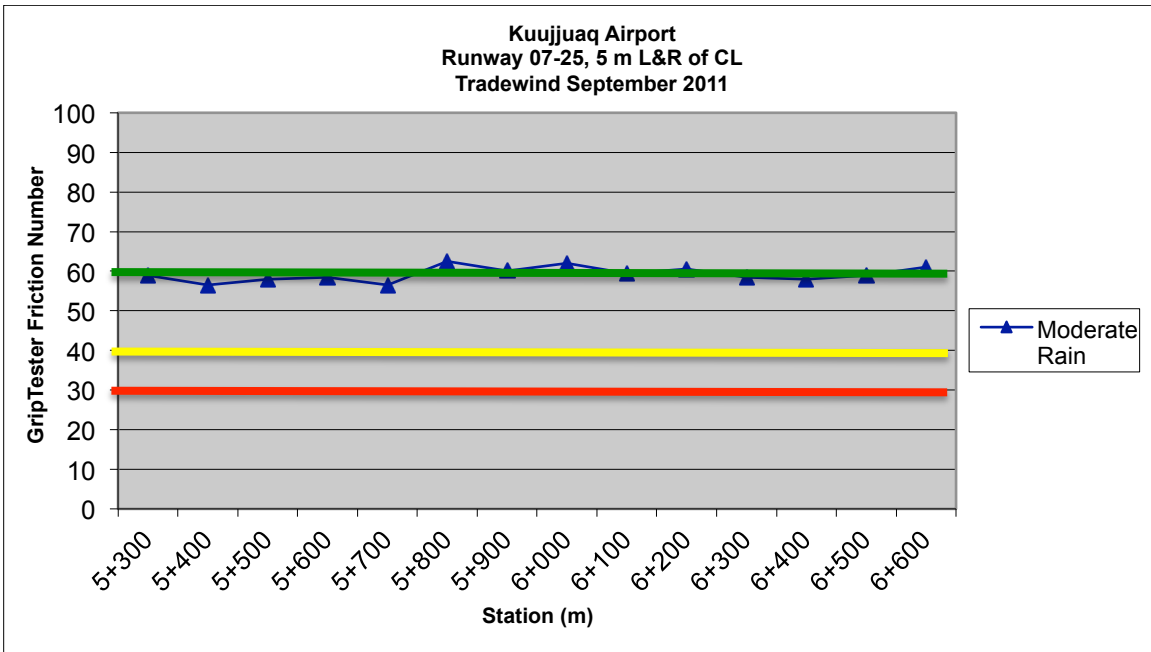

Figure A.32 2011 GripTester friction results, average of 5 m L&R offsets, moderate rain

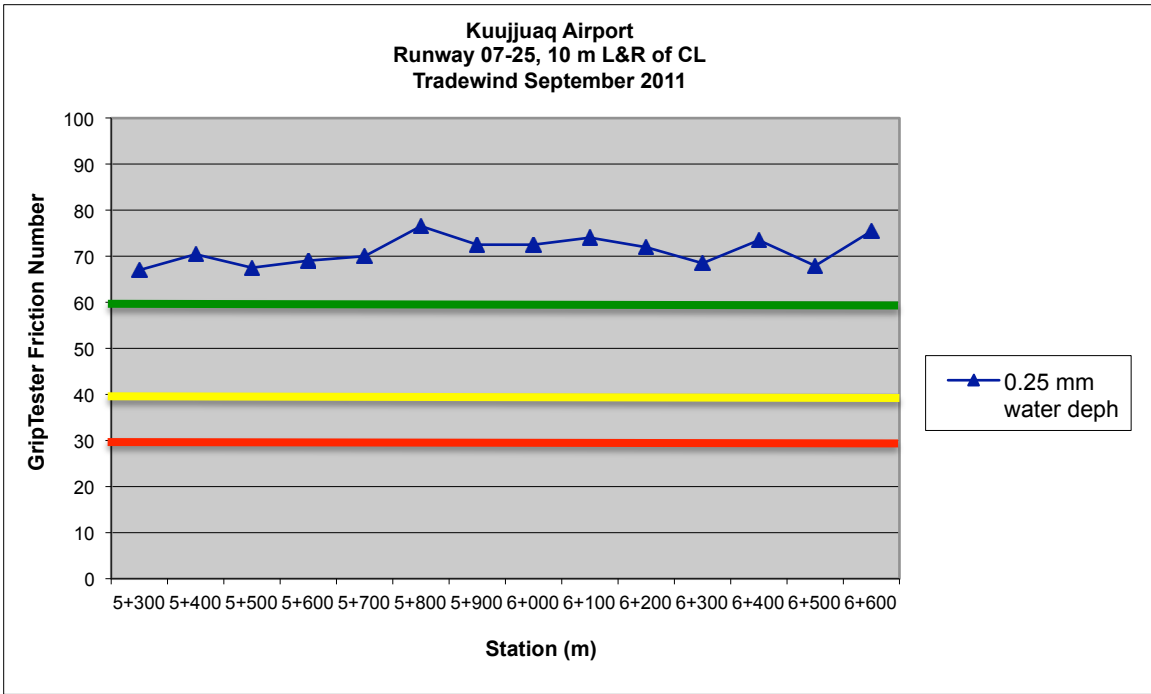

Figure A.33 2011 GripTester friction results, average of 10 m L&R offsets, 0.25 mm water depth

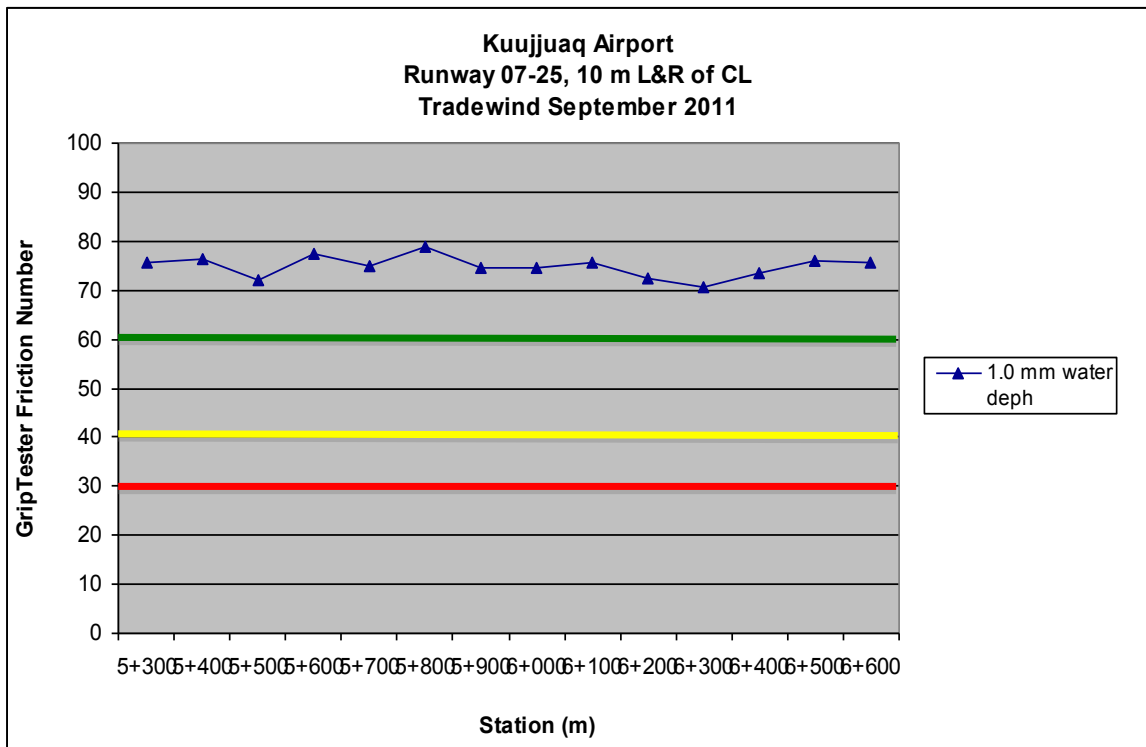

Figure A.34 2011 GripTester friction results, average of 10 m L&R Offsets, 1.0 mm water depth

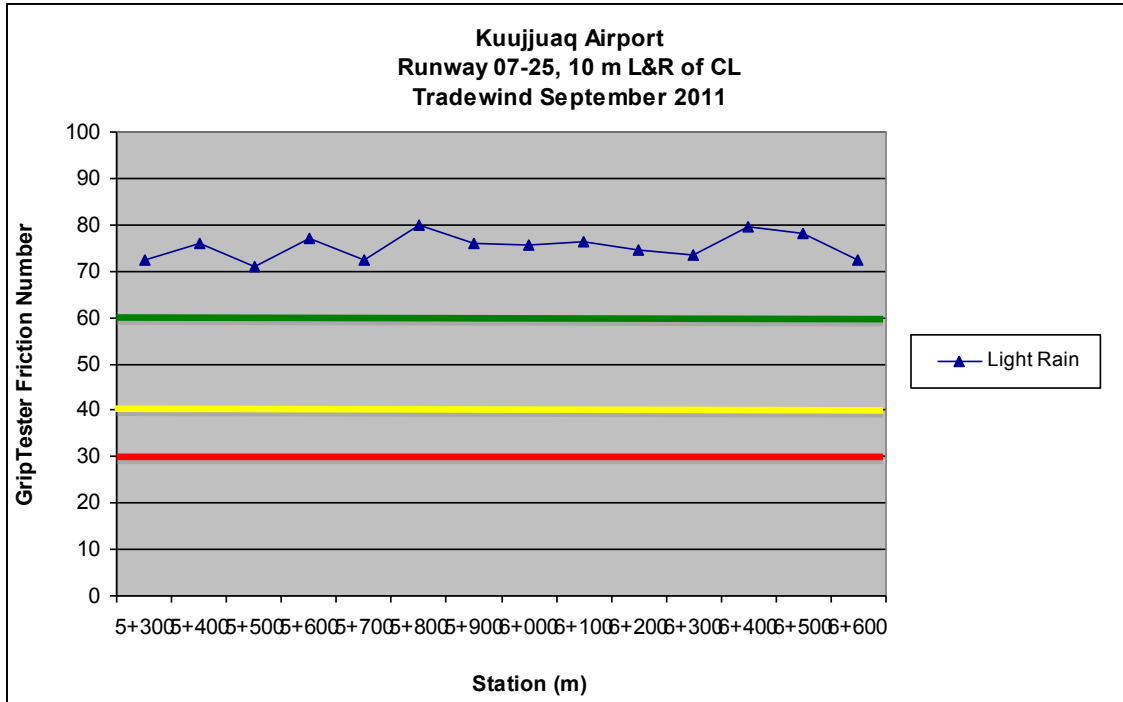

Figure A.35 2011 GripTester friction results, average of 10 m L&R offsets, light rain

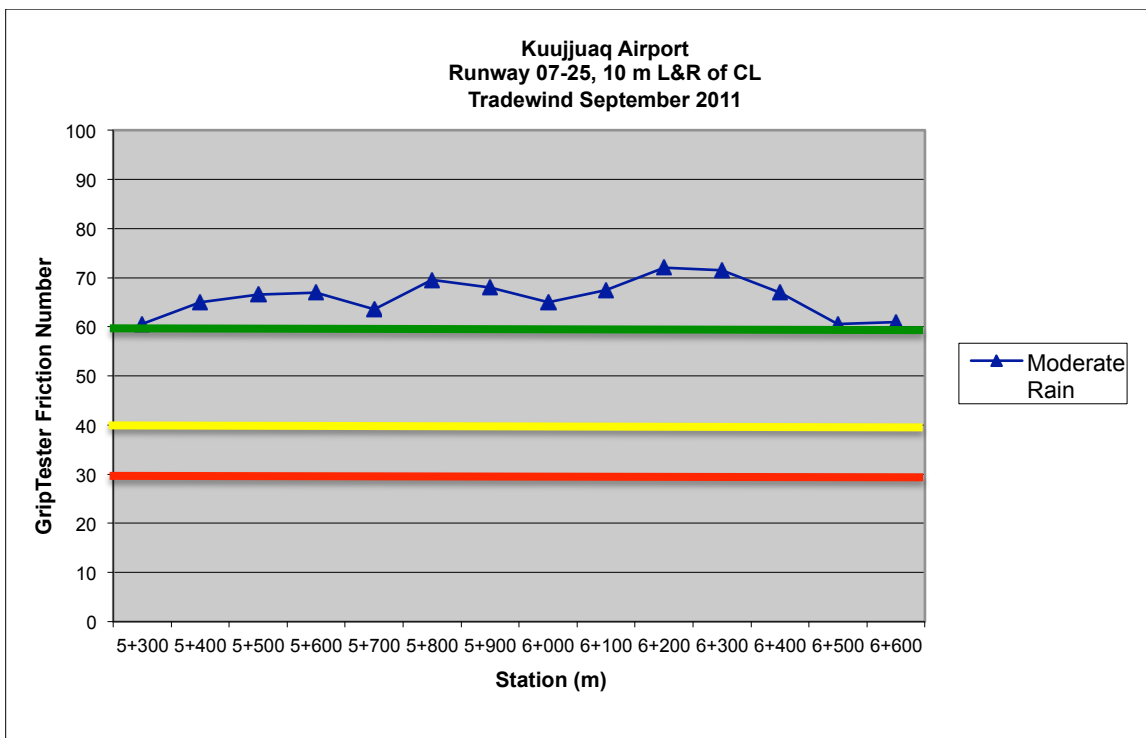

Figure A.36 2011 GripTester friction results, average of 10 m L&R offsets, moderate rain

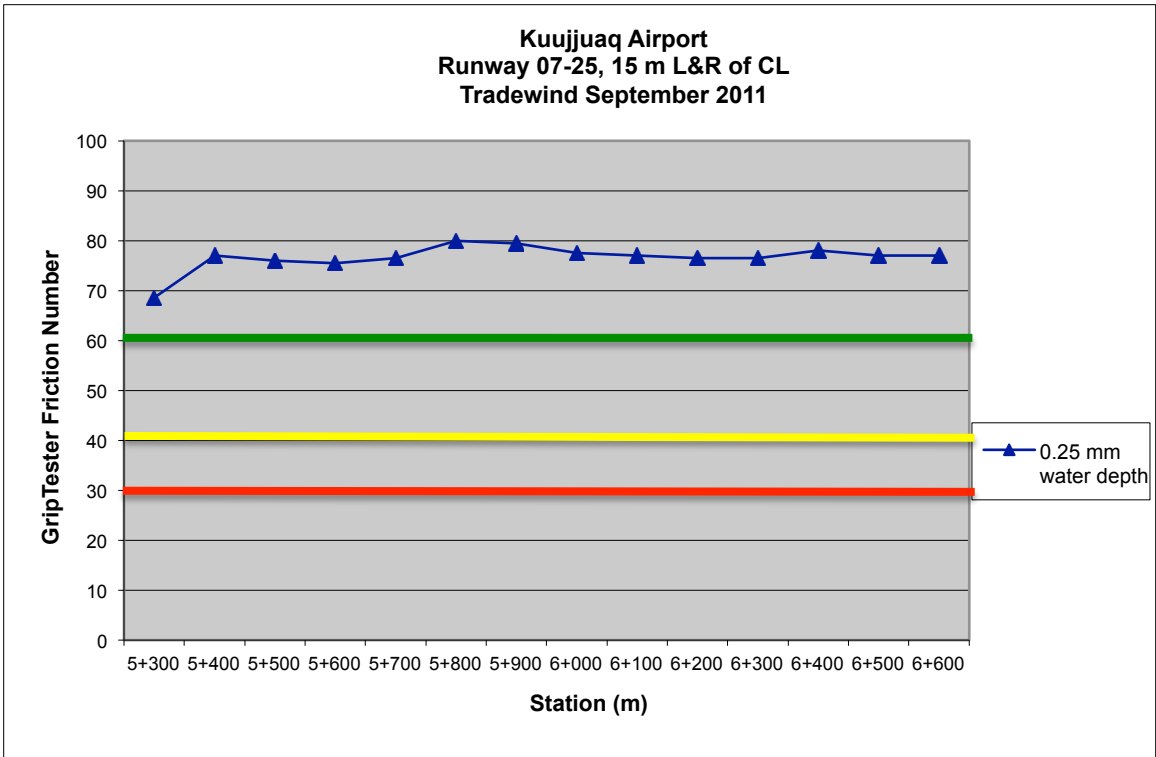

Figure A.37 2011 GripTester friction results, average of 15 m L&R offsets, 0.25 mm water depth

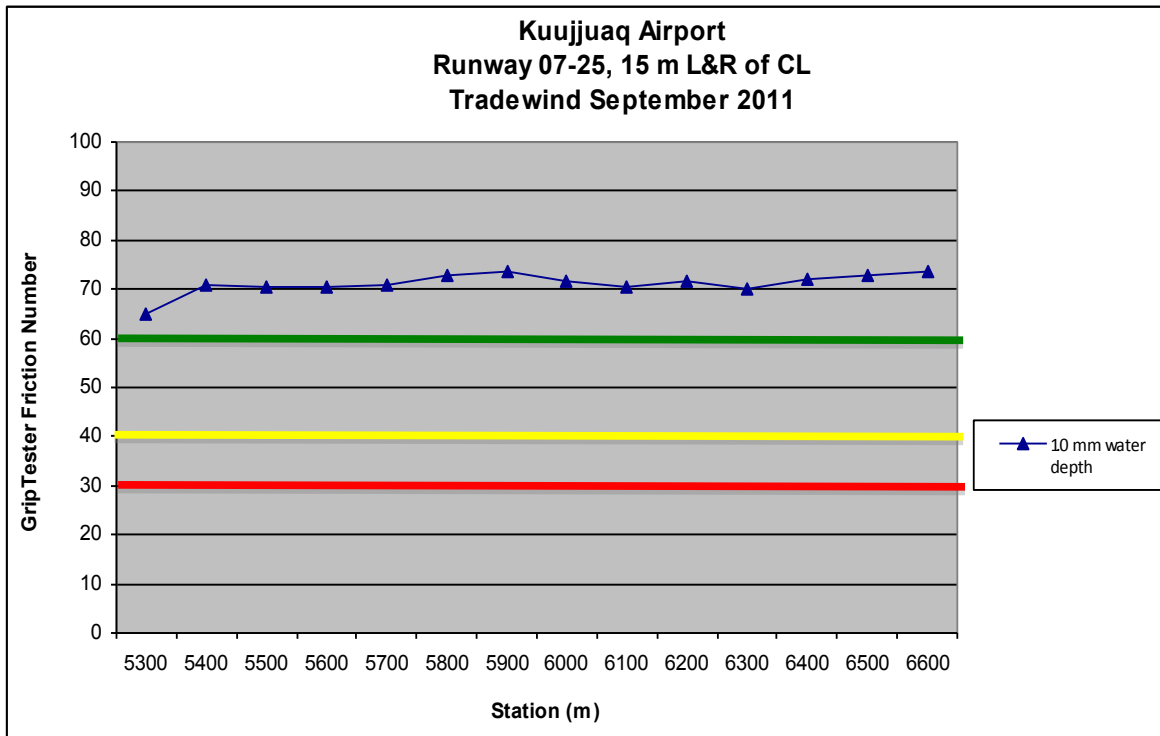

Figure A.38 2011 GripTester friction results, average of 15 m L&R offsets, 1.0 mm water depth

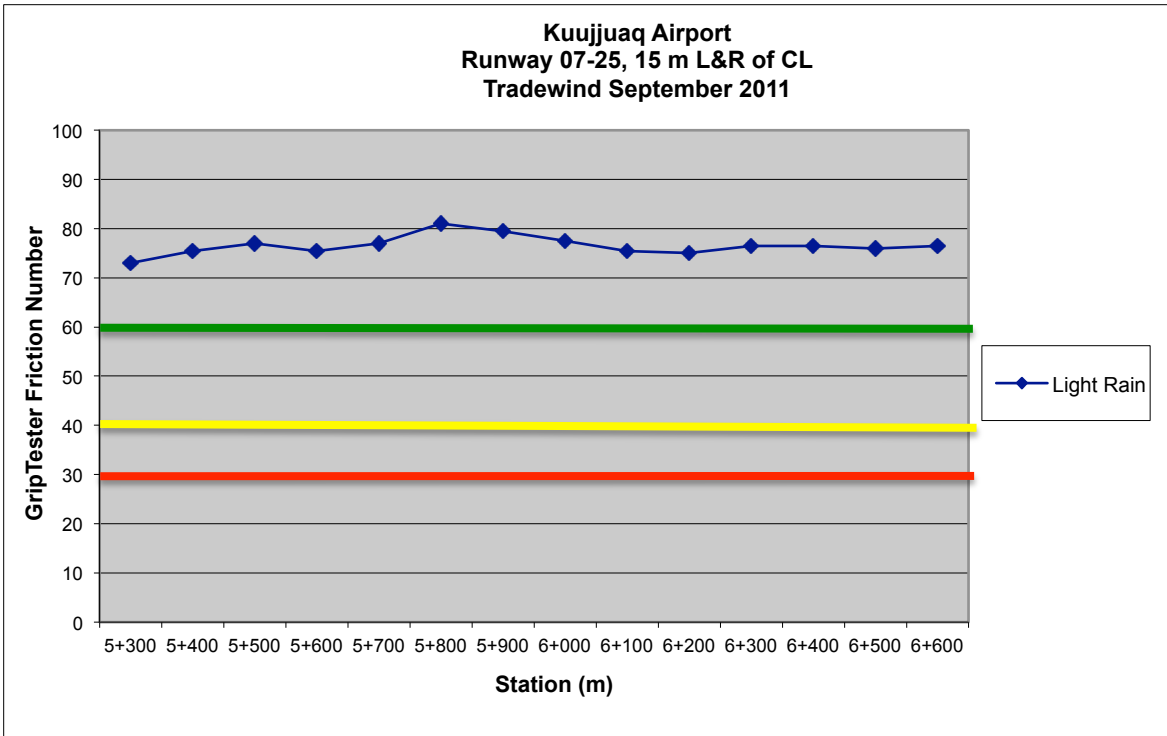

Figure A.39 2011 GripTester friction results, average of 15 m L&R offsets, light rain

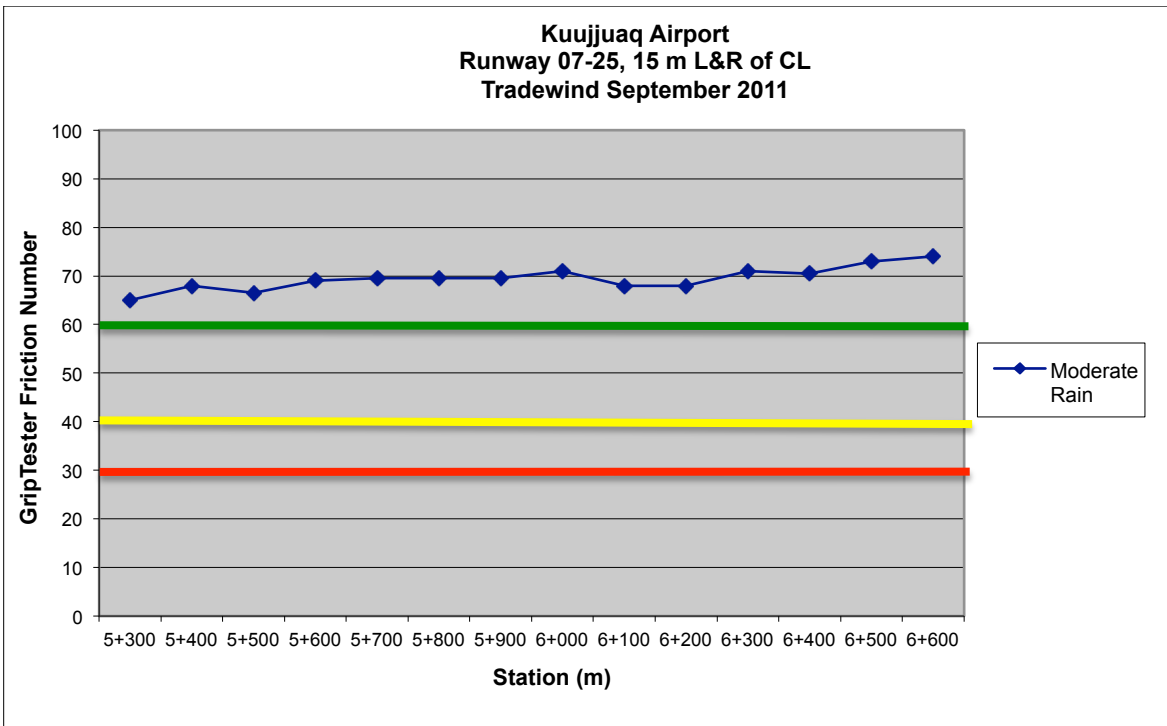
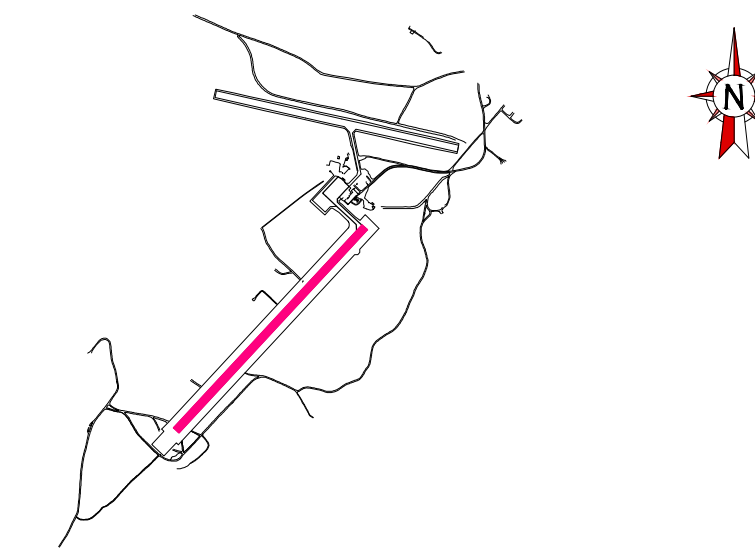

Figure A.40 2011 GripTester friction results, average of 15 m L&R offsets, moderate rain

Appendix B
Runway Texture and Friction Contour Maps with 2013 Data



LÉGENDE :

Profondeur moyenne de la macrotexture (mm)			
N°	MIN	MAX	Couleur
1	0.0	0.2	Orange
2	0.2	0.4	Rouge
3	0.4	0.8	Jaune
4	0.8	1.1	Vert clair
5	1.1	2.0	Vert foncé

Ce document doit être utilisé conjointement avec les recommandations formulées dans le rapport d'étude géotechnique.

NOTES :
1. RÉFÉRENCES : PLAN FOURNI PAR LE CLIENT, FICHER : VPCIV.dwg

BA	EMIS POUR COMMENTAIRES	L.C.	L.C.
13-495-20			
REV	A-M-J DATE	DESCRIPTION	Préparé Par
ÉMISSIONS / RÉVISIONS			
TOUTES LES DIMENSIONS DEVONT ÊTRE PRISES ET VÉRIFIÉES AVANT DE COMMENCER LES TRAVAUX			

Scenes

Client

Références du client

Projet

PROJET D'ADAPTATION DES INFRASTRUCTURES DE TRANSPORTS AUX CHANGEMENTS CLIMATIQUES

KULUJUAQ, QUÉBEC

Titre

RÉLEVÉS 2013
RÉSULTATS DES MESURES "TACHE DE SABLE"

Dessau-JNA Dessau-JNA

1800, rue University
Montréal (Québec) H3E 4Y3
Téléphone : 514 281 1010
Télécopieur : 514 281 1066

Préparé	L. Chartrand, ing.	Discipline	Gestion des chaussées
Dessiné	J. Gratton	Échelle	1 : 500
Vérifié	L. Chartrand, ing.	Date	2013-09-20
Chargé de projet		N° de séquence	
L. Chartrand, ing.		01 de 04	
Rev. n°	Projet	Op	Disc
024	B-0006813	1	CH
		D	0001
			0A

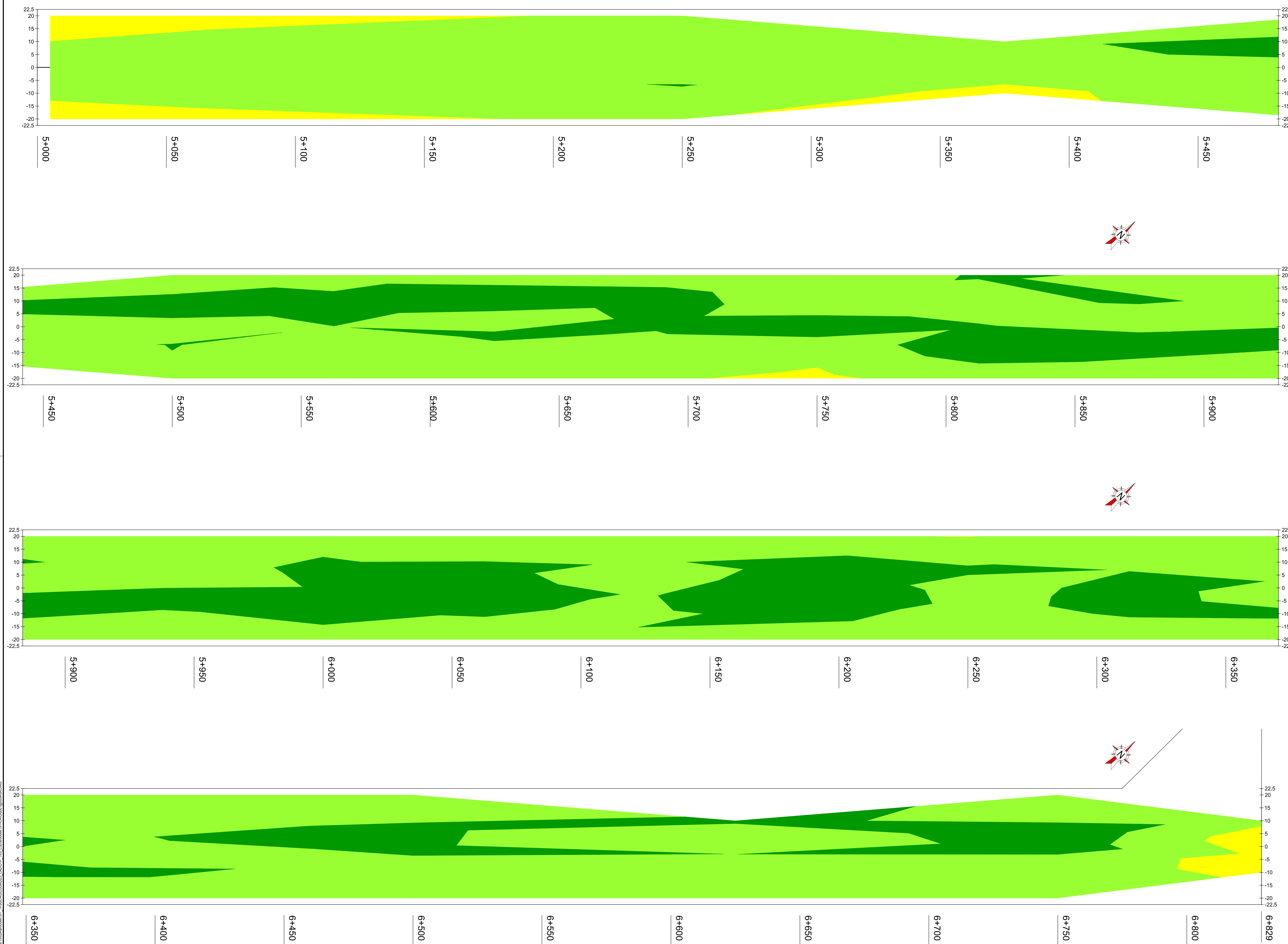

REVUE DE PROJET: 2013-09-20, C:\BIB\00013\CHOU\001\0004.dwg

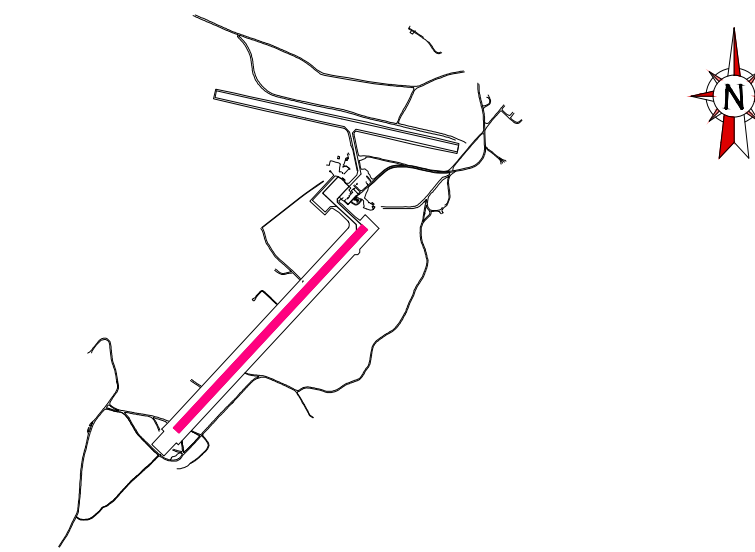

LÉGENDE :

Mean Texture Depth (mm)			
N°	MIN	MAX	Couleur
1	0.0	0.2	Dark Red
2	0.2	0.4	Orange
3	0.4	0.8	Yellow
4	0.8	1.1	Light Green
5	1.1	2.0	Dark Green

Ce document doit être utilisé conjointement avec les recommandations formulées dans le rapport d'étude géotechnique.

NOTES :
1. RÉFÉRENCES : PLAN FOURNI PAR LE CLIENT, FICHIER : VPCIV.dwg

BA	EMIS POUR COMMENTAIRES	L.C.	L.C.
13-495-20			
REV	A-M-J DATE	DESCRIPTION	Préparé Par / Vérifié Par

ÉMISSIONS / RÉVISIONS

TOUTES LES DIMENSIONS DEVONT ÊTRE PRISES ET VÉRIFIÉES AVANT DE COMMENCER LES TRAVAUX

Scenes

Client

Références du client

Projet

PROJET D'ADAPTATION DES INFRASTRUCTURES DE TRANSPORTS AUX CHANGEMENTS CLIMATIQUES

KULUJUAQ, QUÉBEC

Titre

RÉSULTATS DES MESURES "OUTFLOWMETER"

Dessau-JNA

Dessau-JNA
1800, rue University
Montréal (Québec) H3R 4V3
Téléphone : 514 281 1010
Télécopieur : 514 281 1066

Révisé par : L. Chartrand, ing. / Disciplinaire : Gestion des chaussées
 Dessiné par : J. Gratton / Échelle : 1 : 500
 Vérifié par : L. Chartrand, ing. / Date : 2013-09-20

Chargé de projet : L. Chartrand, ing. / N° de séquence : 02 dc 04

Srv.	req.	Projet	Op.	Disc.	Type	N° Dessin	Rév.
024	B-0006813	1	CH	D	0002	0A	



REVUE DE PROJET: 2013-09-20, C:\B\0006813\CH\0001\0004.dwg

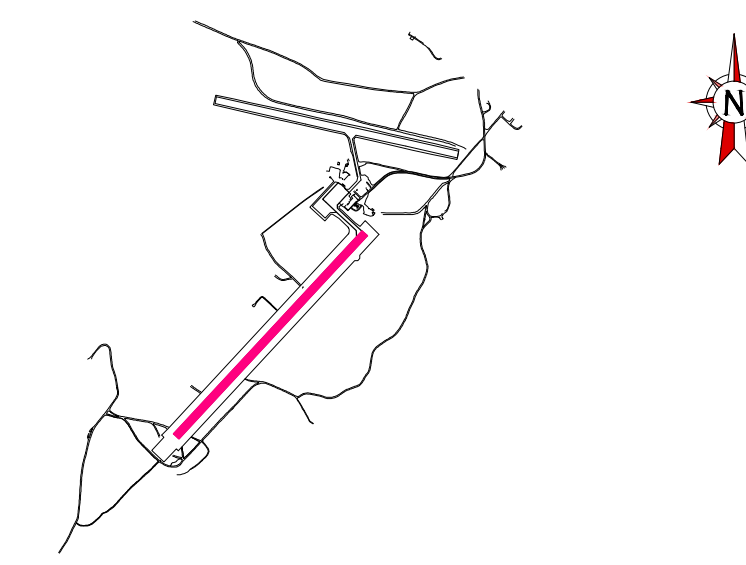

LÉGENDE :

Nombre du Pendule britannique (BPN) corrigé à 20°C			
N°	MIN	MAX	Couleur
1	0.0	65.0	Orange
2	65.0	70.0	Jaune
3	70.0	75.0	Vert clair
4	75.0	80.0	Vert moyen
5	80.0	100.0	Vert foncé

Ce document doit être utilisé conjointement avec les recommandations formulées dans le rapport d'étude géotechnique.

NOTES :
1. RÉFÉRENCES : PLAN FOURNI PAR LE CLIENT, FICHIER : VPCIV.dwg

BA	13-495-20	EMIS POUR COMMENTAIRES	L.C.	L.C.
REV	A - M - J	DATE	DESCRIPTION	Préparé Par Vérifié Par

ÉMISSIONS / RÉVISIONS

TOUTES LES DIMENSIONS DEVONT ÊTRE PRISES ET VÉRIFIÉES AVANT DE COMMENCER LES TRAVAUX

Scenes

Client

Travaux Publics et Services gouvernementaux Canada

Références du client

Projet

PROJET D'ADAPTATION DES INFRASTRUCTURES DE TRANSPORTS AUX CHANGEMENTS CLIMATIQUES

KULIJUAQ, QUÉBEC

Titre

**RELEVÉS 2013
RÉSULTATS DES MESURES "PENDULE BRITANNIQUE"**

Dessau-JNA

Dessau-JNA
1000, rue University
Montréal (Québec) H3B 4Y3
Téléphone : 514 281 1010
Télécopieur : 514 281 1060

Préparé L. Chartrand, ing. Discipline Gestion des chaussées
Dessiné J. Gratton Échelle 1 : 500
Vérifié L. Chartrand, ing. Date 2013-09-20

Chargé de projet L. Chartrand, ing. N° de séquence 03 dc 04

Rev.	N° Dessin	Type	Disc.	Org.	Projet	Rev.
024	B-0006813	1	CH	D	0003	0A

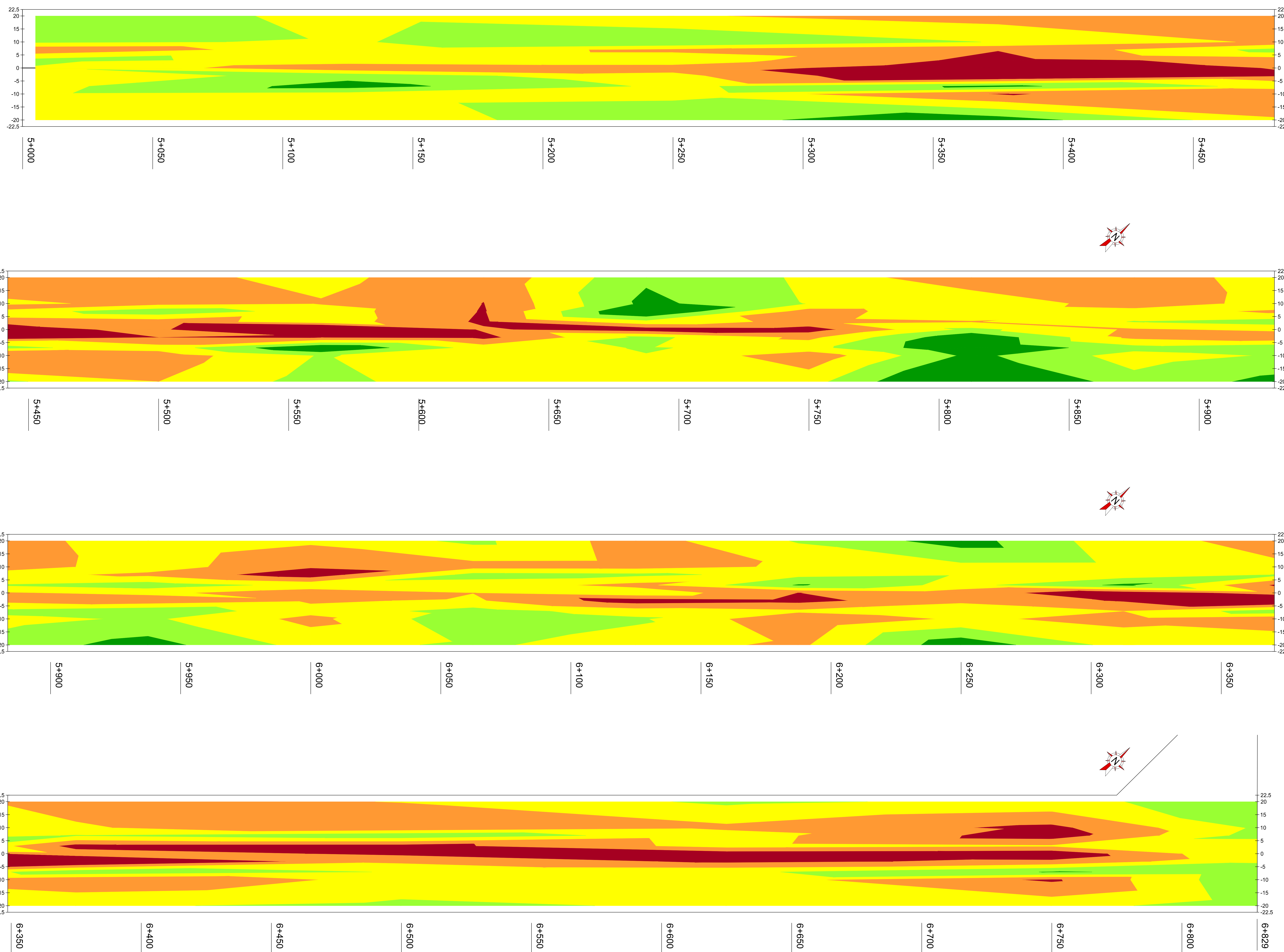

REVUE ET APPROUVÉ PAR LVM - PROJET: KULIJUAQ - CACDTP - 103 - CDR: 000013 - CHOUX - 01000.dwg

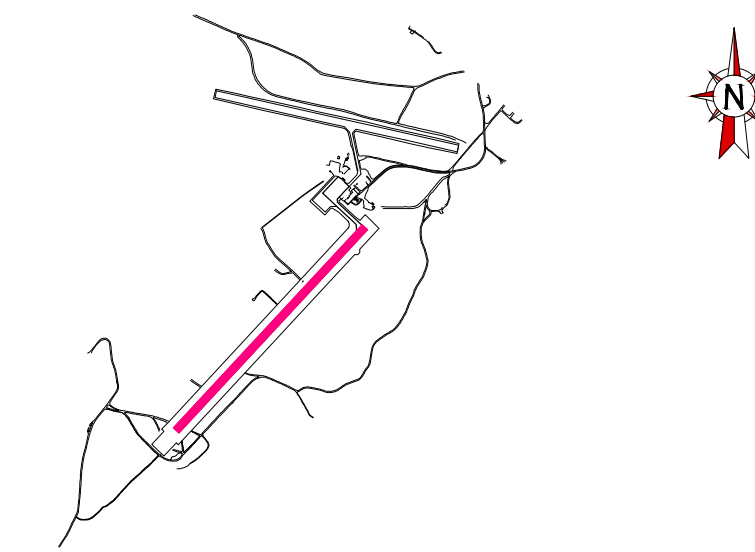

LÉGENDE :

Résultats "GripTester"			
N°	MIN	MAX	Couleur
1	0	30	Orange
2	30	40	Rouge
3	40	50	Jaune
4	50	60	Vert clair
5	60	90	Vert foncé

Ce document doit être utilisé conjointement avec les recommandations formulées dans le rapport d'étude géotechnique.

NOTES :
1. RÉFÉRENCES : PLAN FOURNI PAR LE CLIENT, FICHER : VPCIV.dwg

DA	13-12-02	EMIS POUR COMMENTAIRES	L.C.	L.C.	
REV	A-M-J	DATE	DESCRIPTION	Préparé Par	Vérifié Par
ÉMISSIONS / RÉVISIONS					
TOUTES LES DIMENSIONS DEVONT ÊTRE PRISES ET VÉRIFIÉES AVANT DE COMMENCER LES TRAVAUX					

Scenes

Client

Références du client

Projet

PROJET D'ADAPTATION DES INFRASTRUCTURES DE TRANSPORTS AUX CHANGEMENTS CLIMATIQUES

KULUJUAQ, QUÉBEC

Titre

RELEVÉS 2013 RÉSULTATS DES MESURES "GRIP TESTER" 0,25

Dessau-JNA Dessau-JNA

1800, rue University
Montréal (Québec) H3B 4Y3
Téléphone : 514 281 1010
Télécopieur : 514 281 1066

Préparé	L. Chartrand, ing.	Discipline	Gestion des chaussées
Dessiné	J. Gratton	Échelle	1 : 500
Vérifié	L. Chartrand, ing.	Date	2013-12-02
Chargé de projet		N° de séquence	
L. Chartrand, ing.		04 dc 06	
Proj. no	024	Projet	B-0006813
Op	1	Disc.	CH
Type	D	N° Dessin	0004
Rev.	0A		

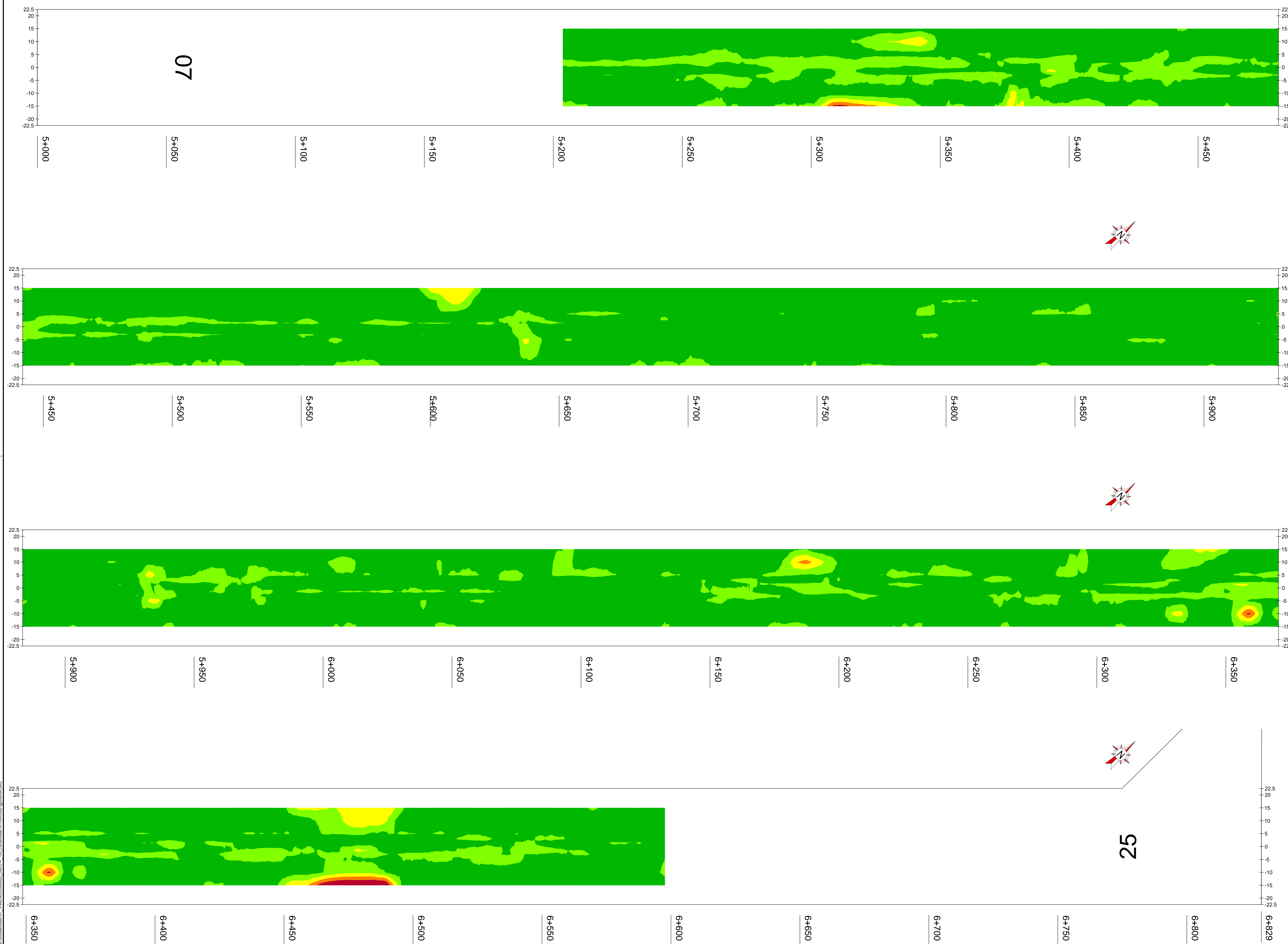

07

25

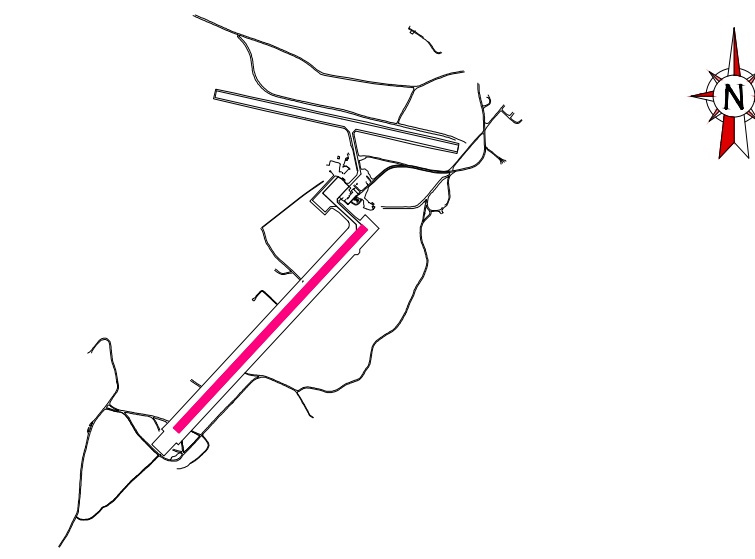

LÉGENDE :

Résultats "GripTester"			
N°	MIN	MAX	Couleur
1	0	30	Orange
2	30	40	Rouge
3	40	50	Jaune
4	50	60	Vert clair
5	60	90	Vert foncé

Ce document doit être utilisé conjointement avec les recommandations formulées dans le rapport d'étude géotechnique.

NOTES :
1. RÉFÉRENCES : PLAN FOURNI PAR LE CLIENT, FICHER : VPCIV.dwg

BA	13-12-02	EMIS POUR COMMENTAIRES	L.C.	L.C.
REV	A-M-J	DATE	Préparé	Vérifié
ÉMISSIONS / RÉVISIONS				
TOUTES LES DIMENSIONS DEVONT ÊTRE PRISES ET VÉRIFIÉES AVANT DE COMMENCER LES TRAVAUX				

Scenes

Client

Travaux Publics et Services gouvernementaux Canada

Références du client

Projet

PROJET D'ADAPTATION DES INFRASTRUCTURES DE TRANSPORTS AUX CHANGEMENTS CLIMATIQUES

KULUJUAQ, QUÉBEC

Titre

RELEVÉS 2013 RÉSULTATS DES MESURES "GRIP TESTER" 0,50

Dessau-JNA Dessau-JNA

1800, rue University
Montréal (Québec) H3B 4Y3
Téléphone : 514 281 1010
Télécopieur : 514 281 1066

Préparé	L. Chartrand, ing.	Discipline	Gestion des chaussées
Dessiné	J. Gratton	Échelle	1 : 500
Vérifié	L. Chartrand, ing.	Date	2013-12-02

Chargé de projet

L. Chartrand, ing. N° de séquence **05 dc 06**

Proj.	Projet	Op.	Disc.	Type	N° Dessin	Rév.
024	B-0006813	1	CH	D	0005	0A

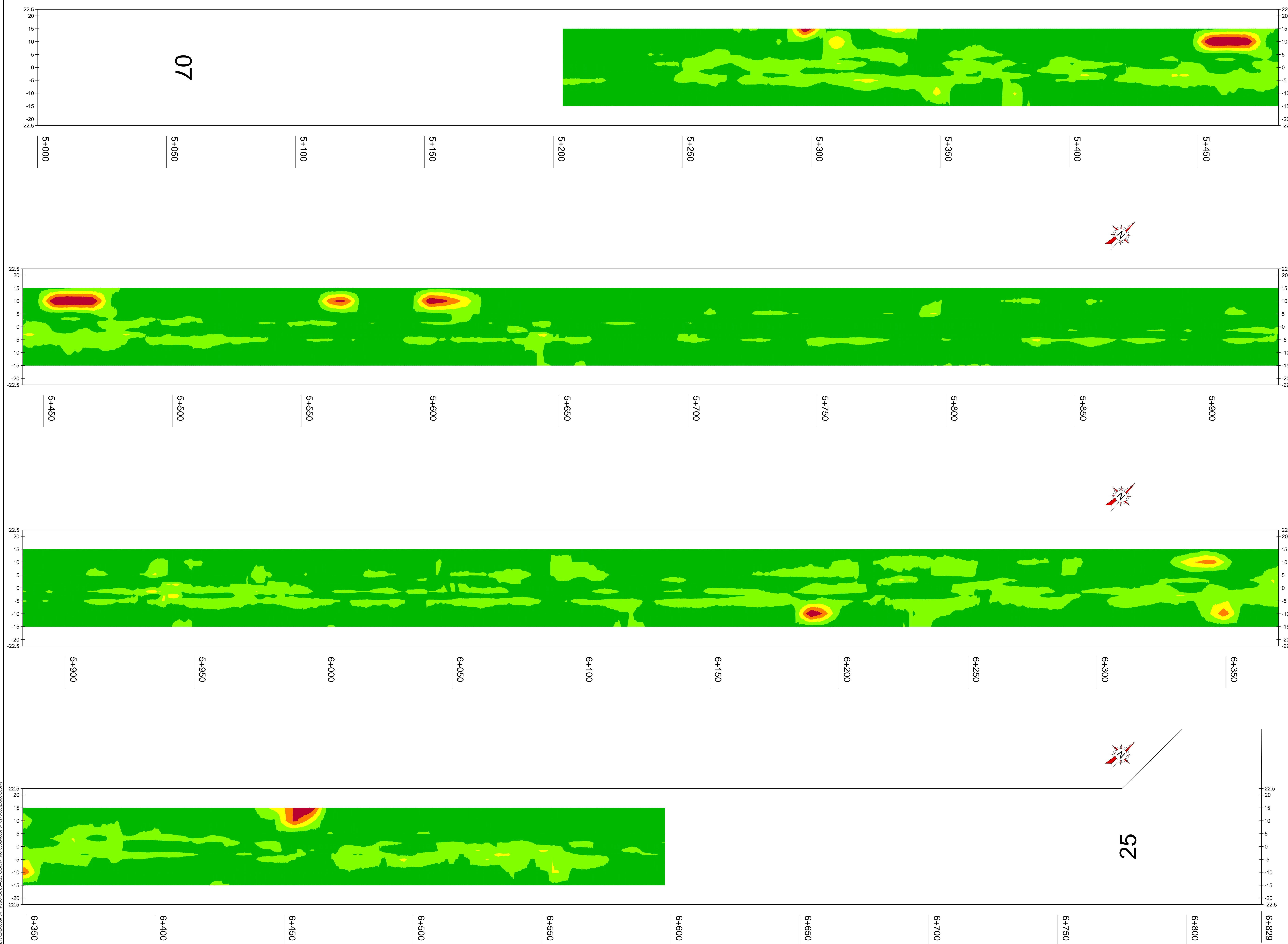

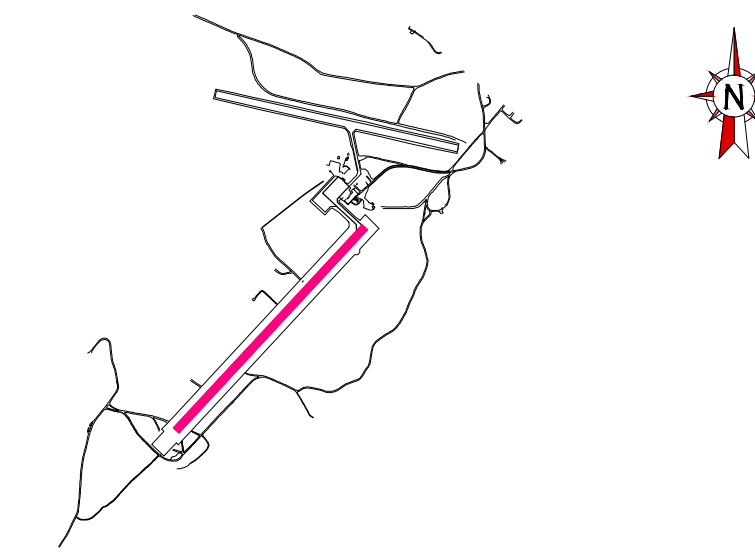

LÉGENDE :

Résultats "GripTester"			
N°	MIN	MAX	Couleur
1	0	30	
2	30	40	
3	40	50	
4	50	60	
5	60	90	

Ce document doit être utilisé conjointement avec les recommandations formulées dans le rapport d'étude géotechnique.

NOTES :
1. RÉFÉRENCES : PLAN FOURNI PAR LE CLIENT, FICHER : VPCIV.dwg

DA	13-12-02	EMIS POUR COMMENTAIRES	L.C.	L.C.	
REV	A-M-J	DATE	DESCRIPTION	Préparé Par	Vérifié Par
ÉMISSIONS / RÉVISIONS					
TOUTES LES DIMENSIONS DEVONT ÊTRE PRISES ET VÉRIFIÉES AVANT DE COMMENCER LES TRAVAUX					

Scenes

Client

Travaux Publics et Services gouvernementaux Canada

Références du client

Projet

PROJET D'ADAPTATION DES INFRASTRUCTURES DE TRANSPORTS AUX CHANGEMENTS CLIMATIQUES

KULUJUAQ, QUÉBEC

Titre

RELEVÉS 2013 RÉSULTATS DES MESURES "GRIP TESTER" 1,0

Dessau-JNA Dessau-JNA

1800, rue University
Montréal (Québec) H3B 4Y3
Téléphone : 514 281 1010
Télécopieur : 514 281 1066

Préparé	L. Chartrand, ing.	Discipline	Gestion des chaussées
Dessiné	J. Gratton	Échelle	1 : 500
Vérifié	L. Chartrand, ing.	Date	2013-12-02

Chargé de projet

L. Chartrand, ing. N° de séquence **06 dc 06**

Surv. exp.	Projet	Op.	Disc.	Type	N° Dessin	Rev.
024	B-0006813	1	CH	D	0006	0A

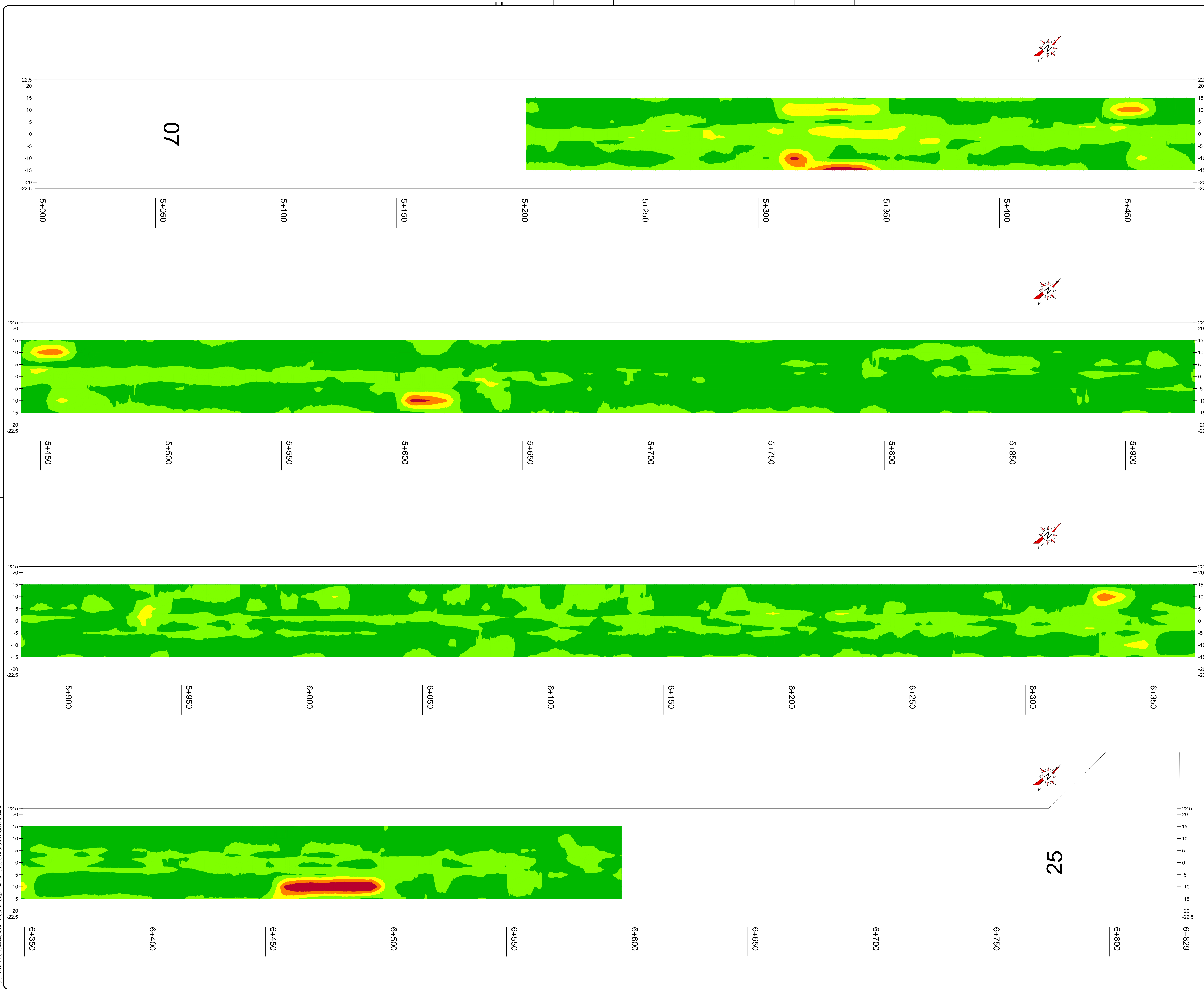

Appendix C
FWD Contour Map with 2010 Data

CE DOCUMENT D'INGÉNÉRIE EST L'ŒUVRE DE LVM ET EST PROTÉGÉ PAR LA LOI. IL EST DESTINÉ EXCLUSIVEMENT AUX FINS QUI Y SONT MENTIONNÉES. TOUTE REPRODUCTION OU ADAPTATION, PARTIELLE OU TOTALE, EN EST STRICTEMENT PROHIBÉ SANS AVOIR PRÉALABLEMENT OBTENU L'AUTORISATION ÉCRITE DE LVM.

LÉGENDE :

MODULE DE RIGIDITÉ (kN/mm)			
No.	MINIMUM	MAXIMUM	COULEUR
1	50.0	80.0	■
2	80.0	110.0	■
3	110.0	140.0	■
4	140.0	170.0	■
5	170.0	200.0	■

Ce document doit être utilisé conjointement avec les recommandations formulées dans le rapport d'étude géotechnique

NOTES :
1. RÉFÉRENCES : PLAN FOURNI PAR LE CLIENT.
FICHER:VPCIV.dwg

REV.	A-M-J	DATE	DESCRIPTION	Préparé Par	Vérifié Par
00	11-03-08		ÉMISSION POUR COMMENTAIRES	L.C.	N.M.
ÉMISSIONS / RÉVISIONS					
TOUTES LES DIMENSIONS DEVONT ÊTRE PRISES ET VÉRIFIÉES AVANT DE COMMENCER LES TRAVAUX.					

PRÉLIMINAIRE

Client
 Travaux Publics et Services gouvernementaux Canada

Références du client

Projet
ÉVALUATION DE LA CAPACITÉ PORTANTE ET DE L'ÉTAT DE SURFACE DE LA PISTE 07-25
KULURUQ, QUÉBEC

Titre
CAPACITÉ PORTANTE SEPTEMBRE 2010

LVM inc. 85, rue J.-A. Bombardier, Bureau 100
Brossard, Québec J4B 0T4
Téléphone : 450-441-1740
Télécopieur : 450-449-0235

Préparé par: **L. Chartrand, Ing.** Discipline: **GESTION DE CHAUSSEES**
 Dessiné par: **J. Gratton** Echelle: **1 : 500**
 Vérifié par: **N. Martel, Ing., M.Sc.** Date: **2011-03-08**

Chargé de projet: **L. Chartrand, Ing.** N° de séquence: **01 de 01**

Serv. maître: **025 P036338 0170** Proj. Lot: **CH D002 00** Disc. N° Exéc. Rév.

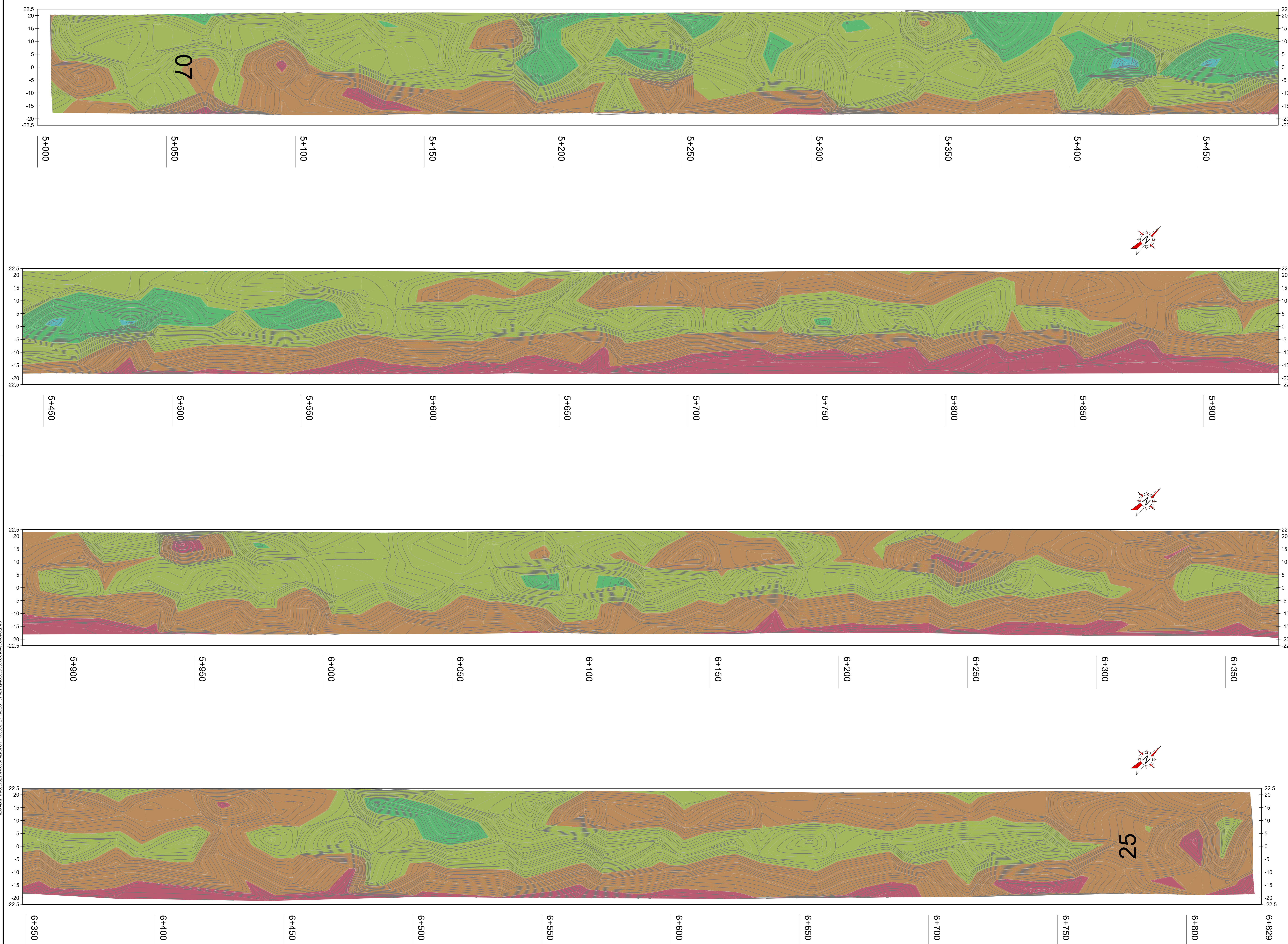

025 P036338 0170
 LVM inc.
 85, rue J.-A. Bombardier, Bureau 100
 Brossard, Québec J4B 0T4
 Téléphone : 450-441-1740
 Télécopieur : 450-449-0235