

Brick

a story of construction

by
Samantha Oswald

A thesis
presented to the University of Waterloo
in fulfilment of the
thesis requirement for the degree of
Master of Architecture

Waterloo, Ontario, Canada 2013

© Samantha Oswald 2013

AUTHOR'S DECLARATION |

I hereby declare that I am the sole author of this thesis. This is a true copy of the thesis, including any required final revisions as accepted by my examiners.

I understand that my thesis may be made electronically available to the public.

Brick. A simple object, but one that has been a base unit of architecture for over 6000 years. It carries connotations of labour, of energy, of the fundamental desire of humanity to give form to the substance of the Earth. However, current tendencies in manufacturing and construction are challenging the prevalence of the traditional brick-and-mortar system. Automated manufacturing, large-scale prefabrication, and digital simulation are becoming standard practices. This thesis posits that although brick must adapt to a changing architectural climate, contemporary construction should also learn from the versatility and poetics of this timeless material. Starting from clay, I make and inhabit a shelter of brick. My interaction with the material serves as grounding for a wider discussion of its role in architecture today.

ACKNOWLEDGEMENTS |

Profound thanks to my supervisor, Anne Bordeleau, for her confidence in my work, and in the potential of brick as a thesis topic. Cheers to Guan Lee and the Grymsdyke Farm community, for their generosity, advice, and moral support. Especially to Guan - I cannot thank you enough for letting me share your home, your workshop, your ideas, and your vision. Thanks to John Straube for his reality checks and wise input.

I am grateful to the people who have helped me with my research:

Grazie to the Fornace Bernasconi, for showing me the poetics of brick.

Dziękuję to the employees of the Historical Museum of Warsaw, for helping me untangle Warsaw's history.

Thanks to Patrick Kelly and Hanson brick for a fascinating introduction to large-scale brick manufacturing.

Thanks to those who edited my text and layout.

Thanks to Virginia, for being there, even when you weren't.

And to all my friends and family, my friends who are like family: you mean so much to me. Thanks for everything.

TABLE OF CONTENTS |

List of Illustrations	vi
Introduction	1
Clay	6
Forming	22
Firing	44
Assembly	64
Performance	82
(Dis)Association	98
Inhabitation	116
Conclusion	134
Endnotes	136
Bibliography	142
Appendix: Video	146

LIST OF ILLUSTRATIONS | All images by author.

<i>Page</i>		<i>Description</i>	<i>Page</i>		<i>Description</i>
INTRODUCTION					
1	i	Raw clay at Grymsdyke Farm.	16	1.15	Spline drawn in Rhino.
3	ii	The Terracott under construction.	17	1.16	Freshly dug clay.
5	iii	Wall 1 under construction.	18	1.17	Brick cracks.
CLAY					
6-7	1.1	Grymsdyke Farm clay on a misty morning	19	1.18	A Grasshopper program to parametrically create the solid shape of mortar between two bricks at different angles.
8	1.2	Clay — the ideal substance?	21	1.19	Clay too sticky for molding is dried on boards.
10	1.3	The molecular structure of kaolinite, a common clay mineral.	FORMING		
11	1.4	Clay at Grymsdyke Farm.	22-23	2.1	Bricks drying in the warehouse in Castel Viscardo.
12	1.5	Soaking.	24	2.2	At Fornace Bernasconi in Castel Viscardo, Italy, each brick is hand-formed in a metal mold.
12	1.6	Mixing.	25	2.3	The fired bricks.
12	1.7	Settling.		2.4	These bricks clearly bear the marks of their extrusion.
12	1.8	Sorting.	26		
13	1.9	Spreading.	27	2.5	Brick-drying shed, Radzymin, Poland.
13	1.10	Mixing.	29	2.6	A rotating stamp in the brick factory in Aldershot.
13	1.11	Drying.	30	2.7	“Hand-made”?
13	1.12	Cracking.	31	2.8	The factory in Burlington produces bricks that are shipped all over North America.
14	1.13	Exhaustion.	33	2.9	Hand-formed Buckinghamshire brick.
15	1.14	“Puddling”— mixing clay with sand.			

<i>Page</i>	<i>Description</i>	<i>Page</i>	<i>Description</i>
33	2.10 Metal brick molds.	50	3.5 Diagram of an updraught kiln Reference: Danilo Casagrande, e-mail to Samantha Oswald, May 27, 2013
33	2.11 Traditional brick forming.		
33	2.12 Collection of special molds.		
34	2.13 The first mold was fabricated in two pieces using the CNC router and subsequently assembled.	51	3.6 View into an updraught kiln, Castel Viscardo, Italy.
		52	3.7 Diagram of a Hoffman kiln Reference: R.G. Smith and M. Allal, <i>Small-Scale Brickmaking</i> , accessed June 29, 2013, http://collections.infocollections.org/ukedu/uk/d/Jh2385e/2.html
35	2.14 Traditional brickwork of Buckinghamshire: The Cottage at Grymsdyke Farm.		
36-37	2.15 The forming process.		
38	2.16 The finished brick.	53	3.8 Top level of a Hoffman kiln, Radzymin, Poland
39	2.17 In the first mold I made, the inside corners were rounded from the radius of the CNC drill bit.	54	3.9 Diagram of a tunnel kiln Reference: Jack Hewitt (Project & Environmental Manager, Hanson Brick), e-mail to Samantha Oswald, July 22, 2013
39	2.18 The second mold was made from four pieces assembled into two angles and held in place by a retaining ring.	55	3.10 A modern tunnel kiln, Burlington, Ontario.
39	2.19 Pattern and cast: a test of sand-casting aluminum.	56	3.11 Diagram of a vertical shaft kiln Reference: Urs Heierli, "The Most Energy Efficient Brick Kiln", Swiss Agency for Development and Cooperation, accessed May 15, 2013, http://www.poverty.ch/asian-brickindustry/energy-efficient-kiln.html
40	2.20 The rows of sand support the drying bricks from underneath.		
40	2.21 The drying racks.		
41	2.22 Creases.		
43	2.23 Rethinking the tradition: the Grymsdyke brick experiments inhabit the old brick farmhouse.	57	3.12 Diagram of Grymsdyke Kiln
		59	3.13 Kiln unloading, Grymsdyke Farm.
		60	3.14 Kiln stacking, Grymsdyke Farm.
		61	3.15 Stacking for storage after firing.
		62	3.16 Sand traces left in the kiln.
		63	3.17 Brick loading.
FIRING		ASSEMBLY	
44-45	3.1 Fire in the Terracott	64-65	4.1 The assemblies of the Terracott.
46	3.2 Baking tiles, Grymsdyke Farm.	66	4.2 A brick chipped to fit an acute corner.
47	3.3 Bricks stacked in an updraught kiln, Castel Viscardo, Italy		
49	3.4 Kiln cars loaded for firing in a tunnel kiln, Burlington, Ontario.		

<i>Page</i>	<i>Description</i>
67	4.3 Some proprietary masonry systems. References: “Novabrik Self-Ventilating Mortarless Brick Siding,” accessed June 29, 2013, http://www.novabrik.com/html/en_stage/accueil/index.php3?flash=2 “Interlocking Soil-Cement Brick Technology”, Habitech Centre, accessed June 22, 2013, http://www.unicef.org/education/files/Interlocking_Earth_Bricks_technology.pdf “The Flexlock Wall System”, Cercorp Initiatives Inc., accessed June 22, 2013, http://www.cercorp.com/#!/_flexlock “Porotherm Installation Brochure”, Wienerberger, accessed June 22, 2013, http://www.wienerberger.co.uk/walls/blocks/literature/download-brochure/-view-online/porotherm-installation.html?lpi=1313012152978
69	4.4 The first courses of bricks of the Terracott.
71	4.5 Mortar is used to accommodate changes in material.
71	4.6 The Vatican Wall system easily accepts anomalies.
73	4.7 Wall laid by the ROB robot.
75	4.8 Assemblies used in the Terracott.
76	4.9 Pouring the slab.
76	4.10 Design for a mortar mold.
77	4.11 Joint finishing.
78	4.12 The bricklayer demonstrates the proper consistency for mortar.
79	4.13 Roof mortaring.
80	4.14 Interlocking assemblies used for the floor of the Terracott.
81	4.15 A Wall 2 joint.

<i>Page</i>	<i>Description</i>
PERFORMANCE	
82-83	5.1 Wall 1 of the Terracott, absorbing sunlight.
84	5.2 Overlapping tiles create a Catalan vault.
85	5.3 The Catalan vault at Grymsdyke Farm.
87	5.4 Screenshot from the RhinoVault catenary vault modelling plugin.
89	5.5 A Wienerberger Porotherm block.
90	5.6 The brick designed by Alvar Aalto for the House of Culture in Helsinki. Reference: “Press Release: Alvar Aalto through the Eyes of Shigeru Ban”, Alvar Aalto Museum, published February 15, 2007, accessed July 19, 2013, http://www.alvaraalto.fi/info/press/07eng_barbican.htm
91	5.7 The sun-filtering screen of the Gantenbein winery.
93	5.8 The Gantenbein winery facade patterns.
94	5.9 The chosen module.
95	5.10 3d printed module iterations.
96	5.11 The bricks are assembled to create a permeable screen.
(DIS)ASSOCIATION	
98-99	6.1 Brick replacement work at Fort Legionów, Warsaw
101	6.2 Ulica Waliców 14. I revisited this abandoned tenement often.
102	6.3 The Old Town Wall, Warsaw.
103	6.4 Plac Zamkowy, the main square at the entrance to Warsaw’s Old Town.
105	6.5 Statue of a bricklayer on a Social Realist building.
106	6.6 Provisional solutions to crumbling brick.
107	6.7 Demolitions, Koneser factory.
108	6.8 A fragment of crushed-brick concrete from the Muranów district

<i>Page</i>	<i>Description</i>
109	6.9 Warsaw's red underbelly.
110	6.10 Brick sculpted in metal at the Monument to the Warsaw Uprising.
111	6.11 Graffiti with a brick backdrop.
112	6.12 Porotherm blocks.
113	6.13 Bricks removed from the Jewish Ghetto wall are placed in museums around the world.
115	6.14 "Stone and What": Mural at Ulica Waliców 14

INHABITATION

116-117	7.1 Hay bales in the field.
120	7.2 Fire in the Terracott.
121	7.3 Sleeping surface.
122	7.4 Site Plan.
123	7.5 Looking back towards the main house.
124	7.6 Smoke drifting from the chimney.
125	7.7 Plan.
126	7.8 Section A.
127	7.9 Sunlight through Wall 1
128	7.10 The sun rises almost directly in line with the opening.
129	7.11 Section B.
130	7.12 Waiting out the rain.
131	7.13 Sunrise.
132-133	7.14 Sunset.



This book is about brick, but it is also about construction. It is about the physical and philosophical challenges of transforming raw material into habitable space. I worked through the entire process, from material extraction to inhabitation, and the issues I had to face during that journey were the same ones facing not only brick construction but the construction industry as a whole. Normally, the processes of material transformation that enable the construction of buildings are ignored or accepted as convention due to their complex logistics and large investments in machinery. Personal experience reveals the tangible reality of these hidden processes, exposing their difficulties and potentials. The full environmental and cultural impacts of construction can be understood only by considering the entire life cycle of material.

A brick is a fired clay masonry module of dimensions that can be handled by one worker. It is also much more than that. Brick is embedded in our cultural consciousness as one of the fundamental symbols of architecture. No other material has such an extensive history, widespread application, and depth of association. However, building with brick also foregrounds questions regarding the value of human labour, the meaning of craft, even the relevance of permanent construction in our increasingly transient society.

A studio term in Rome, Italy, and a personal fascination with Warsaw, Poland, led me to extensive investigations of brick in those two places. I visited brick manufacturing operations near those cities as well as in Chesham, UK, and Burlington, Ontario. These varied studies culminated in the fabrication of bricks and the construction of a single-occupant brick shelter at Grymsdyke Farm in Lacey Green, UK. The unique set of resources available at the farm – its clay soil, extensive digital fabrication and workshop equipment, and community of makers – provided an ideal environment for experimentation. Formerly an agricultural property, Grymsdyke Farm was purchased in 2004 by founders Guan Lee and Paul Starr with an intent to test an alternative model of architectural practice and education. Its facilities have grown to include a full wood workshop, kiln, laser cutter, 3d printer, and CNC router. The emphasis on craft and material investigation references the farm's situation in the county of Buckinghamshire, famous for its history of manufacturing operations that included furniture, cabinets, and ceramics. Past projects at Grymsdyke Farm have drawn from its heritage as well as concerns in current architectural research. The results of tests in concrete, plaster, and milled wood are found all across the site. The shelter, which I have named the Terracott, extends these themes into the matter of brick.



The chapters of this book are structured according to the processes that produced the Terracott. Each relates a phase in the life of a brick to a issue in contemporary construction. Part 1, Clay, examines the nature of humanity's plastic imagination and its manifestation in virtual media. Part 2, Forming, addresses the legibility of manufacturing processes in constructed objects. Part 3, Firing, attempts to define 'embodied energy' in a way that is not purely quantitative. Part 4, Assembly, questions the issue of tolerance. Part 5, Performance, looks at the current trend of performative architecture and the shift towards low-tech, passive solutions. Part 6, (Dis)association, discusses the relationship between materials and their meaning, taking the city of Warsaw as a case study. Part 7, Inhabitation, concludes with a reflection on my experience in the Terracott.

The questions that underlie these investigations are: what can contemporary construction learn from brick? And, what can brick learn from contemporary construction? This pairing positions architecture as the product of physical operations, both at the scale of the individual designer and at the scale of industry. By engaging with these operations, we can affirm that brick is not governed solely by the nostalgia for earth and fire nor solely by the economy of mass-production. Instead, it provides a fertile basis for the exploration of new relationships between hand, machine, and material.







For in order to create, some kind of clay is always needed, some plastic matter, some ambiguous matter in which earth and water can come together and unite. – Gaston Bachelard¹

In *Water and Dreams*, Gaston Bachelard states that working with clay is an intimate and vital reverie, one that is profoundly embedded in humanity’s subconscious material imagination. This desire to sculpt in plastic matter has been expressed architecturally in various media throughout history, most recently in the propensity for freeform digital modelling. Clay and virtual space can both seem like ideal substances that respond infinitely and plially to the will of the designer. In reality, both are controlled by the nature of their constituent particles. Both require continuous input – one of energy, the other of information – to retain their fluidity and coherence.

Both ancient Greek and Judeo-Christian creation myths describe man as being formed from clay. Book 1 of Ovid’s *Metamorphoses* reads:

*So Man was born, it may be, in God’s image,
Or Earth perhaps, so newly separated
From the old fire of Heaven, still retained*

*Some seed of the celestial force which fashioned
Gods out of living clay and running water.²*

1.2. Clay — the ideal substance?

These qualities conferred upon humans- formed in the image of God, made from earth- are repeated in the book of Genesis in the Bible:

And now, from the clay of the ground, the Lord God formed man, breathed into his nostrils the breath of life, and made of man a living person.³

Thus, mythically, human beings are made of clay, but they also have that spark of divinity that inspires them to test their own creative will on other matter. In both these examples, however, the truly god-like capacity exists not in the forming but in the ability to control the *life* of the material. The makers must acknowledge the changeable properties of the basic substance and harness them for their own purposes.

The complications of mutable materials are addressed by Gilbert Simondon.⁴ Writing about the genesis of objects, Simondon focuses on the technical operations that unite an abstract matter and an



ideal form as conceived by a maker. Using a brick as an example, he explains how both the substance and the mold must be prepared to receive this union. Simondon introduces a necessary third concept to the duality of form and matter, that of energy. In the most direct process, this energy is supplied by the same maker that holds the ideal form in mind. Then, the execution is straightforward; the mold must be made to a certain shape. The clay must be worked to obtain a homogenous and consistent substance that can take the form of the mold and retain it without distortion. Energy must be applied to push the clay into the mold so that it fills it completely. The order and purpose of these operations are easily intuited by the material imagination; however, their implementation is not so easy. Every shovelful of raw clay extracted, every bucket of clay mixed, every handful rolled in sand requires the physical investment of the worker.

The behaviour of clay is conditioned by the substance's relationship with water. There are two forms of water contained within clay: adsorbed water, which can evaporate, and chemically bound water, which is only driven out at temperatures above 350°. An adsorbed solution of water and metal ions holds the clay particles together. The small size of the particles increases the surface area available for this adhesion. The material can accept and retain shape because of

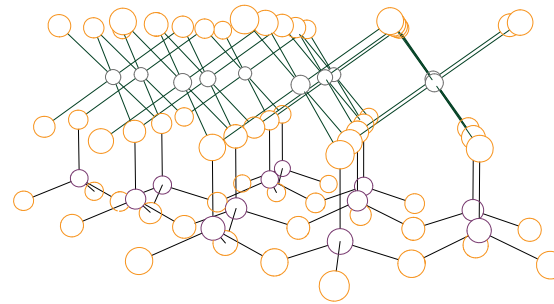

this interaction; the fluidity of water allows the particles to slip past each other, and its surface tension binds them together. The ions in the solution are constantly being exchanged with ones attached to the clay crystal.⁶ Clay is not inert but is in a state of dynamic equilibrium, its surface continuously dissolved and recrystallized.⁷

The small particle size that is responsible for clay's water-retentive properties is also the cause of a sluggish and uneven response to water in the substance. If a bucket of freshly dug clay is soaked in water overnight, the smaller clods will disintegrate or become fully saturated, while the larger clods resist permeation. As it dries, the differential shrinkage between the surface of a piece of clay and

1.3. The molecular structure of kaolinite, a common clay mineral. The silicon atoms (violet) are bound into tetrahedrons with oxygen atoms (orange). This forms a planar layer. One oxygen atom of each tetrahedron is shared with an octohedron that has an atom of aluminum (grey) at its centre. This is the second planar layer. These tetrahedrons and octohedrons are actually one of the simplest and most stable states for these elements.



1.4. Clay at Grymsdyke Farm.

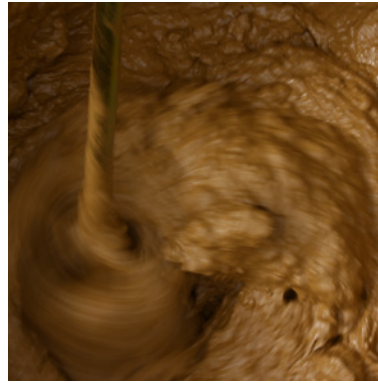

the thickness underneath will cause this surface layer to crack. This shrinkage is caused by the loss of water molecules and consequent reduction of the interstitial gap. Below a certain moisture content, clay is no longer plastic. When it cannot be rolled into threads of a diameter of 1/3 of a centimetre, it is said to have reached its plastic limit.⁸ Conversely, as more water is added, it reaches its 'liquid limit', at which its behaviour changes to that of a liquid. The particles remain in suspension and often take a day or more to settle in still water. Retaining the plasticity that is clay's remarkable trait demands the constant application of consolidating forces – hands, feet, pugmills – and knowledge of its interaction with water.

The clay at Grymsdyke Farm is characterized by its marriage with flint. The clay itself is yellow-brown, streaked with red, grey, and black, becoming a uniform ochre yellow when mixed with water. This substance wraps itself around the bone-white flint, which is often chipped to reveal a purple, translucent interior. To separate the flint from the clay, I added water and mixed it to make a thick suspension, then passed this mixture through a sieve. The hardest part of the process was drying the sieved clay, given the propensity of English weather to pour rain intermittently. I set up a shelter with

The multiple states of clay.

Left to right:

I.5. Soaking.

I.6. Mixing.

I.7. Settling.

I.8. Sorting.

I.9. Spreading.

I.10. Mixing.

I.11. Drying.

I.12. Cracking.



a tarp roof, which reduced the amount of air flow and slowed down the drying, but prevented loss by washout. The drying clay, spread on boards, had to be regularly turned; otherwise it would develop a hard crust under which it would still be too wet. Often, I would forget and the hard layer would have to be resoaked. I also relied on the force of my feet to homogenize the clay at different stages of drying. Clay saturated my life. It clung to my skin and clothes and took all the energy I had.

During those days, the free space of the computer screen was a welcome relief. The brick forms as I was designing them could be manipulated with the click of the mouse and could be deleted without a trace. They did not change if I left them, and did not have the constraints of physics or chemistry. This suggests that the virtual world had less limits and was more suited to my imaginings. I was frustrated, though, by the necessity of reducing the dimensions of the modelled object in order to change it. Working directly in 3D quickly increased the number of points needed to define the object, and reduced its manageability. Instead, the shape had to be projected onto a plane, one curve taken and modified, and then re-extruded. The digital world was still conditioned by basic laws arising from its underlying nature.



I.13. Exhaustion.

I.14. (opposite)

“Puddling” — mixing clay with sand.

Every form produced or represented digitally is the outcome of mathematical operations that define the coordinates of its boundaries. These coordinates can be generated either through splines or polylines; most modelling software supports both. In all cases, complex geometry is subdivided into sections. Each section of a spline is defined by an equation that identifies “points of influence” and a vector that governs how one piece will be related to the next.⁹ These points of influence do not necessarily lie on the curve. Instead, they act as attractors that pull on the spline, creating a specific shape



according to their position and the extent of their influence. A shape can also be approximated by joining a series of points on a curve with straight lines. The precision and smoothness is then related to the number of points.

Besides being subdivided at a macro level, the form is ultimately broken down into a series of zeroes and ones, the ‘bits’ of data that are the base units for every binary system and thus the atoms of the virtual world. Bits are discrete and scalar; they have no properties except magnitude. These two characteristics make themselves manifest even as the amount of data increases exponentially.

The discreteness of data both facilitates and reduces plastic operations. The interaction of elements and any semblance of uncertainty are illusions, since each basic unit has only two absolute states. Building Information Modelling (BIM) is increasing the amount of information that can be contained in a digital model, but this increase does not include a synthesis of that information. Each property – material, finish, fabrication – is assigned separately. At the same time, however, this discreteness is a great advantage when information must change from one form into another. Absolute states are easy to convey and nothing gets lost in translation when

the messengers are binary. A massed shape can become a stress-and-strain analysis, a structural model, a fastening schedule, and cut sheets for a CNC router without losing its integrity. Solid turns into surface turns into wireframe turns into spreadsheet – but each metamorphosis requires the input of yet more information. The function of the digital imagination is the management of these different states and how they will eventually relate. Just as the clay former must be the master of water, the digital modeller must be in control of the data that informs the virtual world.

This control is derived from rational and logical thought. When I work with clay I might be thinking, “This clay is sticking to my hands. It will most definitely be too sticky for molding” – although

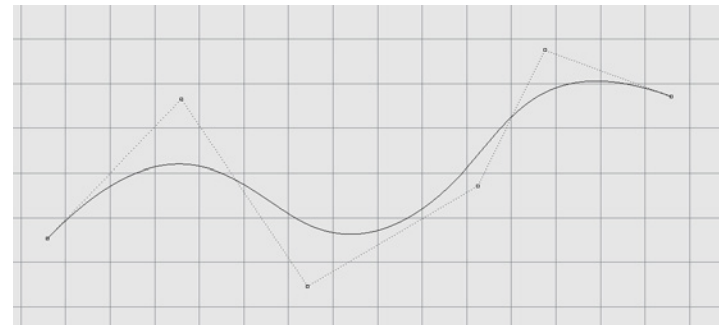

I.15. Spline drawn in Rhino.



1.16. Freshly dug clay.

of course I would not be thinking this in words, but in sensations. Working digitally, in contrast, the thoughts might proceed “If I revolve this profile around this axis, it will produce a three-dimensional object having these proportions”. Bypassing rationality allows the clay former to understand immense complexity and interdependence through the fingers. Digitally, though, complexity is only managed through the multiplication of information. This is most obvious in parametric software, for example in the program Grasshopper that creates parametric geometries for the modelling program Rhino 3D. A form in Grasshopper is created by starting with very simple inputs and performing successive operations until the desired result is achieved. The entire process is mapped out in a flow chart that displays each transformation. The discreteness of data is an asset because the effects of each step can be traced or reversed. When I was forming bricks, some would develop cracks while drying. This occurred at random intervals and affected around one brick in twenty. These cracks could have occurred for any number of reasons, from the amount of sand in the mixture, to the way I filled the mold, to the way it was set down to dry, to the temperature and ambient humidity. It was impossible to determine the true reason for the cracks because each factor interacted with every other. A failed Boolean operation, however, has definite causes



I.17. Brick cracks.

– the adequacy of the geometry, the nature of the intersection – that can be corrected separately.

The only thing that gives a measurement to the virtual model is the amount of information it conveys. Dimensions are notional only, and the sense of space is abstract and relational. The model is not defined by its scale but by its scope, which normally reveals itself in the amount of bits a file contains. We use the language of

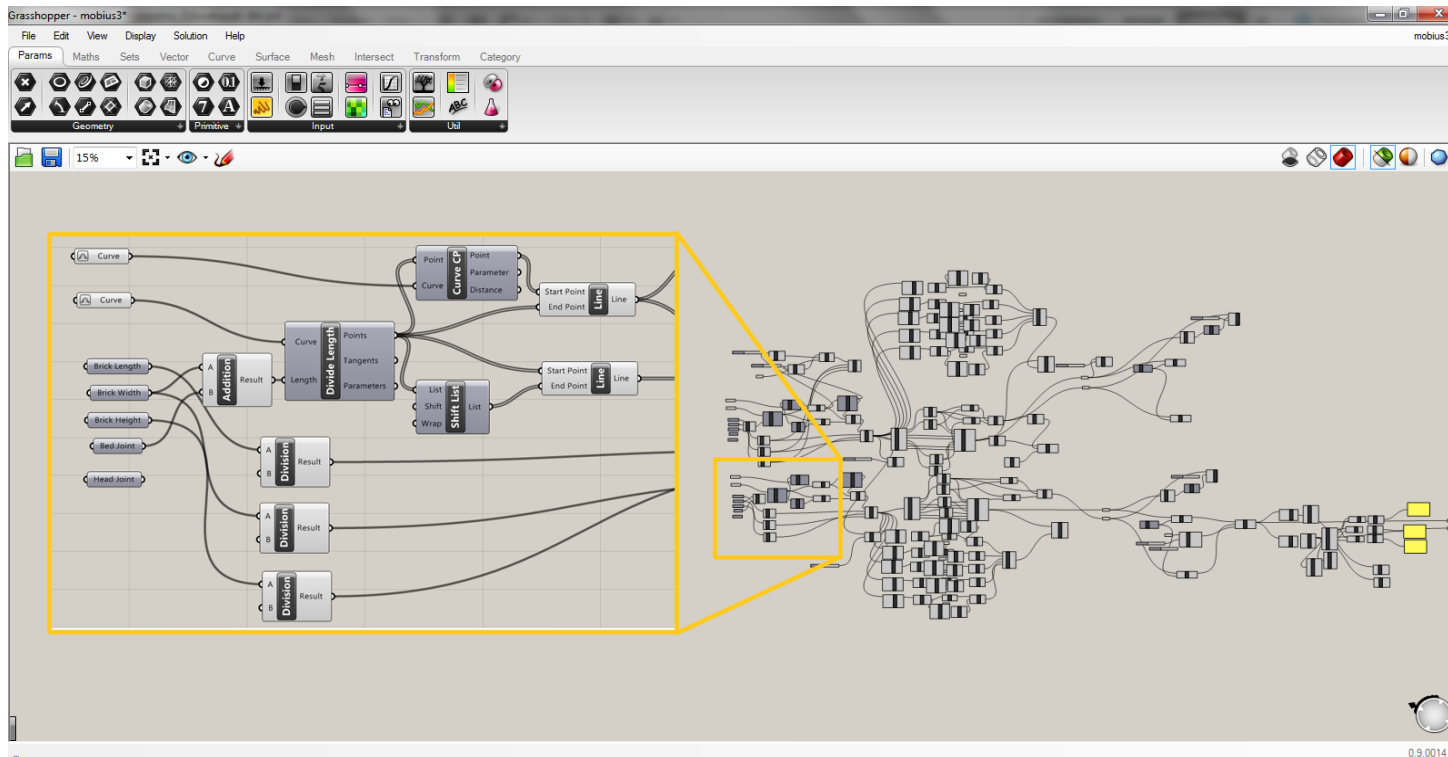

1.18. A Grasshopper program to parametrically create the solid shape of mortar between two bricks at different angles.

space to describe this characteristic, calling it the “size” of a file. The measure that determines our relative understanding of this property (what we would call a “big” versus a “small” file) is the processing capabilities of the computer. The processing capability is the rate at which electronic impulses can be detected, each electronic impulse representing the information of one bit. This means that the digital world is measured, ultimately, by speed.

In the physical world, we usually measure by scale of the body. Objects and tasks are all ultimately related to the human’s capacity and dimensions. Clay is hard to work with if it cannot be deformed by hand, is brittle if it can be snapped easily by a person, is gritty if the skin registers the sand particles. We can evaluate the substance through our muscles and our senses. These multiple channels deepen and broaden our knowledge of matter.

The possible intersections between digital modelling and clay are only just beginning to be explored. At a workshop held in Lisbon in April 2013, computer numerically controlled (CNC) machines were used to mill out blocks of hardened earth, as well as to make molds that were subsequently filled.¹⁰ Currently, machines act on clay like it is an ideal, uniform substance, suppressing its multiple conditions

and inconsistencies. To do otherwise would require constant and extensive inputs of information. Only the human imagination is just as alive and dynamic as the material. Only the mind working with the hand can adapt to state changes, errant stones, weather conditions, and all the ambiguities of physical matter.

Presented here are two worlds: two fundamentally different conceptions of the role of the plastic imagination. Both have challenges and advantages when applied to construction. Clay invokes the tangible scale and weight of matter, necessary because buildings are necessarily physical, whereas digital modelling facilitates the managing and transmission of information. The plastic imagination of the 21st-century designer must operate in the gap between these two worlds, because the distance between them is both a liability and a lost opportunity. When I am modelling digitally, I must know how the shape can be made in clay, and when I am working in clay, I think of how its behaviour could possibly be predicted with the help of digital tools. To foster connections between unpredictable, ambiguous matter and mathematical, rigorous virtual space would be a noble goal for contemporary architecture.



1.19. Clay too sticky for molding is dried on boards.





My first introduction to the craft of brick-making occurred on a hilltop in Umbria. There, I watched in awe as a brick-maker pulled off a loaf of clay, rolled it in sand, slapped it into a metal mold, scraped the top and smoothed it, and tipped the mold onto the warm sanded floor. The floor of this warehouse was almost completely tiled with the flat bricks in varying stages of moistness. Intrigued and moved by the beauty of the process, I asked to try. The clay was smooth and sticky, but the practised motions of the brick-maker turned awkward under my novice hands. I must use the edge of the stick, and not its surface, for even scraping. The mold must be carefully slid off the angled work surface and carried perpendicular to the floor. My first brick was misshapen and ugly, and the worker laughed and told me I should write my name on it. The fired bricks retained the entire story of their fabrication. The bottom and sides were rough and sandy, and the top bore the marks of the hand that had smoothed it.

Months later, I was searching for an operational brickworks in the outskirts of Warsaw – a surprisingly difficult task. After a few wrong turns and stumbling with my non-existent Polish, I was finally directed to a seemingly deserted yard, the only sign of activity being a thin plume of smoke from the kiln chimney. I wandered in tentatively, and came across a long shed lined with rows of drying



2.2. At Fornace Bernasconi in Castel Viscardo, Italy, each brick is hand-formed in a metal mold.
2.3. (opposite) The fired bricks.

bricks, one set of train tracks in the middle. I had the uncanny impression of having stepped into a mechanism that had been frozen in time and could recommence at any minute. These bricks, made by extrusion, were unapologetically machinic. They were aligned in military rows, stamped with the rolling stamp of the factory. The cut faces were rough, with stones that had been dragged across the surface, whereas the outside faces were even and subtly streaked from





2.4. These bricks clearly bear the marks of their extrusion.

2.5. (right) Brick-drying shed, Radzymin, Poland



the die. A set of rails disappeared under a closed fence door at one end of the shed. A glimpse past this fence revealed the extruder, drying clods dripping off hoppers, feeders poised to pour, everything enveloped in an unnatural stillness.

From these experiences, I came to the conclusion that bricks are honest records. The clay retains the traces of its manipulation. It is possible to read the process by observing the object. I thought that this was important for architecture, because construction processes are an aspect of culture that would otherwise be invisible and voiceless.

I subsequently visited a brick factory in Burlington, Ontario. There, the mechanism runs continuously and smoothly from the quarry to pallets ready for shipping. Clay is transported with conveyor belts, crushed, mixed with water, extruded, cut, and stacked on cars that move slowly through the long tunnel kilns. I expected to read this precision and automation in the finished product. This factory, however, deliberately employs devices to disguise the manufacture of its bricks and to evoke the irregularities of hand-formed products. It makes use of rolling stamps to dimple the surface and dull the cut edges. It drenches the outside surfaces with uneven pulses of

multicoloured sand to produce more variation. Although the only humans who actually touch the bricks in the factory are the quality control workers who pull out unsound specimens before they are automatically packaged on pallets, the bricks are marketed with words such as “historic feel”, “classic”, and “traditional”:

With both light and dark colours, the Signature Series is appropriate for both contemporary and traditional designs. It features simulated tumbling and rolled edges to give the bricks a handmade look.¹

Brick is associated with stability and tradition, and yet this permanence is undermined by the desire for choice and self-expression. Only a handful of factories make brick that is shipped throughout the country. Instead of reflecting the soil of an area, colours and textures can be chosen out of a catalogue. It can be part of the package of options offered by builders who allow their clients to choose paint colours and finishes in a “spec” home.² The brick wall is no longer a solid mass. It is a thin veneer that wraps a wood-framed house. The change of function as well as change in production methods have not been translated into the form and expression of the brick. This phenomenon is called skeuomorphism.

2.6. A rotating stamp in the brick factory in Aldershot imprints 'handmarks' in an extruded column of clay.



Skeuomorphism occurs when there is a disconnect between the reality of an object and its cultural significance; in order to retain the significance, the object is superficially altered to conform to cultural expectations. The sign is detached from the substance. We are accustomed to reading deeper meanings from very shallow signs – words on paper, for example. In that sense, all art participates in two realities, the reality of its physical creation and the reality of the world it represents. Architecture, however, is charged with the synthesis of these two realities. Its physical manifestation influences the way we live. It shapes the world through the way it is shaped.

In *Surface Architecture*, David Leatherbarrow and Mohsen Mostafavi declare that “production and representation are in conflict in contemporary architectural practice”.³ For them, the display of mechanical fabrication as well as the “picturing of historic profiles in nostalgic recollection” are both problematic.⁴ They advocate instead for a remaking of the prefabricated object through appropriation and site-specific deployment.⁵ However, to say that the life of an object begins only with its use on site denies the importance of the processes that produced the object. Every object that arrives on a construction site has mobilized a system of infrastructures that have removed material from the earth, transformed it, and transported it.

Whether or not we are aware of it, this system determines the nature of our interaction with the physical environment. As the story of the three bricks demonstrates, each object has its own particular history. Skeuomorphism masks that particular history by substituting it for a general one.



2.7. “Hand-made”?

2.8. (opposite) The factory in Burlington produces bricks that are shipped all over North America.



This general history could also be called mythology or “wish images”, to use Walter Benjamin’s phrase.⁶ Benjamin argues in *The Arcades Project* that masking an object’s technical origin also conceals the labour conditions under which it is produced.⁷ The manipulation of the mythologies of society is a privilege of the ruling class. The danger, for Benjamin, is that the propagation of one history prevents the present from engaging dialectically with the past.⁸ Although Benjamin saw these mythologies as symptomatic of 19th century capitalism, the continuity of forms through changing technologies is as old as architecture itself. Each time a new material is introduced, it is assimilated into culture by styling it according to previous traditions. Greek stone temples were carved to imitate their wood predecessors. When iron was first introduced, it was given the forms of classical Hellenic orders. Reinforced concrete was made to look like stone.⁹ According to Luis Fernandez-Galiano, these formations “are not functional, technical or expressive archaisms, but manifest the economy derived from the symbolic persistence of places and forms.”¹⁰

However, this economy can only exist if we can understand the symbol. Every object necessarily bears signs of its making. We choose to either acknowledge or ignore them. In fact, the bricks

produced at the plant in Burlington look nothing like hand-made bricks. The imprecise edges are mechanical in their unevenness. The imprecisions do not have the direction, location, or shape they would if they were made by hand. It is only comprehensible because our imagination replaces its reality with an idea. As production processes increase in capacity, these ideas become ever more simplified in order to be legible to a greater amount of people. The complex logic of production is suppressed to achieve universal appeal.

Brick is especially susceptible to simplification. Due to its use in all parts of the world, it acts metaphorically as the Rosetta Stone of culture, everywhere symbolizing earth, fire, and the human hand. Part of the richness of language, though, is its constant evolution and regional specificity. By uninhibitedly expressing the processes that generate an object, we can encourage an interpretation that is based in the specific realities of its situation. The *situation* of a built object not only comprises its manifestation in a particular place but also its participation in a system of construction and its significance in the minds of its inhabitants. Benjamin’s dialectical approach involves examining the situation of the present alongside the past, using the comparison as a catalyst for action.¹¹ Examining the current possibilities for brick in relation to its extensive history



- 2.9. Hand-formed Buckinghamshire brick.
- 2.10. Metal brick molds.
- 2.11. Traditional brick forming.
- 2.12. Collection of special molds.

is one way of applying this approach. If this method of working is combined with a profound attention to the situation of the material, then it might be possible to create a dialect as well as a dialectic: a language of brick, particular to a location, that addresses the past through juxtaposition as well as affinity. In a globalized world, is there still a place for architectural dialects?

When designing brick at Grymsdyke Farm, it was important for me that the brick was not simply a sign but in its substance acknowledged both the heritage of the farm and the current architectural climate. The county of Buckinghamshire has a long history of brick construction, beginning during the Roman empire and continuing until the present.¹² Today, the solid brick walls of the past are no longer viable; they have been superseded by multi-layer cavity walls, although the expression of the brick facing remains the same. I wanted to question the standard aesthetic of brick while still valuing the craft of bricklaying and the high-quality clay of the soil.

The choice of hand-forming bricks in a digitally fabricated mold was made on the basis of the resources available at Grymsdyke Farm. The CNC router expanded the potential for making wooden molds, and the clay from the ground provided the raw material. A visit to local



2.13. The first mold was fabricated in two pieces using the CNC router and subsequently assembled.

brick factory provided a precedent for the forming process. There, clay is thrown into five-sided molds, the top scraped smooth, and the mold inverted to release the bricks. I modified this process to suit the unusual shape of the brick. Using a four-sided mold, I could



2.14. Traditional brickwork of Buckinghamshire: The Cottage at Grymsdyke Farm.

FORMING |

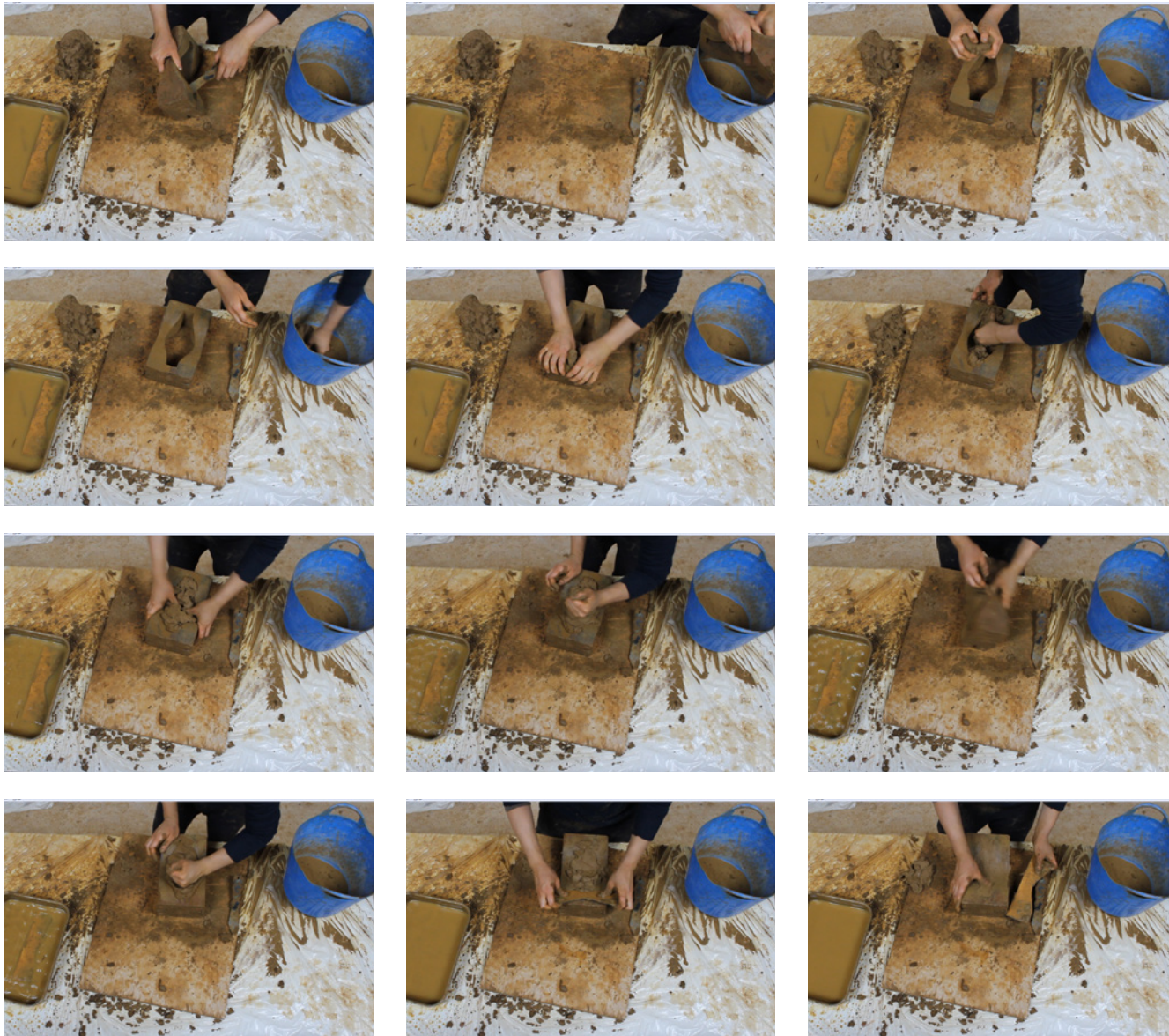

2.15. The forming process.

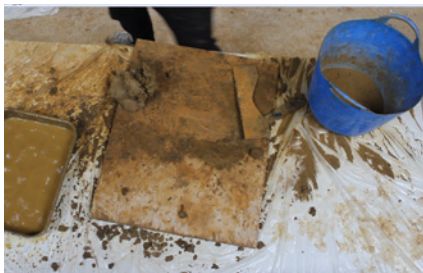

more easily control the contoured profile of the brick by scraping both the top and the bottom. The smaller profile of the brick made it very difficult to throw clay accurately into the mold, so instead I pressed the clay into the ends and then filled the middle. I also used a secondary frame to demold the bricks, instead of inverting the mold. Tapping the mold lightly on its corners, then knocking it on the other frame, released the brick with minimal distortion. Just as in the traditional method, the use of sand as a mold release was necessary, both on the mold and on the clay.

All of these actions are registered in the finished bricks. I did not realize that the sand I was using would change colour in the kiln from gold to dark red. This altered the appearance of the fired bricks, slightly masking their bright orange colour. I later switched to a sand that remained inert in the kiln. The sides of the brick that were open in the mold have a very different texture than the sides that were closed, with the sand coating. The open sides are smoother because they were scraped and wiped with water. Creases in the body of the brick indicate the pressing method I used to fill the mold.

The first mold I designed was milled in two pieces that were then permanently joined. Using the CNC machine to rout out the inside



2.16. The finished brick.



2.17. In the first mold I made, the inside corners were rounded from the radius of the CNC drill bit. This formal quirk was imprinted on all bricks made from that mold.

2.18. The second mold was made from four pieces assembled into two angles and held in place by a retaining ring.

2.19. Pattern and cast: a test of sand-casting aluminum.

form resulted in the corners of this form being rounded from the drill bit radius, a mark that was preserved in all the bricks made using that mold. To test a different process, I made a second mold in four pieces, assembled into two angles that could come apart. It soon became apparent that the additional time and effort needed to disassemble this mold were not compensated by a more precise brick, and the first process was in fact more efficient.

The third mold was developed out of the desire to eliminate the need for sand in the forming process. I thought, perhaps, that the rough texture of the sand, if cast into the side of the mold, would act the same way as the sand itself. Mold 3 was therefore designed to be made of metal. Gommès Forge, about two kilometres from Grymsdyke, produces pieces in milled sheet metal, wrought iron, and cast metal. I created a plywood form for use in the process of sand casting aluminium, where a fine sand is packed around the positive pattern, which is then removed and the void filled with molten metal. The cast failed, however, because the initial form was too thin. I was informed by the blacksmith that although sheet metal can be very thin and strong, cast metal must be almost as bulky as wood to have the same strength. As well, since the clay adhered even to the metal, sand would still have been necessary. It



2.20. The rows of sand support the drying bricks from underneath.



2.21. The drying racks.



2.22. Creases.

They are one indication of the forming process of the brick. Creases show that the original mixture was stiff, not liquid; their direction indicates the force applied, and their unevenness reflects the imprecision of hand-thrown clay. Normally, they occur horizontally from gravity, but the way I filled the narrow ends of the mold, and then the centre, produced unusual diagonal lines.

was not the texture of the sand but its mobility that provided the releasing properties.

The unusual brick shape also posed a challenge for drying, since the curve required support from underneath. A profile matching that of the brick was laser-cut and used as a rake to shape rows of sand, onto which the raw bricks were placed during the first day of drying. Once they had dried enough to hold their shape, they could be moved out to the covered passageway, where open shelves and continuous air flow aided the evaporation of moisture. Initially, the horizontal slats used as shelves were making marks on the bricks, but I realized that shimming each slat on an angle allowed the brick to rest evenly. The fired bricks gain additional significance through their relationship to the existing constructions of the farm. In colour, they are similar to the walls of the stables and cottage. The clay from which they are made is under and around them. The production of the Grymsdyke bricks is profoundly embedded in the place of the farm, and yet, the bricks also express more universal values of labour and energy.

2.23. Rethinking the tradition: the Grymsdyke brick experiments inhabit the old brick farmhouse.







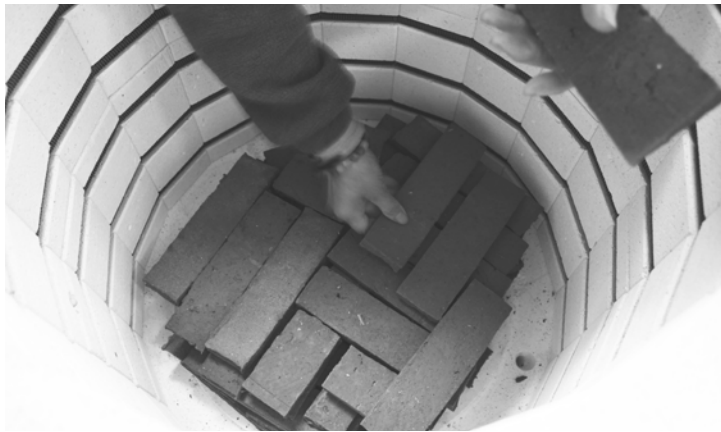

The parallels between bricks and bread are extensive. The raw materials, wheat and clay, must be ground and mixed with water to produce a dough, which is shaped to produce rectangular loaves. These units are then baked. When bricks are firing, the kiln even exudes a moist, yeasty smell comparable to that of baking bread. The similarities between these two substances speak of the primordially of these two basic units, their roles as sustenance of civilization. The product as well as the process are fundamental expressions of culture; control of fire is one of the mythological conditions for human society.¹

These archaic associations are lost in an industry driven by the urgency of the market economy. Environmental impacts are magnified by the sheer quantity of worldwide brick production – China alone produces 900 billion bricks per year, burning 100 million tons of coal to do so.² Brick burning is a process that consumes large amounts of combustible fuel, often produces toxic emissions, and requires the transportation of the heavy green bricks from the drying area to the kiln. Especially in developing areas, reducing the amount of energy needed to produce brick has been a continuing preoccupation of corporations, governments, and aid agencies.³ This often involves introducing more efficient kiln technologies and fuel sources. Human work is one form of energy that seems insignificant compared to the combustion fuel. And yet, it is the most important input. Technology is only efficient if it is correctly exploited.

The energy expended to make brick is not completely lost; it is preserved in the durability of the material. This balance is expressed by the distinction between “initial embodied energy” and “recurring embodied energy”. The initial embodied energy of a substance is the energy per unit needed to produce and install the product.⁴ This includes quarrying the raw material, transporting the material to the manufacturing facility, manufacturing the material, transporting

3.2. Baking tiles,
Grymsdyke Farm.
3.3. (opposite) Bricks
stacked in an updraught
kiln, Castel Viscardo, Italy

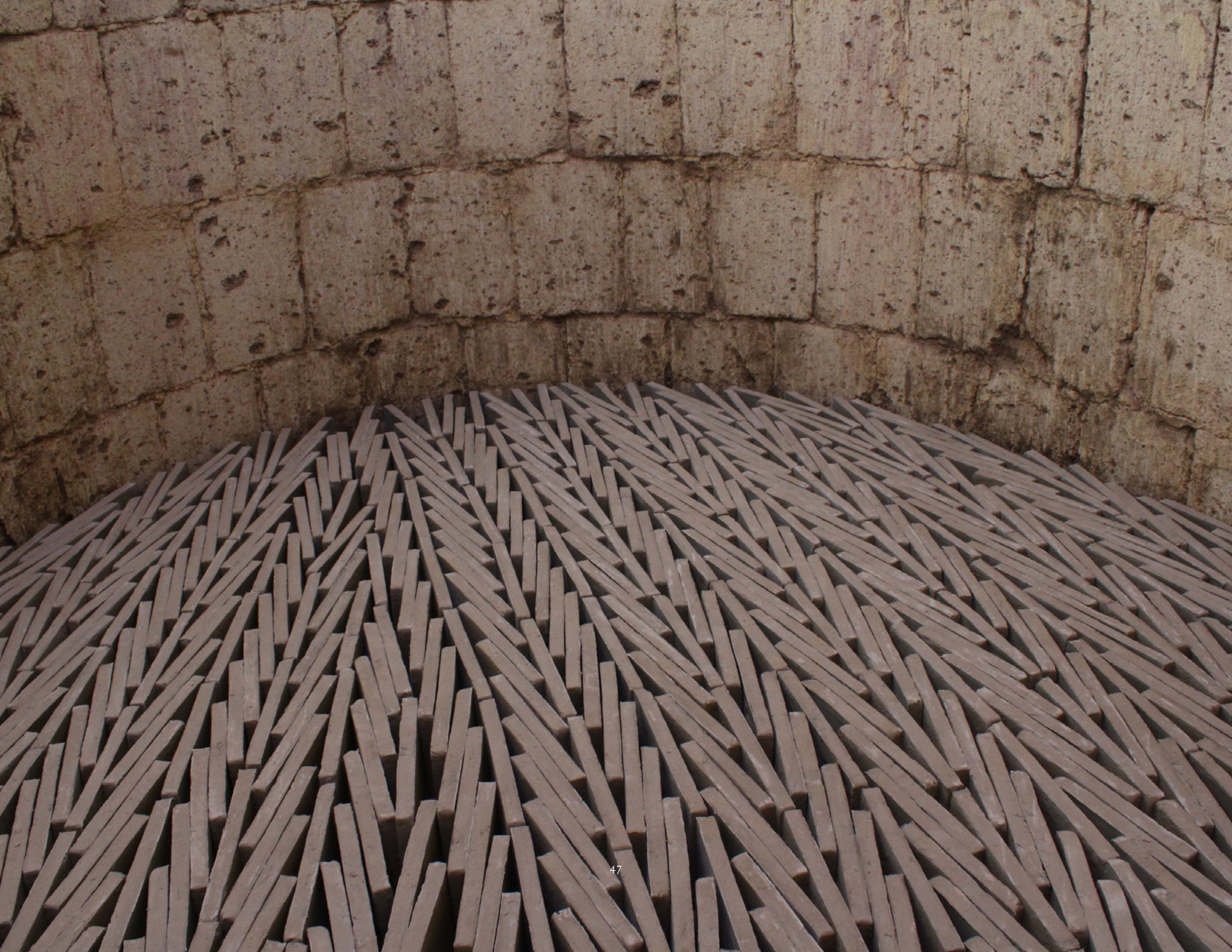

it to its final destination, and installing it according to its purpose.⁵ It is often evaluated in parallel with the recurring embodied energy needed to maintain the material over the course of its useful life.⁶ Embodied energy is a helpful measure for construction because it is a property of a material and not of a building; as such, it accounts for processes that are not directly related to the assembly of the building. As buildings become more energy-efficient, that is to say, use less operating energy, the embodied energy of their materials will become an increasingly important indication of construction's environmental impact.⁷

Firing clay produces irreversible chemical changes in the substance. A firing cycle can take anywhere from 24 hours to 3 weeks and normally achieves temperatures of around 1000°C. Up until around 500°C, the bricks are dried, and the clay's moisture content is reduced to zero.⁸ Often, manufacturers will set up a preliminary drying kiln that recycles the waste heat from the firing cycles, reducing the amount of energy needed for this first phase. From 500-800°C, the hydrate groups contained within the molecular structure of the clay are driven out in the chemical process of dehydration. At 573°C, quartz inversion occurs, when the molecules of silicon dioxide straighten and rearrange themselves. Finally, at around 900°C,

vitrification occurs, when crystals of mullite sinter and interlock to produce a lattice that binds the whole brick.⁹ This needle-like compound is what gives fired clay its distinctive durability and resonance.

Durability is also a key characteristic of Hannah Arendt's definition of "work".¹⁰ For Arendt, work and labour, two fundamental human activities, are differentiated by the lifespan of their outcomes. Labour produces goods that are consumed by the process of living, whereas work produces the durable objects of human artifice – its tools and constructions.¹¹ This durability also permits the objects to store energy as information and future economies of effort. As Luis Fernandez-Galiano writes, "there are hence two senses in which expended energy is actually conserved [in construction materials]: as material organization making for a more efficient subsequent use of energy, and as mental organization resulting from a process of acquiring experience, which likewise leads to increased efficiency."¹² These future economies are contained in the tools, in the object, and in the mind of the worker.

Kiln workers must know how to load the bricks to make efficient use of space while still permitting air flow. They must know when to

3.4. (opposite) Kiln cars loaded for firing in a tunnel kiln, Burlington, Ontario.



introduce fuel and in what quantity. They must know for how long the bricks should remain in place to be properly fired. This knowledge manifests itself differently depending on the kind of kiln. In Castel Viscardo, Italy, the updraught kiln at the Fornace Bernasconi is essentially the same as the ones used by the ancient Romans. Wood off-cuts from a nearby sawmill are loaded underneath the firing chamber. The hot air passes through the stacked bricks until the entire column glows red. The overseer of a completely automated plant in Burlington, Canada draws firing profiles as graphs on a computer. The profiles are then translated into natural gas flow in the tunnel kiln. In Chesham, UK, the kilns are fired with either wood, coal, or oil. The workers judge temperature by the colour of the flame, or by comparing the colour between different batches of bricks. The firing is only successful if there is synergy between the capabilities of the operator and the potentials of the equipment.

Brick kilns can be divided into two categories, intermittent and continuous, the former being often less energy-efficient and having less capacity than the latter. The simplest structure for intermittent firing is a clamp. The green bricks are stacked so that they make their own kiln. The entire stack is often plastered with raw clay for extra insulation; still, the outer layers of bricks are often sacrificed because

3.5. Diagram of an updraught kiln

Dimensions:
approx. diameter 4m

Output Capacity: ~17,000
bricks every three weeks
(around 800 bricks per
day)

Fuel: Wood

Efficiency: ~ 3.0 mJ per kg

Employees in factory: 13

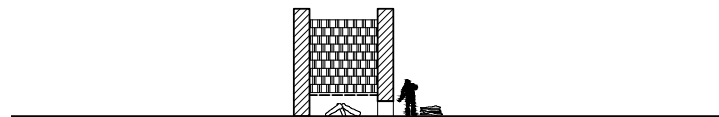



3.6. View into an updraught kiln, Castel Viscardo, Italy.
The walls of the kiln are massively thick for insulation.

of insufficient heat. Emissions are high and often contain toxic fine particulate matter. A clamp firing can take up to three weeks and requires a lot of labour for loading, feeding the fire, and unloading.¹³ Another kind of intermittent kiln is the updraught kiln, which takes the form of a simple enclosure, often with a vaulted roof. The fuel is loaded in chambers at the bottom and the hot gases pass through the bricks and into a chimney.

Continuous kilns can be divided into those where the fire moves and the bricks remain stationary, and those where the bricks move and the fire remains stationary. Tunnel kilns, the most popular example of the second type, are now the favoured method in developed countries. Bricks are loaded onto kiln cars which move slowly first through a drying tunnel and then through the firing tunnel. In the most advanced operations, the entire process is automated. The vertical shaft brick kiln is another example; green bricks are loaded at the top of a stack and fired bricks removed from the bottom. The entire stack is moved using jacks. Conversely, in the Hoffman kiln, the fire is moved continuously around a permanent circular or oval structure. Bricks are loaded and unloaded from the loop's various chambers accordingly, and fuel is poured in through holes in the roof.¹⁴ The same concept, but linear, is used for the Bull's Trench kiln,

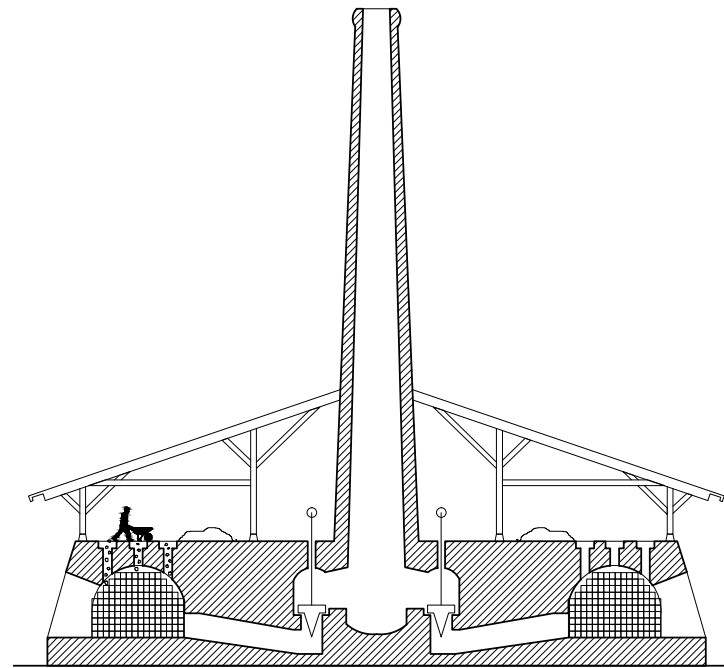

3.7. Diagram of a Hoffman kiln

Dimensions:
approx. 30m x 45m

Output Capacity: ~ 10 000
bricks per day

Fuel: Coal

Efficiency: ~ 1.6 mJ per kg

Employees in factory:
unknown (only 1 seen)



3.8. Top level of a Hoffman kiln, Radzymin, Poland

popular in the developing world due to its simplicity of construction and high output.¹⁵

Calculating the exact embodied energy of a brick is very difficult due to the varying efficiencies of kilns and the moisture content and properties of the clay at the start of the firing cycle. The vertical shaft kiln is cited as being the most efficient, using as low as 0.7 megajoules per kilogram of fired brick.¹⁶ In contrast, a clamp kiln can use between 3 and 8 megajoules per kilogram.¹⁷ Interestingly, the vertical shaft kiln is even more efficient than modern tunnel kilns, which normally use between 1.1 and 2.5 megajoules per kilogram.¹⁸ However, the overall environmental impact also depends on the kind of fuel. Natural gas is used most often in tunnel kilns; it burns cleaner than coal or other solid fuels. Wood, coal, and oil are also widely used, with coal being the most popular, but the burning of car tires, plastics, and other waste products in kilns in developing countries is generating concern about health and environmental effects.¹⁹

In North America, a few large companies supply the bulk of the material for the entire continent.²⁰ Brick production in India, China, and other developing countries remains unconsolidated and

3.9. Diagram of a tunnel kiln

Dimensions:
approx. 6m x 150m

Output Capacity at 100%:
264 000 bricks per day

Fuel: Natural Gas

Efficiency: ~ 2.3 mJ per kg

Employees in factory:
14 hourly + 6 staff

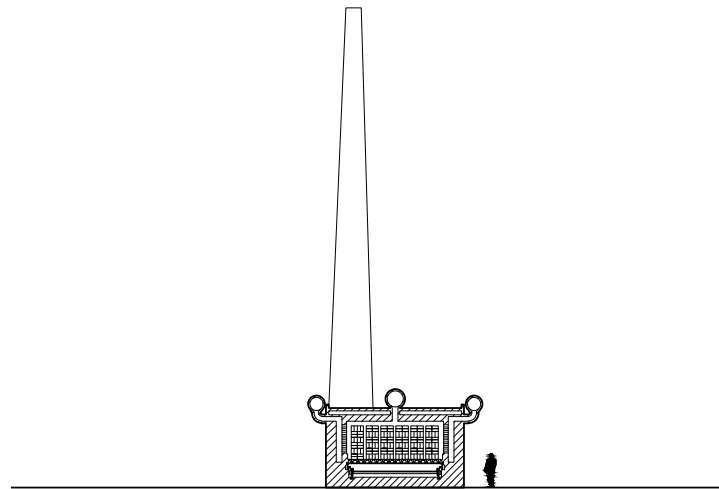



3.10. A modern tunnel kiln, Burlington, Ontario.

includes hundreds of thousands of small and medium enterprises.²¹ The simplicity of the raw materials and their preparation contributes to brick's popularity; as well, rapid urbanization in these areas fuels the demand for construction materials. These small factories are the greatest contributors to air pollution and greenhouse gas emissions, since most do not have the capital to invest in better kiln technologies. And yet, they also provide benefits in the form of local jobs and reduced transportation for the finished product. Brick-making can also contribute to social empowerment by enabling independent groups and communities to build their own assets.²² In Harun Farocki's film *Zum Vergleich*, a group in India fires a domed brick structure in place. The structure becomes the rooms of a school, and the bricks that were fired inside can be sold to help finance the school's activities. This kind of project creates very different conditions than the monotonous menial labour of many low-tech brick factories.

Unfired bricks, compressed using a small amount of cement, lime, or fly ash as stabilization, are acclaimed as a possible alternative.²³ In reality, they remain unpopular due to a combination of technical and cultural factors. They normally have less compressive strength, water resistance, and durability.²⁴ Raw earth is regarded by many cultures

3.11. Diagram of a vertical shaft kiln

Dimensions:
approx. 6m x 6m

Output Capacity:
4560 bricks per day

Fuel: Coal

Efficiency: ~ 0.8 mJ per kg

Employees: variable

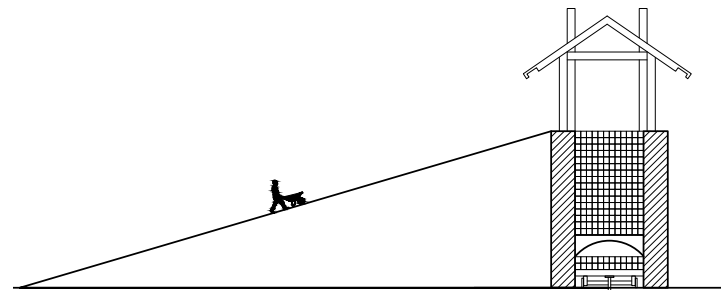



3.12. Diagram of Grymsdyke Kiln

Dimensions:
approx. 1m x 1.7m

Output Capacity:
120 bricks every 2 days

Fuel: Electricity

Efficiency: ~2 mj per kg

Employees: 1

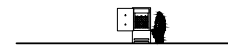

as an inferior or second-class building material for that reason.²⁵ As well, a lower durability makes them much harder to transport and reduces their exchange value. Given that fired brick has too many benefits to be easily abandoned, improvements must be made to the current industry.

It would be both impossible and undesirable to imagine that for questions of energy efficiency, all brick making must be consolidated into large-volume automated plants. Arendt cautions against uninhibited mechanization, warning that it turns activities of “work” into activities of “labour”, with a corresponding sense of futility.²⁶ The difference does not lie in the amount of physical effort required, but in the mental attitude of the worker. Indeed, when watching *Zum Vergleich* it is hard not to compare the African village that builds itself a school, singing and dancing the whole way, to the expressionless face of a worker in a German factory who must simply watch the bricks coming off the production line. In *The Outliers*, Malcolm Gladwell describes the three criteria for meaningful work: it must have autonomy, complexity, and a relationship between effort and reward.²⁷ He describes the work of Chinese rice paddy farmers as meaningful because they could, through work and the thoughtful application of technique, directly influence the yield of

their land. Would it be possible to imagine the same attitude in brick manufacture, where each facility works to develop the most efficient firing process for its location and production? In this way, the quantity of embodied energy would decrease as the quality of human input increases.

The success of this approach would depend on the dissemination of knowledge and the availability of affordable solutions. Increasing the insulation kiln walls is one way that energy use could be lowered. Another possible strategy is to mix small amounts of fuel into the clay mixture, allowing the bricks to self-fire.²⁸ The stacking pattern of bricks inside the kiln might also be a factor. The molding process and drying strategy could become unique to each brickworks. In some areas, there might be opportunities for co-operation with other industries for recycling heat and sharing fuel. The reward for this optimization work would be more cost-effective and locally specific bricks.

Brick-making in the developing world will need to undergo some modifications to decrease fuel use and pollution. Hopefully, it will be possible to introduce more efficient kiln technologies and molding processes without compromising the diversity and distribution of



3.13. Kiln unloading, Grymsdyke Farm.

the industry. The transformation of local materials into durable construction products remains an important process for the economic and cultural sustainability of a region.

At Grymsdyke Farm, I was lucky enough to have the help of Jessie Lee, a former professional ceramicist, for the operation of the kiln. Instead of requiring multiple tests to determine the speed and temperature of firing, I could rely on her years of experience. We chose a firing profile that began very slowly, in order to dry out the bricks without risking cracks from escaping steam. The temperature was held steady for one hour once it had reached 200°C for that reason. At 600°C, it was held again for one hour for the process of quartz inversion – the change in formation of silicon crystals. It then finished its cycle by heating to 1000°C. This profile was chosen after the failure of a first test where the kiln was fired to 1100°C. During our visit to the H.G. Matthews brickworks in Chesham, they had told us that their kilns reach that temperature. Considering the similarity of their clay to the one at the farm, we believed that extra heat might improve the strength of the brick. However, it caused a reaction in the sand that I had added to prevent shrinkage. The bricks came out dark red and very friable.

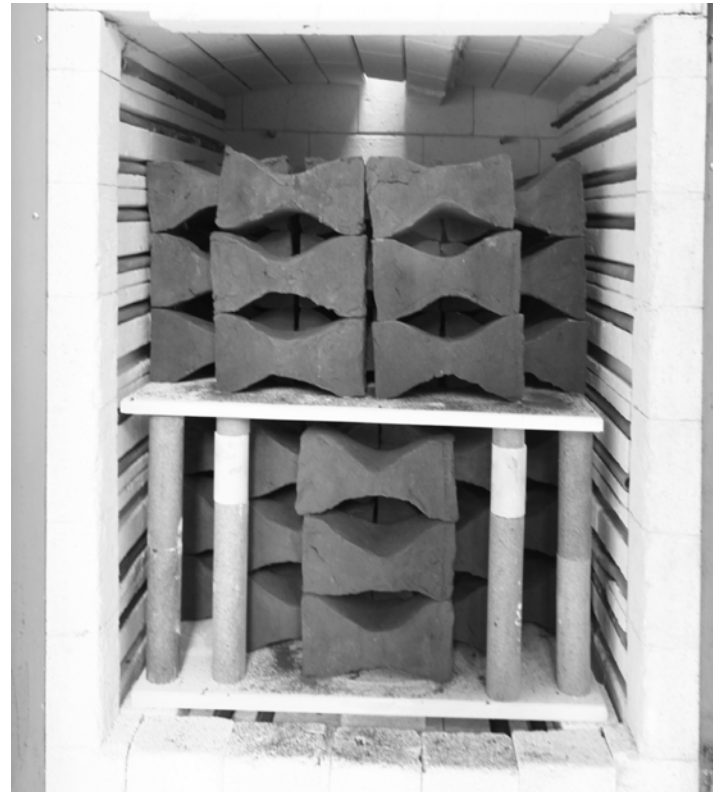

3.14. Kiln stacking,
Grymsdyke Farm.

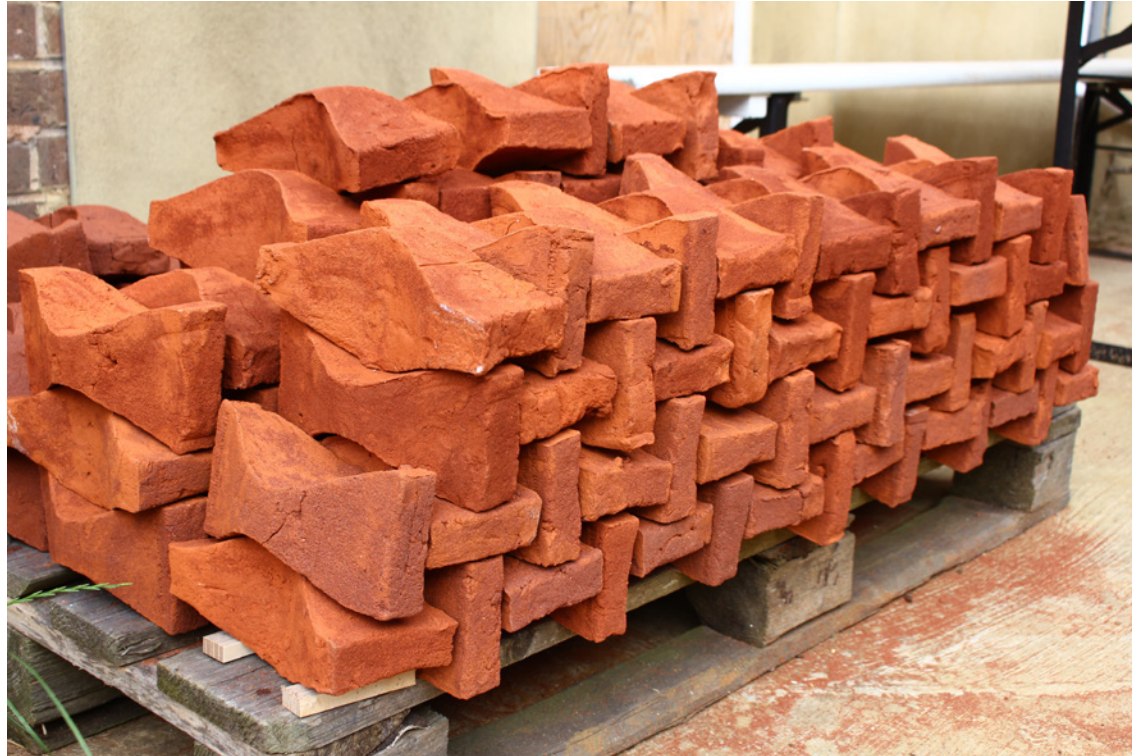

3.15. Stacking for storage after firing.

In traditional brick firing, the bricks must be carefully arranged to ensure air flow between them, but the shape I had designed for the module easily accommodated this condition. I used a wheelbarrow to bring bricks from the outside shelves to the kiln, and then from the kiln to a pallet outside. The versatility of the module was apparent when I stacked the bricks after firing. Unlike the kiln arrangement, the stacking pattern could be very dense, permitting the efficient storage and transport of the units.

The quantity of energy per unit embodied in the Grymsdyke Farm bricks is relatively high, since there are no economies of volume and the kiln is small and intermittently fired. However, it also embodies a high quality of human input. The worker (me) was deeply invested in the outcome and it has had a profound effect on the small community where it is located. In many manufacturing operations in the developed world, this quality and investment is lacking. This is partly due to the high volume of output and the complexity of the equipment, which forces the worker into specialization and reduces their control over the process. This project is a prototype, and as such the process is not optimized. Instead, it serves to open discussions on the potentials of small-scale operations.



3.16. Sand traces left in the kiln.
3.17. (opposite) Brick loading.







Bricks and mortar have been a pair since prehistory; the evolution of one will undoubtedly affect the other. The future of brick must therefore be considered concurrently with the future of mortar. Lime and sand were historically the primary ingredients of mortar, although additives such as crushed brick, ash, clay, or even rice were used to improve strength and workability.¹ At the beginning of the twentieth century, Portland cement gradually started to replace lime. It is harder and sets faster. This hardness, though, is limiting; it requires the introduction of expansion joints and hinders the reuse of the bricks. Today, cement and sand mortars remain most prevalent, although epoxy resins can also be used. All mortars, however, share some characteristics: they are thick fluid substances that bind solid modules. Mortar allows a rigid system to become flexible, but this flexibility requires skill and craft to manage. The concept of construction tolerance is made manifest in a mortar joint.

Construction tolerances can be divided into two categories: material tolerance and assembly tolerance. Material tolerance reflects the accuracy to which a part can be made. This can vary due to inconsistencies within the material, such as wood warping or clay shrinkage, or due to the way it has been machined. Assembly tolerances arise when a part is installed. Time constraints, part

suitability, and worker skill level can all affect the precision with which parts are fit together. In much of North America and Europe, the cost of work now greatly surpasses the cost of materials. This is leading towards the development of “fool-proof” systems that compensate for unskilled labour with more precise parts. Masonry units can now be found with interlocking knobs, like a Lego brick², or with profiled edges that nest the units to each other.³ These systems, however, resist any configurations that were not designed into the units.

4.2. A brick chipped to fit an acute corner.



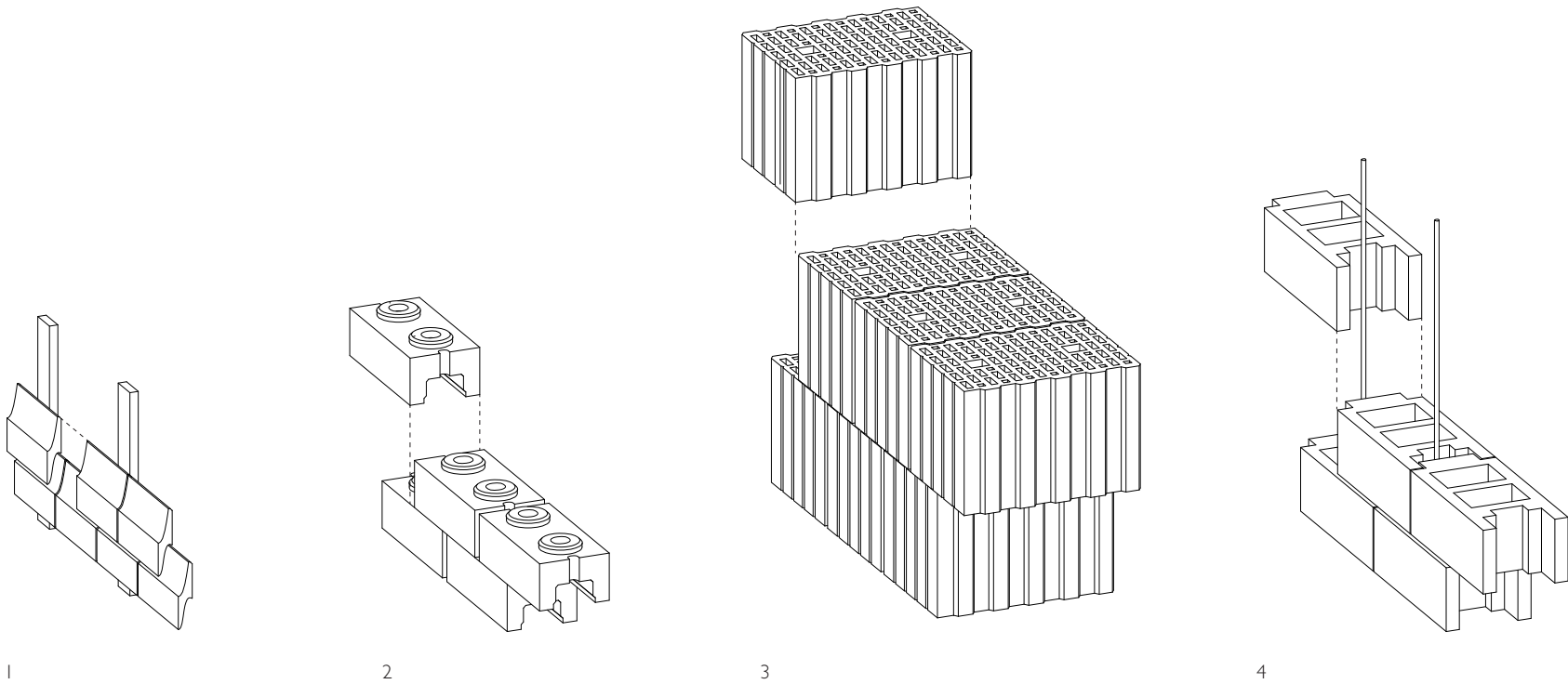

4.3. Some proprietary masonry systems.

1 Novabrik Siding. The shingle-like brick assembly requires no mortar.

2 Habitech interlocking bricks. Intended as a low-cost compressed-earth system for developing countries. Mortar is not needed for every course.

3 Porothem insulating clay blocks. These are assembled

with a thin layer of adhesive (~1mm) between each layer.

4 Cercorp Flexlock mortarless wall system. The blocks are fed onto rods which are subsequently post-tensioned. Mortar is required only on the bottom

course.

Tolerance outside of construction and machine fabrication has a positive connotation. It evokes a spirit of openness and acknowledgement of the other. It is with this spirit that mortar accommodates the inconsistencies of bricks and existing conditions. Increased precision in construction could potentially reduce costs and time by reducing the amount of corrections that must be made on site.⁴ Nevertheless, the widespread application of parts prefabricated with robotic exactitude should prompt an evaluation of the disadvantages as well as the benefits of small tolerances.

Mortar has many practical disadvantages. Like on-site welding, mortaring is an expensive and messy “wet” process, requiring specialized labour, tools, and working conditions. It cannot be done in temperatures below zero degrees. Only a certain number of courses can be laid at a time before it must be left to dry. The mix must be made as the worker uses it, to ensure best strength and workability. The worker must have knowledge of the substance’s capacity and the skill required to work with it.

For structural applications, the construction industry is moving increasingly towards thin-joint masonry systems, in which precision-ground units are assembled with only a few millimetres of adhesive.

The unpredictability of working with clay creates tiny variations even among the most carefully controlled bricks. Even in completely automated production, the dimensions of finished bricks can vary by around 2%.⁵ This means that the calibration process must occur only after the modules have been fired. In some systems, this calibration is refined to an extent that no mortar is needed at all – the blocks are simply threaded on rods and post-tensioned, forming a stable and rigid wall system.⁶ In other systems, the adhesive is applied with a roller, eliminating the skill needed to judge the amount and distribution of mortar.⁷ The joints between units can be carefully controlled; however, adapting a system with tolerances to the fraction of a millimetre to site construction, with tolerances in the centimetres, remains a challenge. In thin-joint systems, the bottom course of brick must still be laid with conventional mortar in order to prepare a level surface.⁸

Here, the first real purpose of tolerance becomes apparent. Although a dimensionally perfect building that hovers over its site might be incredibly efficient, architecture, in reality, requires at least some kind of involvement with the ground. To assume that the wild and unruly earth could be controlled with precision would be a sign of both hubris and wishful thinking. Tolerance, therefore, serves to negotiate



4.4. The first courses of bricks of the Terracott.

between a necessarily imprecise world and a precisely made object. It is this form of tolerance that allows for the naturalisation of the built object as described by David Leatherbarrow in *Uncommon Ground*. Leatherbarrow describes all constructions as alien to their sites. Even supposedly vernacular processes, such as the whitewashing of Greek village houses, imply a resistance to and a rupture from nature.⁹ In this way, he justifies the use of prefabricated assemblies and modern construction materials. However, he maintains that the integration of the object into its topography should be the end goal of design. This can be achieved in two ways:

*the modification of technical objects in building construction, so that they can be reconciled with the territorial exigencies of a project, and the appropriation of these things into the practices of practical life by individuals who reside in their midst.*¹⁰

Tolerance is that capacity for modification and adjustment – the fitting together of two pieces with room to breathe.

The city of Rome is an eloquent example of the responsiveness of brick and mortar to “territorial exigencies”. The brickwork of the Vatican City Wall was built over many centuries under the rule of

multiple Popes. And yet, it retains a level of coherence, each addition fitting in to the system by the variability of the joints. Repairs are made easily since they also follow this system of unit and binder. The masonry units are made of both stone and brick of varying dimensions, but they are all linked by the binding capacity of mortar. This dynamic persistence of the built object endows it with an almost biological resilience.

The introduction of robotic technologies is adding significant digits to the achievable dimensions of a built object. Glued brick panels can now be prefabricated off-site. In Harun Farocki’s film *Zum Vergleich*, the filmmaker captures a robot in Austria assembling clay blocks for partitions; another particularly famous example is the robotic arm R-O-B used by Swiss architects Gramazio and Kohler. This robot applies glue and lays bricks in complex patterns, generating beautifully expressive screen walls. Reyner Banham’s words of 1973 are becoming obsolete:

I repeat, machines are not all that accurate. They shed their accuracy with time, and furthermore, they must not be made all that accurate in the first place. We are in a civilization which depends heavily on interchangeable parts, and the basis of the



4.5. Mortar is used to accommodate changes in material.

4.6. The Vatican Wall system easily accepts anomalies.

*interchangeable part [...] is low finish, what is called "tolerance."*¹¹

The kind of crude, high-tolerance machinery to which Banham refers is being replaced with automated manipulation processes that can achieve both assembly and material tolerances in the fractions of a millimetre. Incompatibilities occur only when the two kinds of tolerance are not balanced. Bricks and mortar complement each other because the imperfections of the bricks are accommodated by the fluidity of the mortar, and the amorphous nature of the mortar is structured by the shape of the bricks. Using mortar, a mason can produce a plumb and level wall even with the most irregular bricks. In contrast, the R-O-B robot could not cope with industry standard bricks as these were not precise enough to be laid with glue; it requires precision-ground modules.¹²

The acceptance of anomalies is an intuitive process for any skilled worker, but in robotics, it is currently at the forefront of technological development. At the 2012 ACADIA conference, Volker Helm presented research from the ETH Zurich in the use of mobile robotic units on construction sites. Four digital "skills" were outlined: first, the ability of the robot to work with materials of varying dimensions. The robot was programmed to scan each layer

of modules and adjust all subsequent layers accordingly. Second was the scanning of human hand movements and gestures that would outline the robot's working area. Third was the recognition of its own position with respect to the construction. Using 3d scanning tags, it could reposition itself and continue working with the same pattern. Fourth, the fabrication of custom components to fit existing elements. The test used an integrated Styrofoam cutter and blocks were cut to fit exactly to given constraints.¹³

The success of these experiments depended on the integration of a 3d scanning tool with the robotic arm. The information obtained from 3d scanning technology could virtually eliminate the concept of tolerance in the construction workflow. Even error and material defects can be given highly precise dimensions which then affect the fabrication of subsequent components.

*Presently capable of capturing distances up to 6000m in radius (or more if launched from airborne positions) and generating 3D point clouds to an accuracy of less than 1mm, such tools offer unprecedented accuracy for the development and interrogation of design strategies before, during and post production.*¹⁴

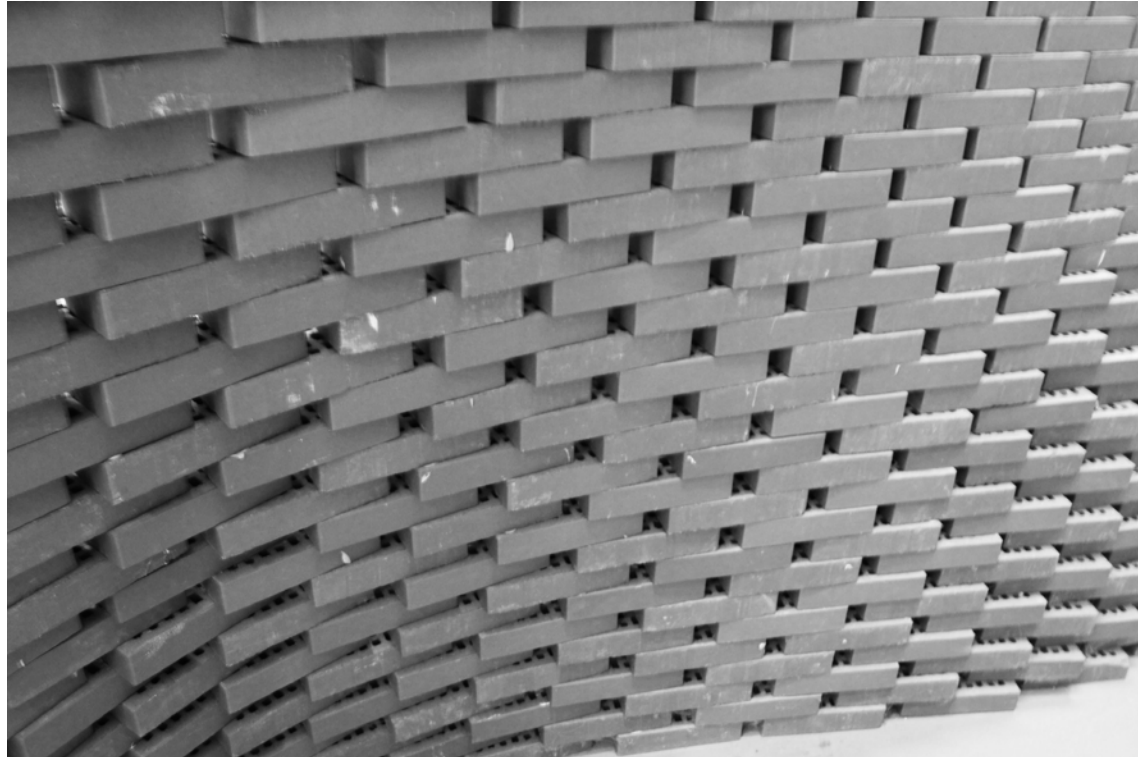

4.7. Wall laid by the ROB robot.

This immensely powerful capability will release robotic fabrication from its normal industrial context and extend its applicability even to renovations and restoration. With enough information, even qualitative observations can be codified, processed, and programmed. However, the “sublime dexterity and meticulous craft”¹⁵ made possible through robotic technology has the corollary of eliminating indeterminacy and improvisation.

Is the ideal world one in which a drone can scan a site, produce a topographic map to an accuracy of 1mm, and then feed the information into a robot that fabricates a building where every joint fits with the precision of a Swiss watch? Or is it better, perhaps, to have a slightly looser attitude, allowing for the interpenetration of building and site with a degree of slip? 3d scanning does not project or infer, it samples a condition at a particular point in time. It handles momentary given conditions but not future possibilities or even different states of the present. To do so would require multiple scans, perhaps continuous scanning, predicting future states based on present ones. As discussed previously, the amount of data required to be truly precise becomes too unwieldy to be useful. It is better to leave a certain amount of indeterminacy.

With digital fabrication, this indeterminacy must be imagined from the very beginning, so that its flexibility can be an integral part of either the manufactured component, in the case of prefabrication, or the computer program, in the case of on-site robotics. Consequently, the powers of the human mind are a necessity. The designer must be familiar with the qualitative and temporal aspects of a site, so that these intangible qualities can be translated into a language that is understood by machines.

It is possible that mortar will become obsolete, but flexible assembly between prefabricated units will remain necessary in the construction process. Architects need to design the gap between their components, a non-prescriptive gap that can be filled in and rendered meaningful by the place in which the components are installed. By providing and designing the space of tolerance, we can affirm the continued relevance of place and user in concordance with automatic construction.

It was hot and sunny the day I poured the slab that would be the foundation of the shelter. I had preassembled the formwork cut using the CNC router. Paul the gardener and I marched it across the field and laid it in the prepared hole. The flexibility of wood

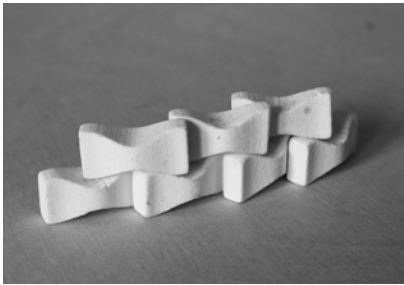

1



2

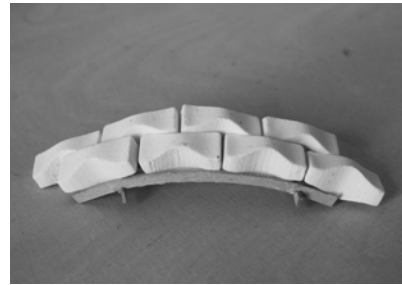

3

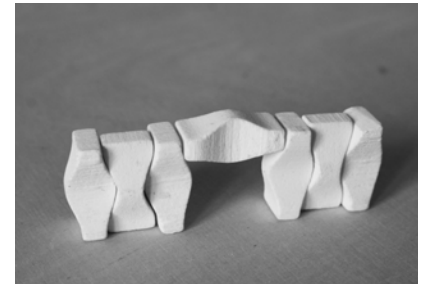

4

4.8. Assemblies used in the Terracott.

- 1 Wall 1
- 2 Wall 2
- 3 Roof
- 4 Floor



connections allowed it to rest evenly on the tamped clay. We filled the bottom with flint pieces left over from the clay excavation. On top we balanced the wire mesh, and then poured in the concrete. Just as we finished, the first drops of rain started to fall. We were soon packing up in a downpour. When I came back two days later to remove the formwork, I found the slab had absorbed some of the characteristics of its site. It had adopted its gentle slope to the south as well as its rain-pocked texture. The mortar under the first course of bricks compensated for the slope and filled in the rough surface.

The mortar joints in the Terracott are not simply extrusions of the face of one brick; instead, they have a form and identity that is particular to them. Each surface that I built required me to learn a new aspect of the craft of mortaring. Before I started, I thought I could make a tool that had the shape of the joint, place it on the brick, fill it with mortar, and then remove the mold. I made a prototype for one kind of bond and tested it. Although the tool did not fit every brick exactly, it seemed like it would be quite accurate. Then I started Wall 1. I realized that such a tool would never work

- 4.9. Pouring the slab.
- 4.10. Design for a mortar mold.
- 4.11. (opposite) Joint finishing.

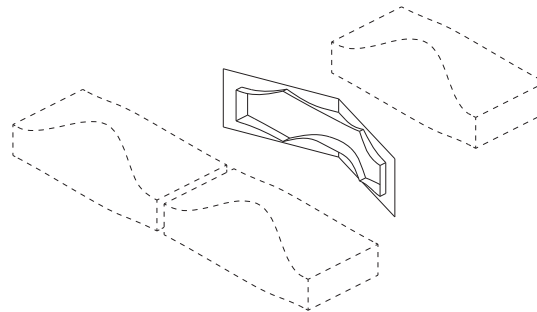



for this wall, because every brick is angled differently. I adapted the technique and instead used a partial frame. About halfway through the wall, I had a lesson with a bricklayer. He thought that my mortar mix was much too dry and that I was not using enough of it. He demonstrated that the bricks stick better and the joint is cleaner if a very wet mix is used, but left to dry before cleaning the joint. The mortar has to be generously applied so that it 'squishes' out with the pressure of the brick. I had to learn the correct amount of pressure to apply. Sometimes, I did not add enough mortar at the beginning, and I found I could barely place the brick before it was level with its neighbours. Other times, I needed a hammer to tap it down into place.

When I started Wall 2, I had decided not to use a mold, even though the joints in the wall were all of the same shape. Instead, I worked on my joint finishing technique. Following the advice of the bricklayer, I applied mortar and laid the bricks of an entire course before going back to clean up the joints. Both Wall 1 and Wall 2 are laid in patterns that reveal the thickness of the assembly. Although this was my intent, it meant that all sides of the joint would be visible. I developed a system where I had a tool in each hand, using whichever was most convenient for the side where I was working.

Mortaring the roof provided a different challenge. I had to prevent the mortar from dropping out the bottom of the open joint. I found that unfired clay was very useful for this task. When moist, it stuck to the brick and I could shape it by hand to fit the crevices between the pieces of the scaffolding. After a few days, it would dry and shrink away from its gap so I could collect the pieces for reuse. After discovering this system, I used it to make custom bricks that fit between the roof and the wall. I could bring the molding process to the site; the clay took on the exact shape of the gap, and then shrunk just enough during drying and firing that a thin layer of mortar could bond it back into place.

4.12. The bricklayer demonstrates the proper consistency for mortar.





4.13. Roof mortaring.

For the floor, I found a way to use the ‘belly’ of the brick to make a wedge-shaped joint. This joint was useful in two ways – it prevented the mortar from dropping, and locked the brick into place. The bricks interlock so that each one acts as a keystone for its neighbours. The mortar provides friction for this locking action. It is designed, just as any other connection or fastener is designed, but its advantage is that it can also accommodate variations in pattern, assembly angle, and module shape. Tolerance should not be the unfortunate result of two pieces that do not fit but should be a designed space – designed yet indeterminate.

4.14. Interlocking assemblies used for the floor of the Terracott.

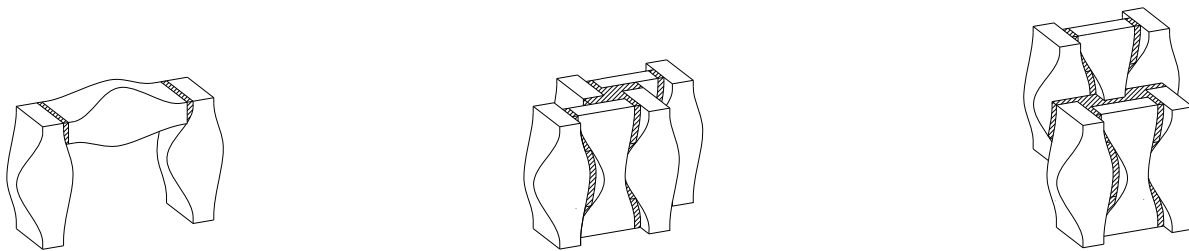



4.15. A Wall 2 joint.





Today, progress itself must be designed [...] Instead of adding ever-increasing layers of intricacy, specificity, and coordination, architects should question the complexity that dominates our buildings and lives.

–Kiel Moe¹

It is no longer enough for a building envelope to simply be solid and durable. There are increasing demands on its ability to control climate, adapt to changing environmental conditions, capture energy, etc. The typical response to these challenges has been a multiplication of systems and technical solutions, from the ubiquitous multi-layer wall to double-skin facades and photovoltaics. However, the shortcomings of these strategies are revealed when they are evaluated with consideration for the entire life cycle of material. For example, glass has over six times the embodied energy of brick.² If resource use is examined holistically, including material, energy, labour, and maintenance, it becomes clear that a simpler approach to construction will perform better overall. Performance could be defined as the capability of responding dynamically to external conditions. Achieving this responsiveness with a minimum of means is an approach that would increase the care used during design and construction. Within this approach, brick can affirm its



5.2. Overlapping tiles create a Catalan vault.

role as a vital and enduring construction material. With appropriate manufacturing methods and applications, it has the capacity to be part of the next generation of performative materials: an “intelligent mongrel of both the archaic and contemporary”.³

Eladio Dieste, the Uruguayan structural engineer, was a pioneer and an advocate for material economy in the design of brick structures. His constructions derive their elegance from the exploitation, as he



5.3. The Catalan vault at Grymsdyke Farm.

writes, of the “possibilities” of brick:

It is not enough to use brick because we like its texture and the fact that it is a material full of historical references. It is not that this is bad in and of itself, but we can take much better advantage of its possibilities. -Eladio Dieste⁴

The small modular forms of brick allow it to wrap around undulating geometry, a property that Dieste employs to create rigid structures from very thin shells. He uses the technique of Catalan vaulting (overlapping multiple layers of tiles) to achieve long spans and stiffness with minimal material. As well, brick vaults require less formwork than concrete since much of the matter comprising the vault is solid.

Despite the efficiency and advantages of this structural system, it has not been widely adapted for three main reasons. First is the economic necessity of flat floor plates, which limits its application. Second, it requires skilled labourers that need to be familiar with the system. Third, the geometries resist calculation and representation – two elements that have become necessary in an industry where design and construction are severed. To work around these limitations,

Dieste had to train his own workers, and he owned a construction company. He “worked outside of conventional regulations” to make his projects feasible.⁵ Today, advanced three-dimensional modelling could be used to bring this kind of vaulting into mainstream construction. For complex geometries, it quite possible to imagine that the engineer and builder would have a tablet with them on site containing the 3d model, which could be orbited, sectioned, dimensioned, and examined at will. The use of portable technology would also result in an economy of paper, with information being transmitted electronically and real-time from the office to the construction site.

Dieste’s work seems novel from the point of view of architecture, but the versatility of ceramic has long been known and exploited by the electronics, automotive, and aerospace industries. The properties of ceramic materials can be engineered for specific applications; they can be conductive or non-conductive, dense or porous, hard or ductile. If building ceramics could perform even the minutest fraction of the tasks that industrial ceramics perform today, they would be considered among the most technologically advanced architectural materials. The material research in brick, however, has mostly been focused on simply lowering the density of the

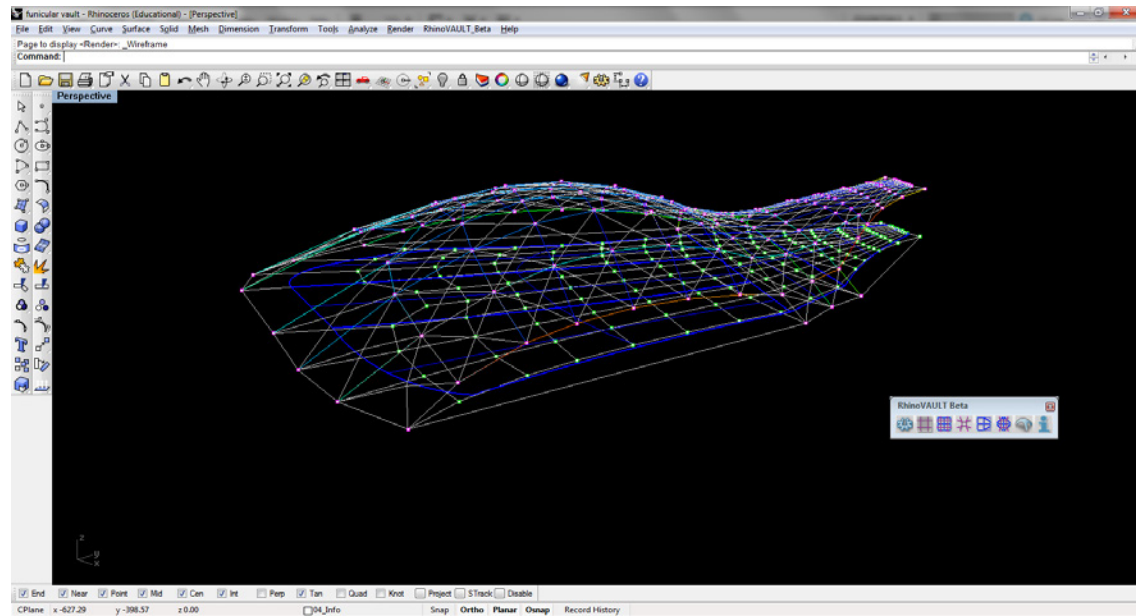

5.4. Screenshot from the RhinoVault catenary vault modelling plugin. Developed by Philip Block and teammates at the ETH Zurich, this script can be used to model compression-only vaulted structures.

substance. A less dense unit can be larger and still be handled by one worker, as well as having increased thermal insulation properties. Wienerberger, the world's largest clay brick and block supplier, is one of many companies that include sawdust as an additive in their insulating modules, which burns off during firing to produce small pores.⁶

Wienerberger is working to achieve a monolithic wall system. A wall comprised of a single layer and material would facilitate both the assembly and disassembly of buildings. In cold climates, though, the monolithic wall is not a viable option; as the density of the material is lowered, the wall must get thicker in order to compensate structurally. To achieve an adequate thermal insulation as well as structural strength, the thickness becomes prohibitive. Blocks of over 40cm thick are both unwieldy for the worker and inefficient in terms of space. Currently, the Porotherm block has a U-value of 0.31 w/m²k with a thickness of 36 cm.⁷

The manufacturing process of co-extrusion could be valuable for the development of the monolithic wall. This process is standard in the electronic industry and has been applied to bricks, but for aesthetic reasons. Facing bricks are produced using a higher quality

clay for the outside layer and a cheaper, lower quality clay for the inside. These two materials are extruded separately but bound together as they come out of the machines.⁸ If the two materials are chosen and modified so that their shrinkage is similar, they can be fused together before firing. Perhaps a multi-layer brick could be extruded, combining a structural layer with an insulating layer and a facing layer. To take this idea further, what if a brick could be extruded to include not only facade, insulation, and structure, but also a conductive layer for electricity distribution and hollow tubes for the passage of air or water? If the same base clay could be modified to have different shapes and properties, it is possible that the demands on the building envelope could once again be met by a single material. Both the material and the shape of the brick could be tailored to its situation and use.

Unlike Dieste, who uses the joints between standard rectangular modules to create larger curves, Alvar Aalto specified uniquely-shaped bricks to accommodate the geometry of his project for the House of Culture in Helsinki. Using a sculpted module, Aalto achieved walls with a very tight curvature. This module also had the advantage of containing an inherent radius; with a consistent joint, the brick would structure the emergence of a larger form. For Aalto,

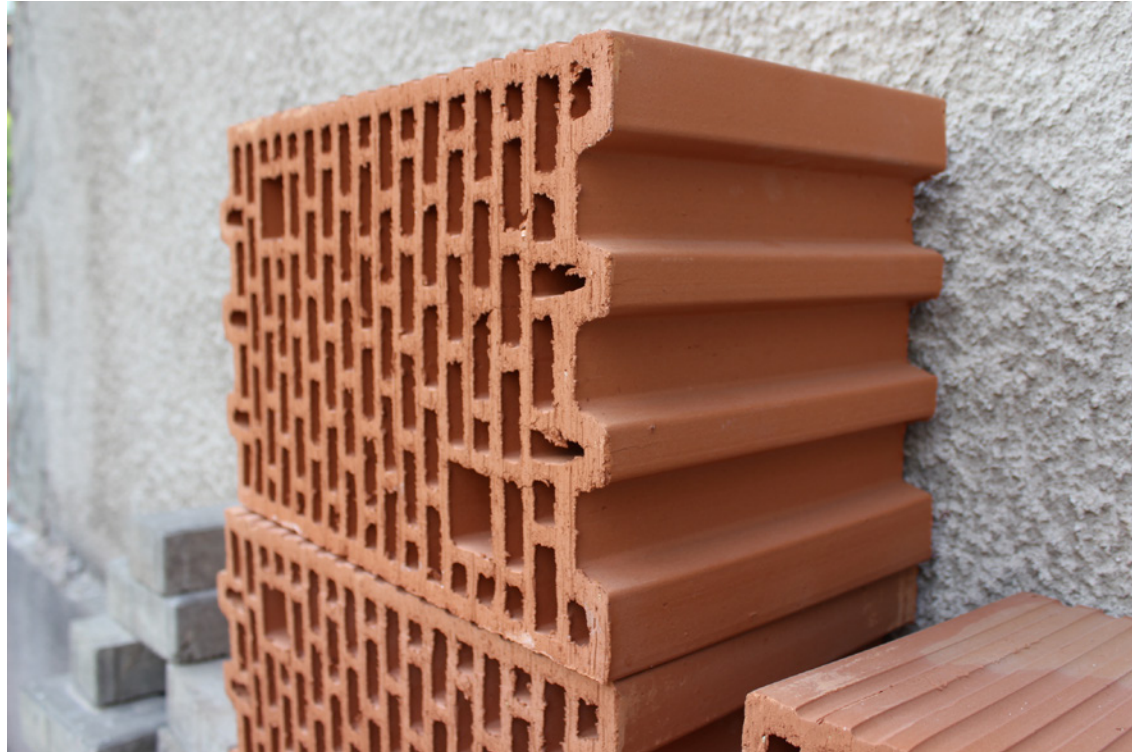

5.5. A Wienerberger Porotherm block.

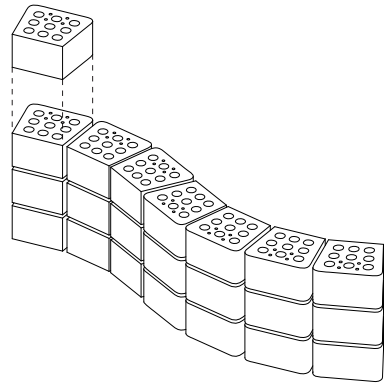

brick was an example of “flexible standardization”; like the cells of a plant, the modules adapt and combine fluidly to respond to external conditions.⁹ This concept is being developed today in the idea of “mass customization”.

Mass customization, both of the brick shape and the pattern in which it is laid, can increase the performance of brick in relation to its site. Existing industrial forming processes such as extrusion and wire cutting could be adapted for custom fabrication.¹⁰ Combining control over the speed of the extrusion and the angle of the wire would allow for great freedom in the resultant forms. It would, for

example, facilitate the creation of ‘self-shading’ masonry units for hot climates.¹¹ Wrinkles and deep indents in the units prevent them from absorbing the sun’s heat, allowing the interiors of buildings to remain cool. The use of daylight simulations allows these pockets to be optimized for the latitude and existing conditions. Similarly, the surfaces could also be designed to increase heat capture and storage in cold climates. One of the reasons for Aalto’s fascination with brick was its thermal retentive properties, important in the severe winters of Finland.¹²

Brick’s thermal mass regulates heat; the porosity of the assembly can modulate light and winds. Using rectilinear bricks twisted at incremental angles, Gramazio and Kohler Architects designed a performative facade for the Gantenbein winery in Fläsch, Switzerland. The advantages of the masonry screen are clearly described by the architects:

The masonry acts as a temperature buffer, as well filtering the sunlight for the fermentation room behind it. The bricks are offset so that daylight penetrates the hall through the gaps between the bricks. Direct sunlight, which would have a detrimental effect on the fermentation, is however excluded.¹³

5.6. The brick designed by Alvar Aalto for the House of Culture has skewed sides that imply a curve radius.

5.7. (opposite) The sun-filtering screen of the Gantenbein winery.



Although the pattern does perform in this way, specific environmental responsiveness was sacrificed in favour of an image that would be legible from a distance. An image of stylized grapes was used to determine the exact placement of the bricks. A brick screen, however, offers the flexibility to incorporate site data such as prevailing winds, sun, and views.

The facade panels for the winery were preassembled by the R-O-B robotic arm and installed using a crane on site. This system still requires improvement, since prefabricated panels negate many of the advantages achieved by using bricks. Smaller units require less on-site machinery. These units can be packaged tightly and efficiently for transport and then deployed on the site. The robot itself is housed in a shipping container, so it would be possible to combine the potentials of robotic assembly with the efficiency of small modular construction. In fact, the architects quote the mobility of R-O-B as one of its key innovations. They envision using the robot as a tool to work on site and with local materials.¹⁴

Small modular construction processes must also take into account the way in which the modules will be joined. For the winery facade, synthetic adhesive was used, providing a structural joint that allowed

the panels to be lifted after assembly. However, stronger joints are not necessarily better. In Warsaw, it was possible to rebuild the city only because many bricks could be salvaged from the rubble, something that could no longer happen due to the widespread use of cement-based mortar and synthetic adhesives. If performance also incorporates the ability of the material to be recycled and reused, the prevalence of cement mortar must be reconsidered. Any research in brick should happen concurrently with research in mortar and other joinery.

Automated fabrication is one way of achieving performance, but it must not be forgotten that there is no tool more adaptable or versatile than the human hand. Its potential has been largely forgotten, quashed by the prescriptive processes of construction that currently dominate the industry and privilege quantity over quality. Using less material, layers, and technical systems would refocus architecture on the craft of assembly. Some of the costs saved could be re-invested to improve the quality of construction and the skill of the worker.

When I arrived at Grymsdyke Farm, I had in my mind the work of these masters of brick and the performance achieved by their respective uses. I had participated in a workshop where we began

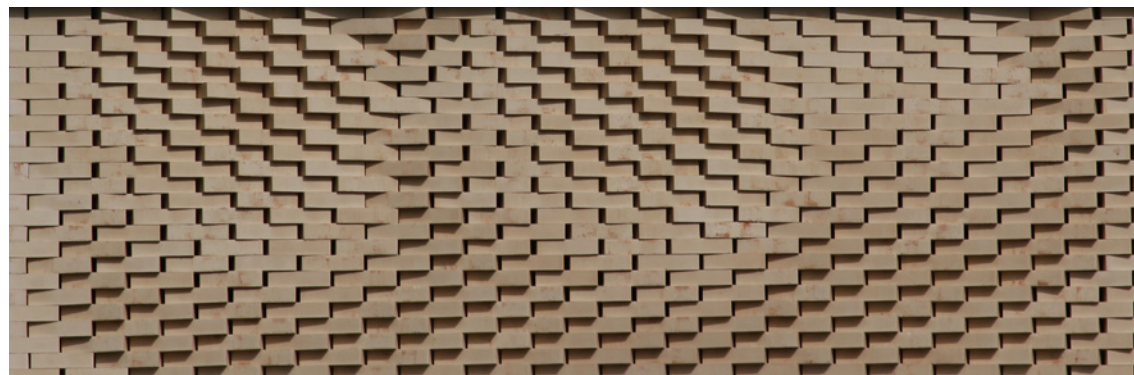
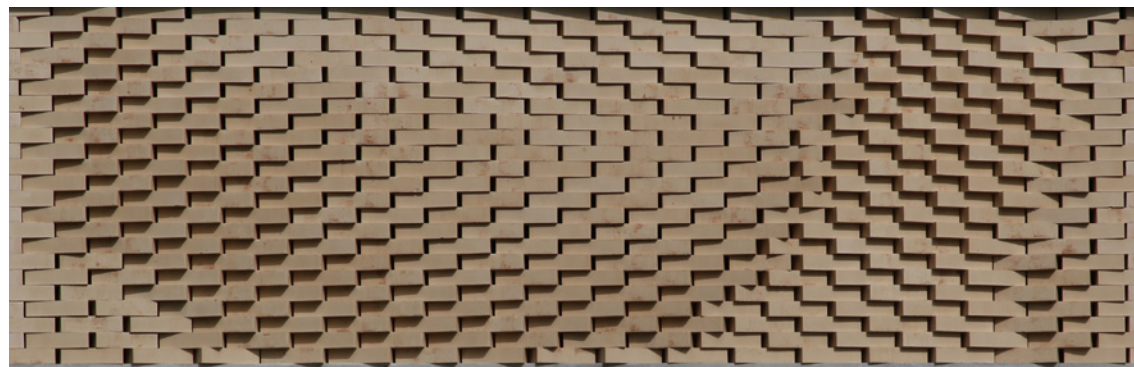
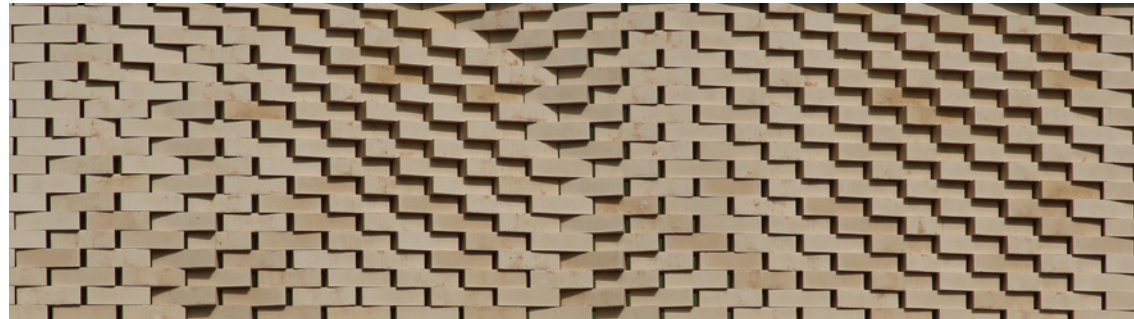

5.8. The Gantenbein winery facade patterns.

exploring brick's structural performance, using, like Dieste, the technique of Catalan vaulting. We created an ascent that achieved maximum strength with minimum material, both for the vault and for its formwork. This was the first trial of firing the clay from the ground. I returned to the farm because I felt that I should continue exploring the possibilities of this versatile material. I wanted to construct something that would take advantage of the heat and light capturing qualities of terra cotta, as well as experiment with the performance of a non-standard module. I decided to construct a shelter that worked on the principle of the Chinese *kang*, or stove-bed: a brick sleeping surface that also acts as a fireplace flue. As hot air moves underneath the surface towards the chimney, it warms the thermal mass of the brick.

Material economy was an absolute necessity. I was the only labourer for the project, and I had to sort and process every kilogram of clay that I used. The practicality of a lean module was further reinforced by the reduced drying time. I tested some modules with holes, but the forming process proved too complicated to be viable. The desire to reduce the amount of material as well as provide a way of interlocking the assemblies led to the concept of a notch. Taking this idea as a basis, I produced many iterations of modules, which

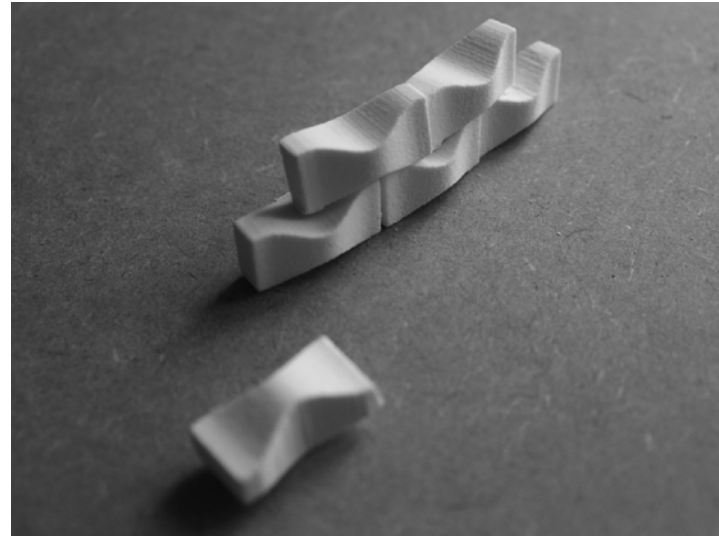

5.9. The chosen module.

I tested using the farm's 3d printer. Manipulation of the scaled modules allowed me to test assemblies, geometries, and appearances. This physical interaction was of utmost importance. It was very hard to evaluate the modules on the screen, because they were not affected by laws of physics and materiality. I would often place modules so they were floating in space or so they were penetrating each other. I also understood Dieste's frustration with two-dimensional

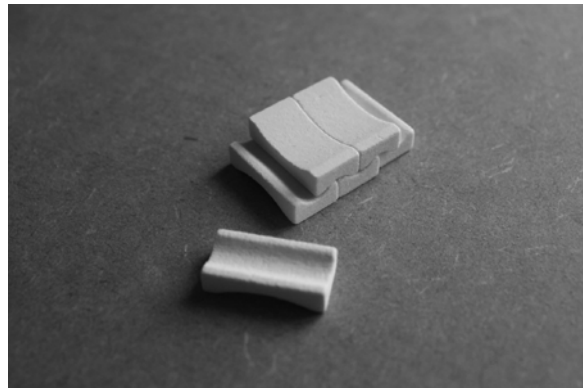
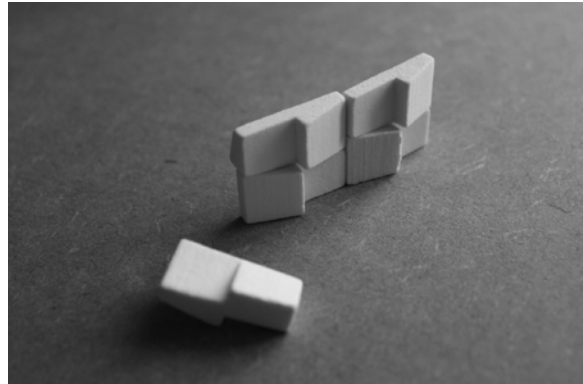

5.10. 3d printed module iterations

representation¹⁵, for neither the module or the pavilion shape were easily adapted to a flat plane. Instead, I worked extensively with the digital and physical models, as well as testing mock-ups of the pavilion shape at full scale in its site.

I took some time to decide on the final shape of the module. Even after I had chosen a basic concept – a curve in plan, and its inverse in elevation – there were many small decisions to be made. I wanted it to be an interesting object, assemble in multiple different ways, and somehow imply a larger geometry. This last criteria proved to be the most difficult; I ended up abandoning it. Any larger geometry (such as a curve radius) resulted in such a small skew of the individual unit that, accounting for tolerances in forming, drying, and firing, it would probably be unnoticeable. As well, building an inherent geometry into the brick removes a lot of the flexibility that a more generic module has. The final module is symmetrical in all axes. This allows a greater freedom of assembly, since flipping or inverting the module does not affect its geometry. It is fairly even in thickness throughout its length, which eases the processes of drying and firing. The curvature increases the apparent size of the module while minimizing its use of material. It can be assembled either very densely, or very loosely, depending on its orientation and placement.

Finally, the unusual form is intriguing both on its own and in combination. As I proceeded with construction, I discovered other benefits that I had not predicted, such as the way it comfortably fit in my hand.

Constructing solo really sharpened my sense of the value of material and labour, and revealed the necessity of being as simple as possible. The shape of the shelter was derived from these preoccupations. The minimum amount of sides needed to enclose a space is three; therefore a roughly triangular plan was chosen. A curved wall adds rigidity with only minimum added material. A vaulted roof can take the place of some of the wall. The dimensions were chosen roughly based on my length when lying down. The offset bonding patterns, as well as providing depth and modulating light and views, permitted less bricks to cover more surface area. All of these decisions, however, did not manifest themselves as restrictions, but instead as opportunities to express architecture in its essence: as the product of human interactions with nature. To perform is to respond efficiently and eloquently to the exigencies of construction.

5.11. The bricks are assembled to create a permeable screen.







A brick is both generic and unique. Its usefulness as a building material depends on its existence as one of a multitude of similar objects. Yet the material inconsistencies of clay, the action of weathering forces and the association of the material with events in individual and collective memory all contribute to the distinction of one brick from another. All three of these forces register themselves in the substance of the object. The first two have obvious material implications. The third is not so evident, but it is perhaps the most powerful. It can determine whether a wall or building is maintained, ignored, or demolished.

For example, take two walls in Warsaw, Poland. Both are ruined. Both are built out of red brick, the outside surface of which is darkened by grime, soot, and moss. Both have mortar joints that crumble into dust when touched. But one is neglected, and one is kept meticulously preserved in its ruined state. The reason for this difference is found only in the history of the city and the memories of its inhabitants.

Arriving as an outsider in Warsaw, I found the different attitudes towards similar built objects both confusing and intriguing. At different points in the city's history, brick has represented opposing

concepts: freedom and oppression, solidity and ruin, humanization and monotony, and legislation and self-organization. It was appropriated by different groups under different guises: as an icon, as an item, and as a record of labour and energy. As such, Warsaw is an ideal case study to explore the spectrum of ways in which invisible values can affect visible constructions; more specifically, how brick can acquire meaning.

I spoke with some of the city's street artists in order to gain a current perspective of brick that challenged the usual concepts of value. A graffiti artist and an architect perceive a city from inverse perspectives. To an architect, walls indicate interior, contained spaces, and owe their existence to an overarching order. The graffiti artist understands the logic of walls from their physical appearance – their texture, size, and relationships – as well as their importance in the minds of local inhabitants. The position of a piece of street art must be carefully considered, since there is the possibility of legal consequences or immediate erasure.

During a conversation with a street artist, he told me that for him, there is a distinction between “new” brick - perhaps mixed with concrete block, generally poorly executed - and “old” brick, solid



6.2. Ulica Waliców 14. I revisited this abandoned tenement often.

and noble, “a hundred years old or more”. He would not dream of painting on “old” brick: “To me, this wall has soul”. In Warsaw, however, these classifications are meaningless, since the city was almost entirely rebuilt in the 1950s and many of the old buildings that remain are regarded as slums and worthless ruins. Nazi forces deliberately destroyed the city in 1944; 85% of its buildings were reduced to rubble.¹ Instead of aerial bombing, charges of explosives were placed at key points of the most important structures to ensure their complete collapse.² After the retreat of the hostile army, returning Poles spontaneously organized themselves to salvage bricks from the rubble and to begin rebuilding.³ For this task, the generic nature of brick was essential. As a modular unit of a size that can easily be handled by one worker, and as discrete blocks that could be salvaged from the wreckage, brick allowed all citizens to contribute their labour to the reconstruction. It is perhaps this expression of work and care, and not the actual age of the wall, that imparts it with “soul”.

Warsaw’s Old Town has the charm and kitsch to rival any other medieval European burgh. The red brick city walls are a favourite place for tourists and locals, where they can catch some sun and eat *lody*, ice cream. Only after long observation do the artfully ruined

walls start to appear slightly strange, slightly too perfectly crumbled, capped with new brick to provide ideal places for sunbathing. In fact, the wall was rebuilt in the 1950s using bricks recovered from the surrounding area. Large Gothic-era bricks are mixed with smaller, newer ones. The various ages, sizes, and states of the bricks creates a mottled texture that adds depth and interest to the wall. The entire Old Town is a source of pride for Varsovians. Despite having been reconstructed barely 60 years ago, it has earned the status of Unesco World Heritage site.⁴

The celebration of the citizen-led reconstruction conceals the political climate of that time. The Soviet government, which had taken power after the war, saw in the spontaneous rebuilding efforts a



6.3. The Old Town Wall, Warsaw. Broken bricks recovered from the rubble are laid chipped side out for added texture and colour.



6.4. Plac Zamkowy, the main square at the entrance to Warsaw's Old Town.

chance to gain legitimacy and acceptance among the Polish people.⁵ They adopted an ambitious six-year plan for the reconstruction of Warsaw. The shortage of building materials available after the war, coupled with the ambitious schedule for reconstruction, resulted in an artificial inflation of the economic value of brick.⁶ The collection, donation, and construction of bricks became a nationally organized activity. Warsaw was meant to act as a showcase of Communist Poland; as such, all resources went towards the capital. In lesser cities such as Wrocław, for example, many buildings with only minimal damage were deconstructed to send bricks to the capital.⁷

The Soviets permitted sentimentality to dictate the reconstruction of the Old Town. In other parts of Warsaw, they razed what was left of the city to create monumental squares and boulevards.⁸ These were designed in their chosen style of Social Realism, which made use of applied ornament as propaganda to forward the interests of the Party. Choosing the iconic properties of sculpture instead of the subtler, indexical nature of the brick walls, they immortalized the bricklayer in oversized statues while hiding his work beneath panels of stone. The nature of communist labour privileged quantity over quality, and the fastest teams of bricklayers were praised in public ceremonies.

The district of Praga, on the opposite bank of the Vistula river from the medieval city, was not touched either by the Nazis or by the Soviets. Its collection of basic brick tenement buildings and factories was not deemed of enough cultural importance to merit destruction during the war.⁹ After the war, the Soviets left the neighbourhood because the sparse efficiency of the buildings aligned well with their Communist ideals.¹⁰ Today, Praga's tenements are caught in a stalemate between the municipality, developers, and residents.¹¹ Their physical reality is often deplorable. The courtyards receive very little light, and the uninsulated brick walls are an energy drain in the cold Polish climate. If the brick was covered by a layer of render, the crumbling plaster reveals sloppily executed construction, and if brick was also used for facing, it spalls. Often, a skirt of netting is suspended just above ground level to prevent the pieces from dropping on unsuspecting pedestrians. These conditions have led to the perception of these tenements as slums: a perception that is linked to their material. However, Praga is the only district where so much of the pre-war fabric is left intact. The municipality wishes to preserve the apartments as heritage buildings, but has no funds to maintain them, whereas developers are seeking to revitalize the area, which received much attention during the hosting of the 2012 Euro Cup.¹²



6.5. Statue of a bricklayer on a Social Realist building.

Community street art projects in Praga quietly protest both uninhibited gentrification and the apathy that currently afflicts the residents. The neighbourhood's underprivileged youth work in collaboration with established artists to create murals. This action reconnects the youths with their environment and creates landmarks affirming the existence of life in this half-deserted cityscape.

Unlike the tenements, the factories in Praga were durably constructed and maintained, out of necessity, by their respective companies. As a result, some of the most poignant spaces of Warsaw's industrial heritage are crafted of finely detailed brick. Some of these remain abandoned, but the high quality of construction has made them targets for developers seeking to market their raw aesthetic for loft living and cultural events. Brick, in this case, increases their value. The adaptive reuse of industrial brick buildings has become internationally fashionable; the conversion of the Bankside power station in London into the Tate Modern gallery is a well-known example. In Praga, the Koneser vodka factory is currently the site of a €97.8 million investment to convert it into a complex with "centres of culture, luxury lofts, modern office buildings and retail and service premises".¹³ In its present state, though, partially demolished, mostly abandoned, it is already a small cultural node. A theatre and gallery



6.6. Provisional solutions to crumbling brick.



6.7. The Koneser factory.

occupy two different buildings on the site; a third houses a small Museum of Praga. These independent operations will most likely not survive the renovation and its corresponding increase in rent. The museum will move to a nearby renovated tenement complex – plastered white to hide the brick construction.

The Koneser factory is being reused whole, as a building. The Old Town reconstruction made use of whole reclaimed bricks. A different level of reuse happened in the district of Muranow. Since this district was the location of the Jewish Ghetto during the Second World War, it was attacked multiple times.¹⁴ At the end, its devastation was so complete that whole brick recovery was impossible.¹⁵ Instead, brick pieces were used as an aggregate in concrete for the construction of new apartment blocks. Despite efforts at reuse and recycling, the sheer volume of material in Warsaw after the war meant that most bricks ended up as landfill. In the parks, the paths are studded with buried pieces. The streets are built on a bed of crushed brick. Although the surface is smoothed out with asphalt, plaster, or grass, this skin is often worn away to reveal the red underbelly of the city.

In a place that is so saturated with brick that it even forms the ground, it is surprising that this material still has importance as an icon. Yet

collapsing brick is used as a symbol of the Warsaw Uprising – the civilian-led counterattack against the city’s Nazi occupiers in 1944. At that time, partially collapsed brick walls were a daily reality for Varsovians, since their city was damaged by successive attacks and air raids. Today, it is cast in metal, drawn as an image, or arranged to mimic a ruin, acting as memorials to the Poles’ fight for freedom.

6.8. A fragment of crushed-brick concrete from the Muranów district





6.9. Warsaw's red underbelly.

Brick's power as an icon also permeates street art culture. Physically, brick resists the work of street artists. It absorbs much more paint than concrete or plaster, and it fragments the reading of the image. However, it is this very resistance that increases its popularity as a symbol. Many artists will paint a backdrop of brick onto a smooth surface before applying their design. It is the *raison d'être* of a graffiti artist to paint on walls, to take the city as a canvas, to provoke a reevaluation of a surface. The pattern of brick immediately directs the mind towards the idea of wall and therefore to the artist's transgressive relationship to it.

Return to the example of the two walls. They are both found in Warsaw's Midtown, a neighbourhood where new skyscrapers and office towers are being built amongst ruins left from the war. Similar to Praga, most of the remaining pre-war constructions are brick tenement houses. One fragment of tenement wall is treated with the utmost care and respect. Instead of broken glass and plastic bags, its base is strewn with candles and flowers. It has become precious to the point of becoming a relic, for the simple reason that it once marked the border of the Jewish Ghetto. Mr. J., who lives in an apartment just beside the memorial, keeps scrapbooks of the visitors who come to pay their respects. He says that many Jewish tour groups come,



6.10. Brick sculpted in metal at the Monument to the Warsaw Uprising.

as well as individuals who pray or leave tokens. Some of the bricks in the wall have been removed for installation in Jewish historical museums around the world. The fastidious maintenance of this piece of wall, from the outside, appears quite arbitrary. When viewed from the perspective of the Jewish people, it becomes necessary for the transmission of memory. It is important for them to relate the suffering of their ancestors to physical material. At the time of my first visit to this memorial, I was interested in collecting fragments of brick. I found none there – unusual for such a damaged surface.



6.1.1. Graffiti with a brick backdrop.

The wall had been picked clean by pilgrims. The bricks of this wall are both specific and symbolic: they come from a particular place, yet they represent the persecution and loss of freedom experienced by the entire Jewish population during the Holocaust.

The second wall, although ruined and ignored, is not entirely abandoned. It has become the location of a large mural. Facing a gravel parking lot, surrounded by apartment towers, the brick wall was painted entirely white with the words 'kamien i co'. I only later realized the subtlety and irony of the artists' work. The words are a pun: taken together, kamienico means 'apartment house', and separated, the phrase becomes 'stone and what'. The question sums up the ambiguous role of brick in the city.

Bricks are archaeological records of a city's evolution. The destruction of the city in 1944 unexpectedly benefited archaeologists and historians by exposing parts of buildings that had been subsumed by centuries of accreted constructions. Warsaw's Gothic persona and subsequent growth could be inferred by making detailed measurements, down to the millimetre, of the bricks in a particular wall. Using a graphic tool to map and compare sizes of bricks, historians identified which walls were constructed at the same

time, using bricks from the same yard, and which bricks had been reused from previous constructions.¹⁶ Today, brick is again a primary medium of construction in Warsaw, but it takes the form of large insulating clay modules that infill a poured concrete frame. Every construction site I visited had multiple pallets of Porotherm blocks. Poland is affirming its participation in the European and global markets; the strong presence of international companies such as Wienerberger proves this fact. Although made from local clay, the blocks are made to standard shapes and sizes.¹⁷ They are then covered with exterior insulation and cladding. Future archaeologists will perhaps identify Poland's liberation from Communism by the proliferation of internationally standardized bricks.

6.12. Porotherm blocks.





6.13. Bricks removed from the Jewish Ghetto wall are placed in museums around the world.

Warsaw's brick sublayer is unusually dense with meanings. However, consciously or unconsciously, human society is always preserved in the minerals it produces. Not just the soil of one city but the composition of the Earth's crust and atmosphere are subject to human influence. If we relate the scale of our actions to the scale of our senses, we will understand better the interdependency between us and our environment. Terra cotta, as a form of metamorphic rock, is evidence of humanity's capacity to control geological forces. Yet a brick can easily be grasped both literally and conceptually.

Bricks are a base unit of culture. They encode information and communicate it through their substance. Unlike the binary bits of digital information, they have infinite states. Each one alone is simple. In quantity they can build walls, buildings, cities, civilizations. With this humility and this power, they embody the diversity and subtlety of human experience.

6.14. (opposite) "Stone and What": Mural at Ulica Waliców 14







It starts with gravity. Or rather, continues. Gravity causes the accumulation of clay. It is the force that drives the process of disintegration, but also the processes of sedimentation and metamorphosis.

Building the Terracott was a careful dance with gravity. There were times when I would hate this relentless force: when I had to carry yet another bucket of clay, or when the mortar kept dropping out, or when the bricks started to slide down the slope of the scaffolding. But it is through the work of gravity that the shelter stands, solidly compressed by its own weight.

Sometimes, it seems like gravity is the enemy of architects. They design installations to be suspended with fishing line. They try to create the impression of floating planes and weightless boxes. This effort to conceal the physical force of gravity also indicates a reluctance to interact with the true gravity of construction's impact on the earth – gravity in the sense of depth and extent.

The Terracott is my attempt to engage the entire construction process. I wanted to determine how architectural problem-solving could be applied to all phases of a building's life. I wanted to understand the material transformations that shape the world. When I look at it now, I see the result of my physical and mental effort to address these issues.

I see its flaws. I could have designed a better intersection between the walls and floor. I had to chip some bricks to make them fit. The mortar stained the fired clay. I forgot to come back and strike off a joint before it set. The courses do not exactly align. I remember the frustration and the exhaustion, the times where I would fling myself onto the grass and question why I was even trying.

Then, I remember the small triumphs. I remember the pride of a well-struck joint. I remember removing the scaffolding from the roof and standing under the vault for the first time. I see the difference in quality between the first batch of bricks that I made and the last. I remember opening the kiln and holding a new brick, still warm. I remember seeing

the smoke come out of the chimney for the first time, knowing that hot air from the fire was being drawn under the floor and up. And now, I wake up in the home that I have built.

I walk on the path I have worn through the field. Instead of a load of bricks, my trowel or the ladder, this time I carry only firewood and matches. The sun is setting in the opposite corner of the field. It casts its light on the bricks, sharpening their shadows and intensifying their orange colour. The wood is dry. The flames catch quickly, and I rejoice to see the thin plume of smoke trailing from the chimney. Later that night, when the fire has burned down, the bricks retain its heat. In the cooler night air I try to press myself closer to the surface. My hands reach for the material again; this time not to form or place it but to feel how this building's warm skin relates to my own.

In the Terracott, the mass of the bricks complements the lightness of fire. The bricks absorb heat; the fire remains sheltered. In the same way, the lightness of design and digital work benefits from a pairing with

the physical weight of material. The first addresses the inspiration of architecture, the second its gravity.

Gravity is a constraint, but it is also an anchor. It is a constant, dependable force that can be understood. And understanding leads to inspiration. To inspire is to draw in breath; it is a gathering of substance into the body. When a profound understanding of existing conditions is gathered into the mind, the potentials of the situation are revealed. For this reason, despite all of my mistakes, I could not have worked any differently. I was testing my capabilities and the capabilities of the material. Inevitably, adjustments had to be made. My failures allowed me to acquire a material intuition that I can now use to inform future designs.

From the Terracott, I have learned to design without taking anything for granted – to connect every gesture to its origin and its outcome. To know the environmental, cultural, and physical weight of material, and to make it my inspiration.





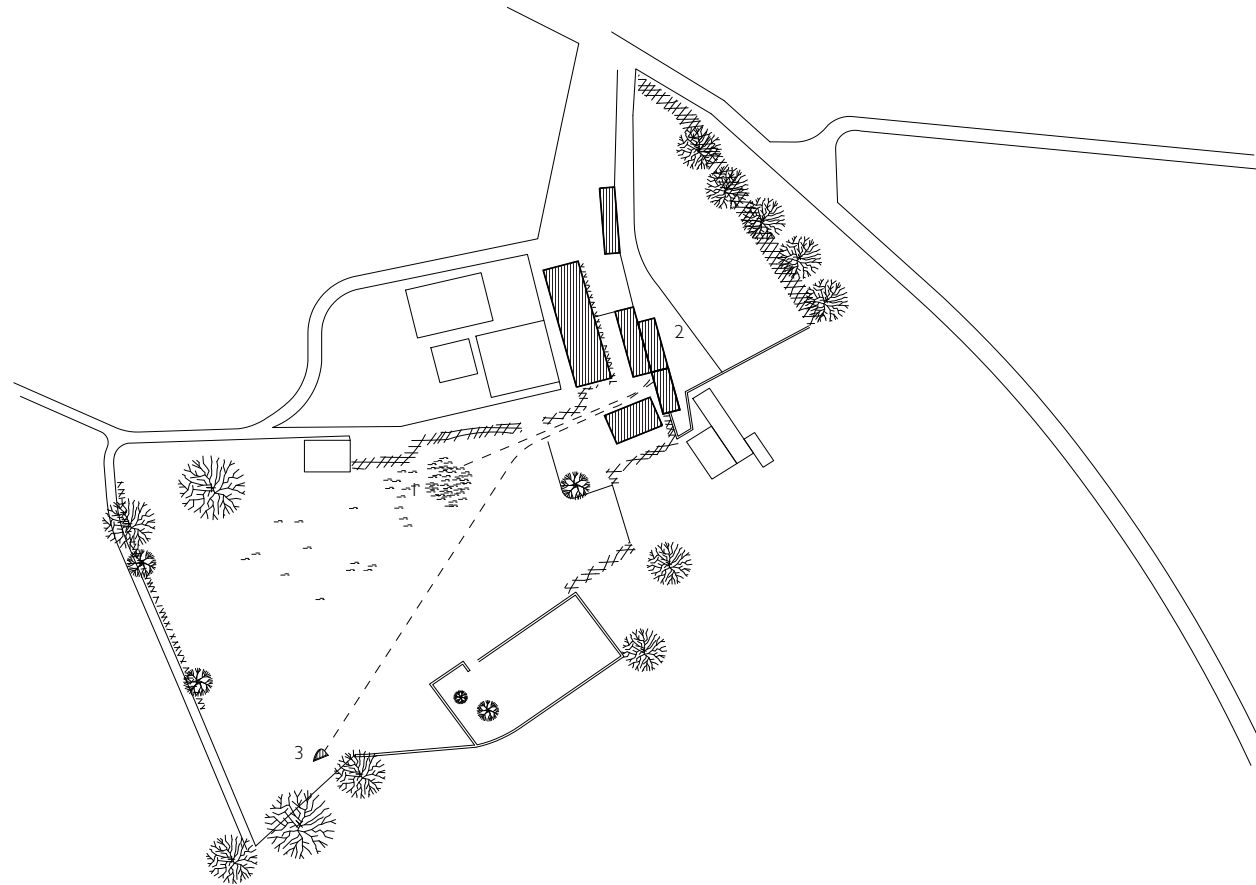

Site Plan 
1:2000

- 1 The clay source
- 2 The workshop
- 3 The construction site





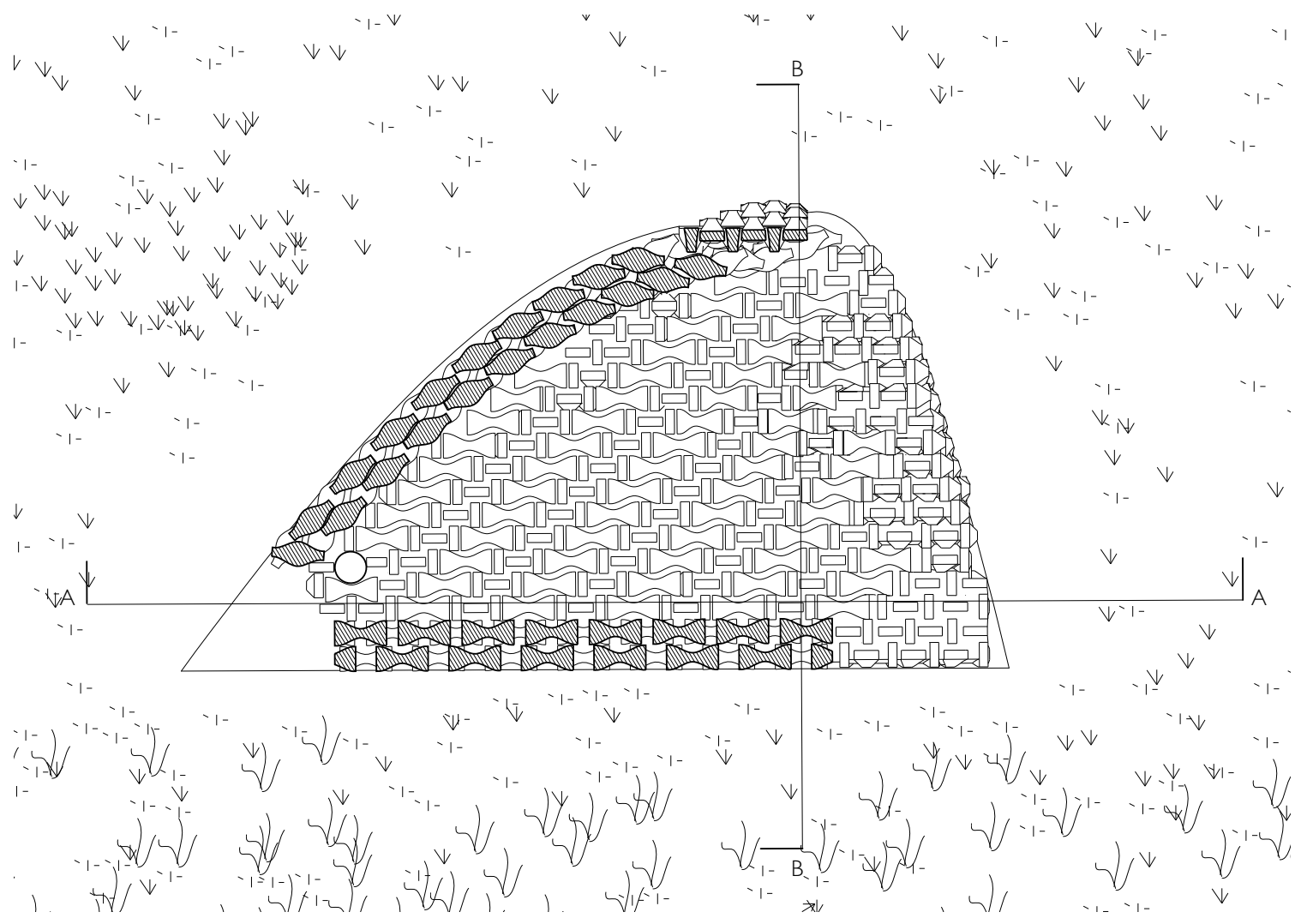

Plan
1:25



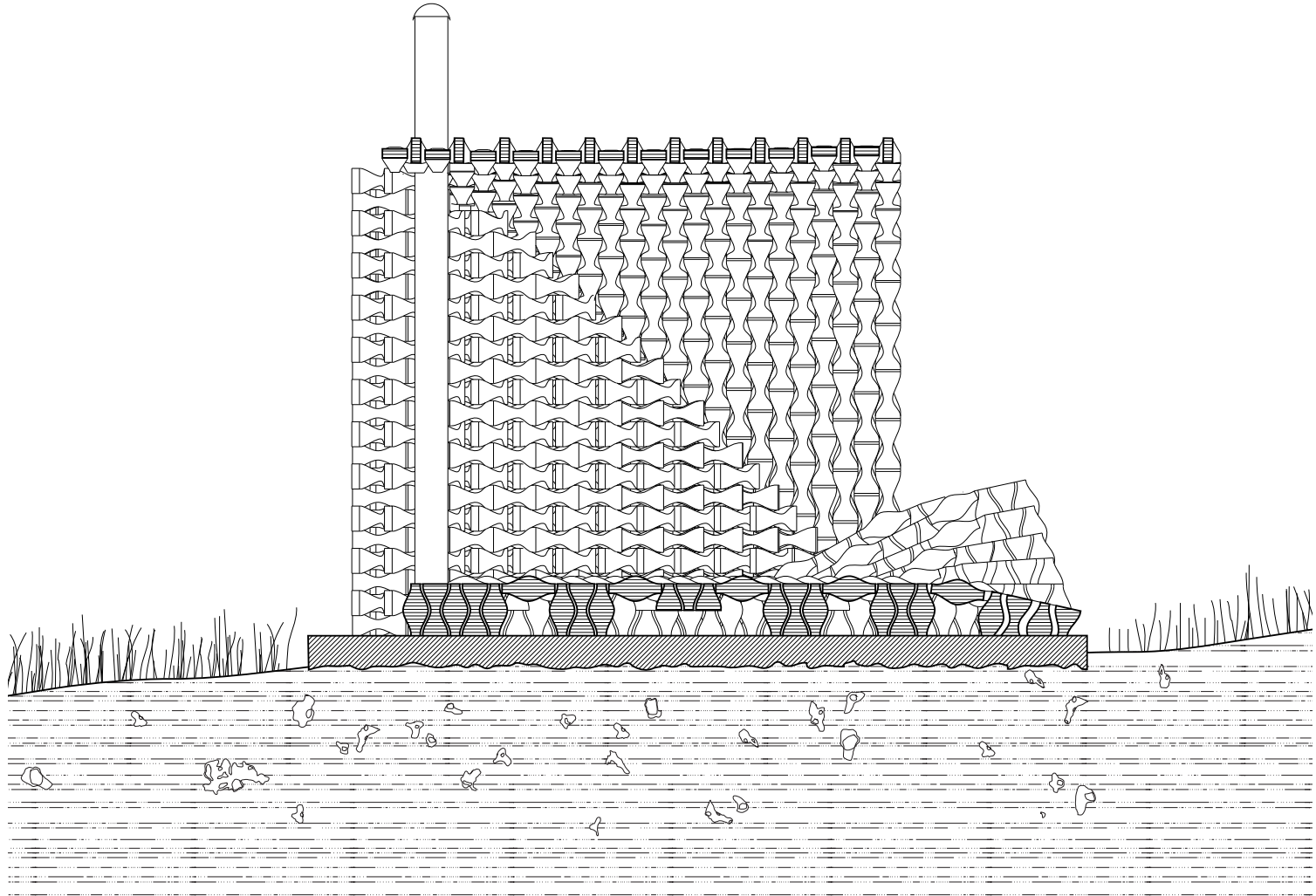

Section A
1:25





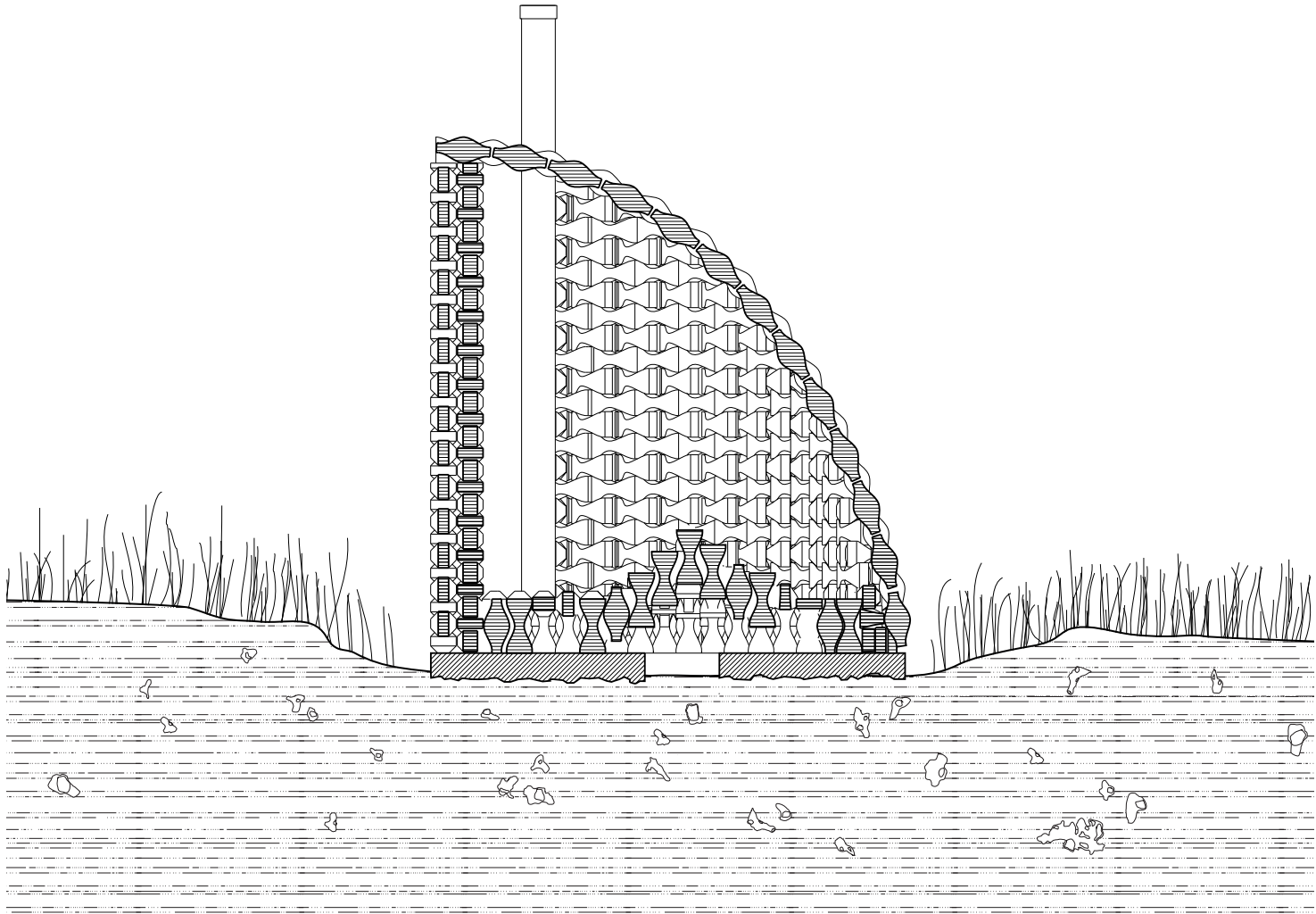

Section B
1:25









Brick today is generally understood in one of two ways: as a surface with aesthetic properties, or as a volume with structural properties. However, if the material is taken to have not only spatial implications but temporal ones, its potential for architecture increases exponentially. Adding the dimension of time to the understanding of brick – either through its manufacture, its assembly, its performance, or its eventual disintegration – is equally applicable at the scale of a small prototype such as the Terracott and the scale of the entire industry. Brick's material properties can address changing conditions of light, heat, and moisture. Its metamorphosis, instead of being driven by temperature only, could perhaps be achieved with a combination of temperature, pressure, and time. Through its shape, it can imply or facilitate certain methods of assembly and transport. Its design can acknowledge the worker or machine that will handle it. Once laid, it can direct weathering patterns. It can influence the behaviours and memories of the people who design it, built it and experience it. These properties are just some of the ways that the duration of brick can be purposefully designed.

If brick can offer to construction its ability to react over time, then construction can offer to brick the technology and techniques to make this dynamism possible. Research and development have created

options. Bonding can be more than just stacking. The bonding agent does not have to be mortar. The clay can be mixed with additives that change its properties. A fluid interaction between information and a material response to that information is now achievable.

In this scenario, handcraft would be evaluated as one of many options, with strengths and weaknesses that make it more suitable for certain situations than for others. As well, with the increasing portability and flexibility of automatic tools, it will be possible to use hybrid methods of construction that make use of machines for repetitive tasks and allow the worker to concentrate on details and joints. Ideally, neither machine nor hand is used as an end in itself. Instead, they are techniques that produce certain outcomes in the material.

In any case, the intervention of the human mind is necessary for the selection of the tool and the desired outcome. Human intelligence can holistically grasp the ensemble of conditions to which a built project must respond – conditions that affect the choice of technique. Without the mind's ability to synthesize and evaluate information, the relationship between tool and material would quickly become redundant. This ability to address a situation holistically differentiates

architectural research from other disciplines such as material science. Brick is not just a substance with certain properties; it has meaning and value. It is associated with concepts that might have very little to do with its reality. It is the task of the architect to know all the levels at which a material operates to therefore use it to its best advantage.

How, then, can one get to know a material? I started with this question at the very beginning of the thesis, when I had the entire city of Rome to explore. I chose to conduct my research empirically. I decided that it would be my experience and my body that would be the mediators of my discoveries. Indeed, every picture in this book is one that I have drawn or taken myself. This method lends specificity and legitimacy to the challenges of working with material. Architecture is incredibly complex; no amount of information can fully convey all the nuances that make up our lived reality. A large percentage of what I learned is not transcribed, but is preserved in the associations of my mind and the skills of my hands. This intangible knowledge, however, profoundly affected the lasting outcomes of my work: this text, and the building.

Embodied knowledge is often undervalued for the simple reason that it cannot be shared. It can be proven or demonstrated, but it

always belongs only to the person whose experience it is. For me, film was a way of making my experience accessible to others. It is still only a shallow summary of what actually took place. A more revealing experience would be to go to Grymsdyke Farm and stay a night in the Terracott. This is why embodied knowledge is essential to the practice of architecture: architecture will, in turn, influence the embodied knowledge of its inhabitants.

The dynamic variability of brick could be understood as the embodied knowledge of the material. Just as each person's experiences are different, every instance of a material has the potential to embody different knowledge. For this reason, the specific qualities of the Terracott brick belong to that place and that building. The research interests, such as material economy, depth of assembly, thermal mass, and localization, could be more generally applied. However, architectural research should also address the interchange between human and material embodied knowledge. By treating research not only as technical experimentation but also as a study of culture, labour, and place, research and practice become integrated. Both affirm the value of human experience for the creation and inhabitation of architecture.

 CLAY

- 1 Gaston Bachelard, *Water and Dreams: An Essay on the Imagination of Matter*, (Dallas: Pegasus Foundation, 1983), page 111
- 2 Ovid, *Metamorphoses*, Book 1, lines 81-85
- 3 Genesis, chapter 2, verses 7-8, Knox translation
- 4 Gilbert Simondon, *L'individu et sa genèse physico-biologique*, trans. Taylor Adkin, (Paris: Presses Universitaires de France, 1964), accessed May 15, 2013, <http://thefunambulist.net/2012/12/08/philosophy-form-matter-gilbert-simondons-critique-of-the-hylomorphic-scheme-part-1/>
- 5 "Clay: Firing Process," Big Ceramic Store, accessed May 15, 2013, <http://www.bigceramicstore.com/information/tip31.htm>
- 6 R.F. Giese, "Cation Patterns and Information Storage" in Cairns-Smith, Ed., *Clay Minerals and the Origin of Life*, (New York: Cambridge University Press, 1986), page 41
- 7 Ibid.
- 8 "Plastic limit is the lowest moisture content, expressed as a

- percentage by weight of the oven-dry soil, at which the soil can be rolled into threads 1/8 inch in diameter without breaking into pieces. Liquid limit is the moisture content, expressed as a percentage by weight of the oven-dry soil, at which the soil will just begin to flow when jarred slightly." W. Arthur White, "Attenberg Plastic Limits of Clay Minerals," accessed May 15, 2013, http://www.minsocam.org/ammin/AM34/AM34_508.pdf
- 9 Stephen M. Hollister, "The Dirty Little Secrets of Nurbs," Pilot3d, copyright 2001, accessed May 15, 2013, <http://www.pilot3d.com/NurbSecrets.htm>
 - 10 3d Earth Workshop Blog, accessed May 15, 2013, <http://3dearthworkshopiscteiu.wordpress.com/>

FORMING

- 1 "Hanson Brick Northern Collection Residential Brick Guide," Hanson Brick, accessed May 15, 2013, http://www.hansonbrick.com/english/pdf/products/northern_collection_residential_brick_guide-english.pdf

- 2 "What To Expect With New Home Construction," Mattamy Homes, accessed May 15, 2013, <http://www.mattamyhomes.com/GTA/Service-Centre/What-To-Expect.php>
- 3 David Leatherbarrow and Mohsen Mostafavi, *Surface Architecture*, (Cambridge, Ma: MIT Press, 2002), page 1
- 4 Ibid.
- 5 Ibid., page 242
- 6 Walter Benjamin, "Paris, Capital of the Nineteenth Century (Exposé of 1935)" in *The Arcades Project*, ed. Rolf Tiedemann, (Cambridge, MA: Belknap Press, 2002), page 46
- 7 "For Benjamin, it was the destiny of the working masses to realize the non-instrumental potentiality of industry and yet the latent physiognomy of technical forms remained constrained under the rule of the bourgeoisie, just as the workers were themselves." Detlef Mertins, "Walter Benjamin and the Tectonic Unconscious," in Benjamin, Andrew, ed., *Walter Benjamin and Art*, (New York : Continuum, 2005), page 149
- 8 Walter Benjamin, "Theses on the Philosophy of History," in *Illuminations*, (New York : Harcourt, Brace & World, 1968), page 261
- 9 "We see evidence of this in the very considerable amount of effort that ever since its invention in the mid-nineteenth century has been put into 'naturalizing' this novel product, generally by making it look like either stone or wood." Adrian Forty, *Concrete and Culture*, (London: Reaktion Books Ltd., 2012), page 44
- 10 Luis Fernandez-Galiano, *Fire and Memory: On Architecture and Energy*, trans. Gina Cariño, (Cambridge, Mass.: MIT Press, 2000), page 67
- 11 The task of the historical materialist, according to Benjamin, is to seize hold of "a past charged with the time of the now [...] blasted out of the continuum of history". If this is accomplished in the "open air of history", it is a dialectic. Walter Benjamin, "Theses on the Philosophy of History," in *Illuminations*, New York : Harcourt, Brace & World, 1968, page 261
- 12 "Unlocking Buckinghamshire's Past: Brickworks," Buckinghamshire County Council, accessed February 6, 2013, <https://ubp.bucksccl.gov.uk/SingleResult.aspx?uid=TBC360>

FIRING

- 1 According to Vitruvius, who borrowed from Greek and Roman mythology, "it is the discovery of fire that gives rise to human society." Fernández-Galiano, *Fire and Memory: On Architecture and Energy*.
- 2 Ellen Baum, "Black Carbon from Brick Kilns", Clean Air Task Force, accessed May 15, 2013, http://www.catf.us/resources/presentations/files/Black_Carbon_from_Brick_Kilns.pdf
- 3 Baum, "Black Carbon from Brick Kilns," and Theo Schilderman, "Sustainable Small-Scale Brick Production: A Question of Energy," *Practical Action*, published February 2,

ENDNOTES |

- 2002, accessed May 15, 2013, <http://practicalaction.org/sustainable-small-scale-brick-production-a-question-of-energy>, among others.
- 4 "Measures of Sustainability: Embodied Energy," Canadian Architect, accessed May 15, 2013, http://www.canadianarchitect.com/asf/perspectives_sustainability/measures_of_sustainability/measures_of_sustainability_embodied.htm
- 5 Dr P S Chani, Dr Najamuddin, Dr S K Kaushik, "Comparative Analysis of Embodied Energy Rates for Walling Elements in India," *The Institution of Engineers (India) Journal*, Volume 84 (October 2003), page 48
- 6 "Measures of Sustainability: Embodied Energy"
- 7 Ibid.
- 8 "Clay: Firing Process," Big Ceramic Store, accessed May 15, 2013, <http://www.bigceramicstore.com/information/tip31.htm>
- 9 Ibid.
- 10 Hannah Arendt, *The Human Condition*, (Chicago: University of Chicago Press, 1998), page 136
- 11 Ibid.
- 12 Luis Fernández-Galiano, *Fire and Memory: On Architecture and Energy*, page 65
- 13 "Clay Brick Manufacture Technical Guide," Construction Industry Development Board South Africa, published August 8, 2007, accessed May 15, 2013, http://www.cidb.org.za/Documents/KC/Other_Publications/claybrick_manufacture_technical_guide.pdf
- 14 James W.P. Campbell, *Brick: A World History*, (London: Thames and Hudson, 2003), page 212
- 15 The Bull's Trench kiln used to have a mobile chimney that workers moved to follow the fire. This was so dangerous and energy inefficient that it is now illegal. "The Brick Industry: Kiln Types," Habla Kilns, accessed May 15, 2013, <http://www.hablakilns.com/industry.htm>
- 16 Urs Heierli, "The Most Energy Efficient Brick Kiln," Swiss Agency for Development and Cooperation, accessed May 15, 2013, <http://www.poverty.ch/asian-brick-industry/energy-efficient-kiln.html>
- 17 Schilderman, <http://practicalaction.org/sustainable-small-scale-brick-production-a-question-of-energy>
- 18 Heierli, "The Most Energy Efficient Brick Kiln."
- 19 Schilderman, <http://practicalaction.org/sustainable-small-scale-brick-production-a-question-of-energy>
- 20 Boral, Hanson, ACME, Wienerberger, and CRH control over 2/3 of the American brick market. "Wienerberger: Frequently Asked Questions," accessed June 24, 2013, <http://www.wienerberger.com/press/faq>
- 21 Ibid.
- 22 Small-Scale Brickmaking, accessed May 15, 2013, <http://collections.infocollections.org/ukedu/uk/d/Jh2385e/13.3.html>
- 23 "Compressed Earth Blocks (CEB)," United Nations Centre for Human Settlements, accessed May 15, 2013,

- http://www.unhabitat.org/downloads/docs/3629_74602_Compressed.pdf
- 24 E. A. Adam and A.R.A. Agib, "Compressed Stabilized Earth Block Manufacture in Sudan", United Nations Educational, Scientific and Cultural Organization, accessed May 15, 2013, <http://unesdoc.unesco.org/images/0012/001282/128236e.pdf>
- 25 Ibid., and <http://www.deistaf.unifi.it/upload/sub/personale/barbari/rise rvata/rossi/CompressedEarthBlocksVol1.pdf>
- 26 Hannah Arendt, *The Human Condition*, (Chicago: University of Chicago Press, 1998), page 125
- 27 Malcolm Gladwell, *The Outliers*, (London: Penguin, 2009), page 236
- 28 Schilderman, <http://practicalaction.org/sustainable-small-scale-brick-production-a-question-of-energy>
- 3 "The Flexlock Wall System," Cercorp Initiatives Inc., accessed June 22, 2013, http://www.cercorp.com/#!__flexlock
- 4 Stephen Kieran and James Timberlake, *Refabricating Architecture: How Manufacturing Methodologies are Poised to Transform Building Construction*, (New York: McGraw-Hill 2004), page 115
- 5 Bricks produced at the Hanson factory in Burlington comply with ASTM C216 standards for construction tolerances. "Specification for Face Brick," Hanson Group, published January 2009, accessed June 22, 2013, http://www.hansonbrick.com/english/pdf/techNotes/spec_for_face_brick.pdf
- 6 Cercorp Initiatives Inc., "The Flexlock Wall System"
- 7 "Porotherm Installation Brochure," Wienerberger Ltd., accessed June 22, 2013, <http://www.wienerberger.co.uk/walls/blocks/literature/download-brochure/-view-online/porotherm-installation.html?lpi=1313012152978>
- 8 Ibid.
- 9 David Leatherbarrow, *Uncommon Ground: Architecture, Technology, and Topography*, Cambridge, MA: MIT Press, 2000, page 191
- 10 Ibid., page 282-283
- 11 Reyner Banham, "Sparks from a Plastic Anvil: The Craftsman In Technology", reprinted in *The Journal of Modern Craft*, volume 1 (1) March 2008, page 140
- 12 Manuel Kretzer, in discussion with the author, ETH Zurich,

ASSEMBLY

- 1 Robert C. Mack and John P. Speweik, "Repointing Mortar Joints in Historic Masonry Buildings," U.S. National Park Service Preservation Briefs, accessed June 22, 2013, <http://www.nps.gov/tps/how-to-preserve/briefs/2-repoint-mortar-joints.htm>
- 2 "Interlocking Soil-Cement Brick Technology," Habitech Centre, accessed June 22, 2013, http://www.unicef.org/education/files/Interlocking_Earth_Bricks_technology.pdf

ENDNOTES |

May 3 2013

- 13 Volker Helm, Selen Ercan, Fabio Gramazio, Matthias Kohler, "In-Situ Robotic Construction", in *Proceedings of the 32nd ACADIA Conference 2012*, (San Francisco, 2012)
- 14 Bob Sheil, "De-fabricating Protoarchitecture", in *Prototyping Architecture: The Conference Papers*, digital publication, page 375
- 15 Fabio Gramazio and Matthias Kohler, "R-O-B Towards a Bespoke Building Process" in *Manufacturing the Bespoke: Making and Prototyping Architecture*, (Chichester: John Wiley, 2012), page 78

PERFORMANCE

- 1 Kiel Moe, "Do More with Less," *Architect Magazine*, January 2011, page 147
- 2 "Measures of Sustainability: Embodied Energy," Canadian Architect, accessed May 15, 2013, http://www.canadianarchitect.com/asf/perspectives_sustainability/measures_of_sustainability/measures_of_sustainability_embodied.htm
- 3 Kiel Moe, "Do More with Less," page 147
- 4 Eladio Dieste, "Architecture and Construction," in *Eladio Dieste: Innovation in Structural Art*, (New York: Princeton Architectural Press, 2004), page 187
- 5 John A. Ochsendorf, "Eladio Dieste as Structural Artist," in *Eladio Dieste: Innovation in Structural Art*, page 104
- 6 "Additives of the Wienerberger Group," Wienerberger Ltd., accessed June 26, 2013, <http://www.wienerberger.com/sustainability/environmental-protection-in-production/material-flows/additives>
- 7 "Porotherm U-Value Calculator," Wienerberger AG, accessed June 26, 2013, <http://www.porothermuk.co.uk/uvalue-calculator.cfm>
- 8 Frank Händle, ed., *Extrusion in Ceramics*, (Berlin: Springer, 2009), page 74
- 9 "Encounters with Aalto: An Interview with Shigeru Ban" in *Alvar Aalto in the Eyes of Shigeru Ban*, (London: Black Dog Publishing, 2004), page 84
- 10 Researchers at Harvard University have proposed combining a 6-axis robotic arm equipped with a wire-cutting tool with an industrial clay extruder. This set of equipment would be able to create mass-customized ruled-geometry ceramic units. Stefano Andreani et. al., "Flowing matter: Robotic fabrication of complex ceramic systems," Design Robotics Group, Graduate School of Design, Harvard University, accessed July 21, 2013, research.gsd.harvard.edu/drg/files/2012/08/Flowing-Matter.pdf
- 11 Jason Oliver Vollen, "Advanced Ceramic Composite Envelope Systems", *ALA Report on University Research* Volume 5, accessed June 26, 2013, www.aia.org/practicing/research/AIAB092638
- 12 "Encounters with Aalto: An Interview with Shigeru Ban," in *Alvar Aalto in the Eyes of Shigeru Ban*, page 84
- 13 "Gantenbein Vineyard Facade, Fläsch," Gramazio and

- Kohler Architects, accessed June 26, 2013,
<http://www.gramaziokohler.com/web/e/projekte/52.html>
- 14 Fabio Gramazio and Matthias Kohler, "R-O-B Towards a Bespoke Building Process" in *Manufacturing the Bespoke: Making and Prototyping Architecture*, (Chichester: John Wiley, 2012), page 84
- 15 Eladio Dieste, "Architecture and Construction," in *Eladio Dieste: Innovation in Structural Art*, page 183
- (DIS)ASSOCIATION
- 1 Anthony M. Tung, *Preserving the World's Great Cities: The Destruction and Renewal of the Historic Metropolis*, online excerpts accessed February 21, 2012,
<http://www.anthonymtung.com/excerpts.htm>.
- 2 Ibid.
- 3 David Crowley, "People's Warsaw Popular Warsaw," *Journal of Design History* 10:2 (1997), page 208
- 4 "Historic Centre of Warsaw: Description," UNESCO, accessed June 28, 2013, <http://whc.unesco.org/en/list/30/>
- 5 David Crowley, "People's Warsaw Popular Warsaw," page 205
- 6 Gregor Thum, *Uprooted: How Breslau Became Wrocław During the Century of Expulsions*, (Princeton: Princeton University Press, 2011), page 129
- 7 Ibid., page 130
- 8 David Crowley, "People's Warsaw, Popular Warsaw," page 208
- 9 Magda Gryc (Historical Museum of Warsaw) in discussion with the author, May 2012.
- 10 Ibid.
- 11 Benjamin Cope, "Report from Praga: mega-plans, micromodernisation and precarious urbanism," *The Journal of Architecture* 15:1 (2010), page 106
- 12 Ibid., page 117
- 13 "Koneser," accessed June 22, 2013,
<http://www.koneser.eu/en.html> and "Polish BBI in €100m Warsaw residential project," Property Investor Europe News, published April 23, 2012, accessed June 22, 2013,
<http://www.pie-mag.com/articles/3059/polish-bbi-in-euro-100m-warsaw-residential-project/>
- 14 Anthony M. Tung, *Preserving the World's Great Cities: The Destruction and Renewal of the Historic Metropolis*, online excerpts accessed February 21, 2012,
<http://www.anthonymtung.com/excerpts.htm>.
- 15 Adrian Wójcik, Michał Bilewicz, Maria Lewicka, "Living on the ashes: Collective representations of Polish–Jewish history among people living in the former Warsaw Ghetto area," *Cities* (2010), page 2
- 16 Katarzyna Wagner (Historical Museum of Warsaw), in conversation with the author, May 2012.
- 17 "Porotherm Core Range," Wienerberger Ltd., accessed July 21, 2013, <http://www.wienerberger.co.uk/walls/blocks/product-range/the-blocks>

 BOOKS

- Alvar Aalto Through the Eyes of Shigeru Ban.* eds. Juhani Pallasmaa and Tomoko Sato. London : Black Dog Publishing, 2007.
- Eladio Dieste : Innovation in Structural Art.* ed. Stanford Anderson. New York : Princeton Architectural Press, 2004.
- Extrusion in Ceramics.* ed. Frank Händle. Berlin: Springer, 2009.
- Manufacturing the bespoke : Making and prototyping architecture.* ed. Bob Sheil. Chichester: John Wiley, 2012.
- Clay minerals and the origin of life,* eds. Alexander Graham Cairns-Smith and H. Hartman. New York: Cambridge University Press, 1986
- Arendt, Hannah, *The human condition.* Chicago: University of Chicago Press, 1998 .
- Bachelard, Gaston, *Water and dreams : An essay on the imagination of matter.* Dallas: Pegasus Foundation, 1983
- Benjamin, Walter, *The arcades project.* ed. Rolf Tiedemann. Cambridge, Mass.: Belknap Press, 1999 .
- . *Illuminations.* New York : Schocken Books, 1968.
- Campbell, James W. P. *Brick : A world history.* ed. Will Pryce. New York: Thames & Hudson, 2003.
- Ciborowski, Adolf. *Warsaw, a city destroyed and rebuilt.* Warsaw: Polonia Pub. House, 1964.
- Fernández-Galiano, Luis. *Fire and memory : On architecture and energy.* Cambridge, Mass. : MIT Press, 2000.
- Forty, Adrian. *Concrete and Culture.* London: Reaktion Books Ltd., 2012.
- Gladwell, Malcolm, *Outliers : The story of success.* London: Penguin, 2009.
- Helm, Volker, Selen Ercan, Fabio Gramazio, Matthias Kohler. “In-Situ Robotic Construction.” In *Proceedings of the 32nd ACADIA Conference 2012.* San Francisco, 2012; pages 169-176.
- Kieran, Stephen, and James Timberlake. *Refabricating architecture : How manufacturing methodologies are poised to transform building construction.* London: McGraw-Hill,

2004.

Leatherbarrow, David. *Uncommon ground : Architecture, technology, and topography*. Cambridge, Mass.: MIT Press, 2000.

Mertins, Detlef. "Walter Benjamin and the Tectonic Unconscious." In *Walter Benjamin and Art*, ed. Andrew Benjamin. New York : Continuum, 2005.

Leatherbarrow, David, and Mohsen Mostafavi. *On weathering : The life of buildings in time*, ed. David Leatherbarrow. Cambridge, Mass.: MIT Press, 1993.

Ovid. *Metamorphoses*. trans. Rolf Humphries. Bloomington: Indiana University Press, 1983.

Pye, David W. *The nature and art of workmanship*. New York: Van Nostrand Reinhold, 1971.

Thum, Gregor. *Uprooted : How Breslau became Wrocław during the century of expulsions*. Princeton N.J.: Princeton University Press, 2011.

Tung, Anthony M. *Preserving the world's great cities : The destruction and renewal of the historic metropolis*. New York: Three Rivers Press, 2001

ARTICLES

Banham, Reyner. "Sparks from a Plastic Anvil: The Craftsman In Technology." Reprinted in *The Journal of Modern Craft* 1:1 (March 2008); pages 137-146

Chani, Dr. P.S., Dr Najamuddin, and Dr S K Kaushik. "Comparative Analysis of Embodied Energy Rates for Walling Elements in India." *The Institution of Engineers*

(India) *Journal* 84 (October 2003); pages 47-50.

Crowley, David. "People's Warsaw Popular Warsaw." *Journal of Design History* 10:2 (1997); pages 203-223

Cope, Benjamin. "Report from Praga: mega-plans, micromodernisation and precarious urbanism." *The Journal of Architecture* 15:1 (2010); pages 105-120

Moe, Kiel. "Do More with Less." *Architect Magazine* January 2011; pages 147-148.

Vollen, Jason Oliver. "Advanced Ceramic Composite Envelope Systems." *ALA Report on University Research* 5 (2009). Accessed June 26, 2013.

www.aiaa.org/practicing/research/AIAB092638

Wójcik, Adrian, Michał Bilewicz, Maria Lewicka. "Living on the ashes: Collective representations of Polish-Jewish history among people living in the former Warsaw Ghetto area." *Cities* (2010), pages 1-8

WEB SOURCES

3d Earth Workshop Blog. Accessed May 15, 2013.

<http://3dearthworkshopisteiul.wordpress.com/>

Adam, E.A., and A.R.A. Agib. "Compressed Stabilized Earth Block Manufacture in Sudan." United Nations Educational, Scientific and Cultural Organization. Accessed May 15, 2013. <http://unesdoc.unesco.org/images/0012/001282/128236e.pdf>

Andreani, Stefan, Jose Luis Garcia del Castillo, Aurggho Jyoti, Nathan King, and Martin Bechthold. "Flowing matter:

BIBLIOGRAPHY |

- Robotic fabrication of complex ceramic systems.” Design Robotics Group, Graduate School of Design, Harvard University. Accessed July 21, 2013, research.gsd.harvard.edu/drg/files/2012/08/Flowing-Matter.pdf
- Baum, Ellen. "Black Carbon from Brick Kilns." Clean Air Task Force. Accessed May 15, 2013. http://www.catf.us/resources/presentations/files/Black_Carbon_from_Brick_Kilns.pdf
- Big Ceramic Store. "Clay: Firing Process." accessed May 15, 2013, <http://www.bigceramicstore.com/information/tip31.htm>
- Buckinghamshire County Council. "Unlocking Buckinghamshire's Past: Brickworks." Accessed February 6, 2013. <https://ubp.buckscc.gov.uk/SingleResult.aspx?uid=TBC360>
- Canadian Architect. "Measures of Sustainability: Embodied Energy." Accessed May 15, 2013. http://www.canadianarchitect.com/asf/perspectives_sustainability/measures_of_sustainability/measures_of_sustainability_embodied.htm
- Cercorp Initiatives Inc. "The Flexlock Wall System." Accessed June 22, 2013. http://www.cercorp.com/#!/__flexlock
- Construction Industry Development Board South Africa. "Clay Brick Manufacture Technical Guide." Published August 8, 2007. Accessed May 15, 2013. http://www.cidb.org.za/Documents/KC/Other_Publications/claybrick_manufacture_technical_guide.pdf
- Gramazio and Kohler Architects. "Gantenbein Vineyard Facade, Fläsch." Accessed June 26, 2013. <http://www.gramaziokohler.com/web/e/projekte/52.html>
- Habla Kilns. "The Brick Industry: Kiln Types." Accessed May 15, 2013. <http://www.hablakilns.com/industry.htm>
- Habitech Centre. "Interlocking Soil-Cement Brick Technology." Accessed June 22, 2013. http://www.unicef.org/education/files/Interlocking_Earth_Bricks_technology.pdf
- Hanson Group. "Hanson Brick Northern Collection Residential Brick Guide." Accessed May 15, 2013. http://www.hansonbrick.com/english/pdf/products/northern_collection_residential_brick_guide-english.pdf
- . "Specification for Face Brick." Published January 2009. Accessed June 22, 2013. http://www.hansonbrick.com/english/pdf/techNotes/spec_for_face_brick.pdf
- Heierli, Urs. "The Most Energy Efficient Brick Kiln." Swiss Agency for Development and Cooperation. Accessed May 15, 2013. <http://www.poverty.ch/asian-brick-industry/energy-efficient-kiln.html>
- Hollister, Steven M., "The Dirty Little Secrets of Nurbs," Pilot3d, copyright 2001, accessed May 15, 2013, <http://www.pilot3d.com/NurbSecrets.htm>
- Mack, Robert C., and John P. Speweik. "Repointing Mortar Joints in Historic Masonry Buildings." U.S. National Park Service Preservation Briefs. Accessed June 22, 2013.

- <http://www.nps.gov/tps/how-to-preserve/briefs/2-repoint-mortar-joints.htm>
- Mattamy Homes. "What To Expect With New Home Construction." Accessed May 15, 2013. <http://www.mattamyhomes.com/GTA/Service-Centre/What-To-Expect.php>
- Novabrik. "Novabrik Self-Ventilating Mortarless Brick Siding." Accessed June 29, 2013. http://www.novabrik.com/html/en_stage/accueil/index.php3?flash=2
- Schilderman, Theo. "Sustainable Small-Scale Brick Production: A Question of Energy." Practical Action. Published February 2, 2002. Accessed May 15, 2013. <http://practicalaction.org/sustainable-small-scale-brick-production-a-question-of-energy>.
- Sheil, Bob. "De-fabricating Protoarchitecture." In *Prototyping Architecture: The Conference Papers*. Digital publication. <http://www.buildingcentre.co.uk/Prototyping%20Architecture.pdf>
- Simondon, Gilbert. *L'individu et sa genèse physico-biologique*, trans. Taylor Adkin. Paris: Presses Universitaires de France, 1964. Accessed May 15, 2013. <http://thefunambulist.net/2012/12/08/philosophy-form-matter-gilbert-simondons-critique-of-the-hylomorphic-scheme-part-1/>
- "Small-Scale Brickmaking." Accessed May 15, 2013. <http://collections.infocollections.org/ukedu/uk/d/Jh2385e/13.3.html>
- UNESCO. "Historic Centre of Warsaw: Description." Accessed June 28, 2013. <http://whc.unesco.org/en/list/30/>
- United Nations Centre for Human Settlements. "Compressed Earth Blocks (CEB)." Accessed May 15, 2013. http://www.unhabitat.org/downloads/docs/3629_74602_Compressed.pdf
- Weinerberger Ltd. "Wienerberger: Frequently Asked Questions." Accessed June 24, 2013. <http://www.wienerberger.com/press/faq>
- . "Porotherm Installation Brochure." Accessed June 22, 2013. <http://www.wienerberger.co.uk/walls/blocks/literature/download-brochure/-view-online/porotherm-installation.html?lpi=1313012152978>
- . "Additives of the Wienerberger Group." Accessed June 26, 2013. <http://www.wienerberger.com/sustainability/environmental-protection-in-production/material-flows/additives>
- . "Porotherm U-Value Calculator." Accessed June 26, 2013. <http://www.porothermuk.co.uk/uvalue-calculator.cfm>
- . "Porotherm Core Range." Accessed July 21, 2013. <http://www.wienerberger.co.uk/walls/blocks/product-range/the-blocks>
- White, Arthur W. "Attenberg Plastic Limits of Clay Minerals." Mineralogical Society of America. Accessed May 15, 2013. http://www.minsocam.org/ammin/AM34/AM34_508.pdf

APPENDIX | “Building the Terracott”

This appendix is a documentary video of the construction process of the Terracott.
The name of this file is Building_the_Terracott.mpg

If you accessed this thesis from a source other than the University of Waterloo, you may not have access to this file. You may access it by searching for this thesis at <http://uwspace.uwaterloo.ca> .