

Allocating Power Quality Monitors in Electrical Distribution Systems to Measure and Detect Harmonics Pollution

by

Yassir Alhazmi

A thesis
presented to the University of Waterloo
in fulfillment of the
thesis requirement for the degree of
Master of Applied Science
in
Electrical and Computer Engineering

Waterloo, Ontario, Canada, 2010

© Yassir Alhazmi 2010

AUTHOR'S DECLARATION

I hereby declare that I am the sole author of this thesis. This is a true copy of the thesis, including any required final revisions, as accepted by my examiners.

I understand that my thesis may be made electronically available to the public.

Abstract

The growth of non-linear devices has increased the harmonics pollution in distribution systems. Under industrial competition, the concern over power quality, especially harmonic distortion, has increased due to the new generation of load equipment. This equipment has been fully automated electronically, so it is very sensitive to any power quality disturbances. Electrical power organizations have set standards to limit the harmonics pollution in the distribution systems; however, the enforcement of the standards has to be disciplinal, by applying a penalty fee for any customer or utility that exceeds the standard limits. In order to apply the penalty fee properly, precise detection of harmonics pollution sources must be considered. The bus voltages and the line currents in the entire system have to be known in order to obtain accurate identification, which can be achieved by monitoring the distribution system. The large number of sensors needed to monitor the distribution system increases the cost of the monitoring system; therefore, the sensors have to be installed in an optimum way that decreases their quantity and their construction fixed costs. This thesis offers a new optimization approach for allocating the monitors in the distribution system. The Vertex-Colouring approach reduces the monitoring system cost by placing the harmonics pollution monitors in minimum cost locations where they can observe all the buses and branches of the distribution system. The number of monitors is affected by the percentage of nonlinear loads in the distribution network; thus, investigations on lightly polluted systems, medium polluted systems, and heavily polluted systems have been presented. The relation between the harmonics pollution level from one side, and the nonlinear load types, power ratings, and voltage levels from the other side has been highlighted as important observations of the polluted systems investigation. The Total Harmonic Powers (THP) method has been used to identify the harmonics pollution sources. In addition to its simplicity, The THP method is efficient, and requires the network voltage and current values which can be provided by the proposed monitoring system. The ability to apply the THP method on any distribution system has been scrutinized in order to confirm its validity for distribution systems.

Acknowledgements

First and foremost, I would like to thank and praise *Allah* almighty for enlightening my way and directing me through each and every success that I have or may reach.

I would like to thank the *Saudi Ministry of Higher Education* for the financial support of this work. I'm also indebted to *the Saudi Cultural Bureau* for their continued assistance through the course of my study at the University of Waterloo.

I would like to express my sincere gratitude to my supervisor Professor *Magdy Salama* for his endless encouragement, support and invaluable guidance throughout the duration of this research. His constant support was the secret of achieving all this work

I would also like to gratefully recognize the contribution of Professor Tarek Abdelgalil for his valuable comments in my work. I feel very fortunate to have worked with him.

My thanks also go to the members of Electrical and Computer Engineering department, especially Wendy Boles and Karen Schooley for their endless support and help.

To my friends, I would like to express my deep appreciations for their advice, comments and continuous encouragement. I am very fortunate to have so many exceptional and genuine people in my life

To my *parents*, I would like to express my deepest gratitude for their daily prayers, encouragement and moral support; May Allah reward them in this world and in the hereafter. My grateful thanks also go to all my *brothers and sisters* who have been the greatest supporters in my life.

My special thanks go to my *parents in law* for their prayers and support. They have given me the most precious gift in the world, my soul mate *Ghaida*; she is my inspiration, lover and whole life. Her endless understanding, support, patience and care are the key for accomplishing this work. She has always been available to uplift me when I felt down and to congratulate me when I achieved. I am by all means indebted to her.

Dedication

To

My parents and the rest of my family.

My lovely wife and my expected baby.

Table of Contents

Author's Declaration.....	ii
Abstract.....	iii
Acknowledgements.....	iv
Dedication.....	v
Table of Contents.....	vi
List of Figures.....	ix
List of Tables.....	xi
Chapter 1 Introduction.....	1
1.1 Background.....	1
1.2 Motivation.....	2
1.3 Methodology.....	3
1.4 Thesis layouts.....	4
Chapter 2 Power Quality Terms and Definitions.....	5
2.1 Definition of Power Quality.....	5
2.2 Power Quality Disturbances Classification.....	7
2.2.1 Transients.....	8
2.2.2 Short-Duration Variations.....	9
2.2.3 Long-Duration Variations.....	9
2.2.4 Voltage Imbalance.....	10
2.2.5 Waveform Distortion.....	10
2.2.6 Voltage Fluctuations (Flickers).....	13
2.2.7 Power Frequency Variations.....	13
2.3 Power Quality Monitoring.....	15
2.3.1 Detection Process.....	16
2.3.2 Signal Analysis.....	16
2.3.3 Disturbances Characterization.....	17
2.4 Power Quality Standards.....	18
Chapter 3 Harmonics Pollution.....	25
3.1 Harmonics Distortion.....	26
3.2 Harmonics Pollution Indices.....	28
3.2.1 Total Harmonics Distortion (THD).....	28

3.2.2 Total Demand Distortion (TDD)	28
3.3 Harmonics Current Sources.....	29
3.3.1 Residential and Commercial Loads.....	29
3.3.2 Industrial Loads.....	30
3.3.3 Control Devices.....	30
3.4 Harmonics Pollution Impact Evaluation.....	31
3.4.1 Capacitors Bank.....	31
3.4.2 Transformers.....	32
3.4.3 Motors	32
3.5 Interharmonics.....	33
Chapter 4 Monitoring Harmonics Pollution.....	34
4.1 Introduction	34
4.2 Harmonics Pollution Monitors	36
4.2.1 Transducers.....	37
4.2.2 DAQ	38
4.2.3 Analysis Tool (PC).....	38
4.3 Optimum Allocation of Harmonics Pollution Monitors.....	39
4.3.1 Graph – Coloring Optimization Technique	40
4.3.2 Problem Description.....	41
4.3.3 Mathematical Formulation	42
4.3.4 Observability Constraints	44
4.4 Applications.....	48
4.4.1 Four-Bus System	48
4.4.2 Four-bus System with Loads and Generators.....	49
4.4.3 IEEE 30-Bus.....	50
4.5 Description of IEEE Std 399-1997 System.....	51
4.6 Harmonics Monitors Allocation for IEEE Std 399-1997	56
4.7 Chapter Assessment	58
Chapter 5 Harmonics Pollution Sources Identification	60
5.1 Introduction	60
5.2 Harmonics Source Models	61
5.2.1 Non-linear Magnetic device	62

5.2.2 Non linear switching Devices	62
5.3 Investigation of Polluted Distribution System	68
5.3.1 Light Polluted System.....	69
5.3.2 Medium Polluted System	73
5.3.3 Heavy Polluted System	76
5.3.4 Discussion of polluted distribution systems.....	80
5.4 Detecting the harmonics pollution sources	81
5.4.1 Total Harmonic Power Method.....	82
5.4.2 Applications of THP method	84
5.5 Chapter Assessment	88
Chapter 6 Conclusions and Future Research	90
6.1 Conclusions.....	91
6.2 Future Research	93
Bibliography	94

List of Figures

Figure 2.1: Typical PQ disturbances waveforms	14
Figure 2.2: The ITIC curve	23
Figure 3.1: Fourier series representation of a distorted waveform.....	26
Figure 3.2: Simple network with non linear load connected to sinusoidal power source.....	27
Figure 4.1: The equivalent representation of the distribution system seen by the measuring point....	35
Figure 4.2: The basic configuration of harmonics pollution monitors [15].....	37
Figure 4.3: The interacting between two loads sharing the same PCC.....	40
Figure 4.4: A typical Example of 4 – bus system.....	42
Figure 4.5: A part of the distribution system consists of transmission line between two buses.....	44
Figure 4.6: 4 buses are connected by lines as a part of the distribution system.....	44
Figure 4.7: The flowchart of the VC method that is applied for monitors’ allocation	47
Figure 4.8: The allocation of harmonics monitor using the Vertex – Coloring method.....	48
Figure 4.9: The allocation of harmonics monitors using the VC method on Case2.....	49
Figure 4.10: IEEE 30-bus system with the location of the PQIN	50
Figure 4.11: Single Line diagram of IEEE Std 399-1997 typical power system [19].....	52
Figure 4.12: Harmonics Monitors Allocation of IEEE Std 399-1997 using VC method Case1.....	56
Figure 4.13: Harmonics Monitors Allocation of IEEE Std 399-1997 using VC method Case2.....	57
Figure 5.1: Typical current waveform and spectrum of Fluorescent lamp.....	63
Figure 5.2: Typical current waveform and spectrum of Transformer Iron Core.....	64
Figure 5.3: Typical current waveform and spectrum of ASD.....	65
Figure 5.4: Typical current waveform and spectrum of IEEE 6 Pulse converter.....	66
Figure 5.5: Typical current waveform and spectrum of IEEE 12 Pulse converter.....	66
Figure 5.6: Typical current waveform and spectrum of 12 Pulse VFD.....	67
Figure 5.7: Typical current waveform and spectrum of 18 Pulse VFD.....	67
Figure 5.8: IEEE Std. 399 – 1997 system.....	69
Figure 5.9: The harmonics spectrum of distribution harmonics – producing loads in light polluted system.....	70
Figure 5.10: The harmonics spectrum of concentrated harmonics – producing load Case 1 in light polluted system.....	72
Figure 5.11: Comparison between Case 1 and Case 2 in harmonics spectrum of concentrated harmonics – producing load of light polluted system.....	72

Figure 5.12: The harmonics spectrum of distribution harmonics – producing loads in medium polluted system.....	74
Figure 5.13: The harmonics spectrum of concentrated harmonics – producing load in medium polluted system.....	75
Figure 5.14: Comparison between Case 1 and Case 2 in harmonics spectrum of concentrated harmonics – producing load of medium polluted system.....	76
Figure 5.15: The harmonics spectrum of distribution harmonics – producing loads in heavy polluted system.....	77
Figure 5.16: The harmonics spectrum of concentrated harmonics – producing loads in heavy polluted system.....	78
Figure 5.17: Comparison between Case 1 and Case 2 in harmonics spectrum of concentrated harmonics – producing loads of heavy polluted system.....	79
Figure 5.18: Simple network with nonlinear device connected to a sinusoidal supply.....	83
Figure 5.19: Simple network with nonlinear device connected to Bus3.....	85
Figure 5.20: The 10 – Bus industrial system with two nonlinear loads connected to Bus5 and Bus9.....	86

List of Tables

Table 2-1: Characteristics of Impulsive Transients and typical causes.....	8
Table 2-2: Characteristics of Oscillatory Transients and typical causes.....	9
Table 2-3: Characteristics of Short-Duration Variations and typical causes.....	10
Table 2-4: Characteristics of Long-Duration Variations and typical causes.....	11
Table 2-5: Characteristics of Waveform Distortion and typical causes.....	13
Table 2-6: Characteristics of Voltage Imbalance, Voltage Fluctuations, and Power Frequency Variations.....	14
Table 2-7: Comparison of IEEE and IEC Power Quality Standards according to EPRI.....	20
Table 2-8: Voltage harmonic distortion limits from IEEE Std. 519-1995.....	21
Table 2-9: Current Distortion Limits for General Distribution Systems.....	21
Table 2-10: Harmonic Current emission limits for different loads equipments from IEC 1000-3-2 Std. 1995.....	22
Table 3-1: Current measurements on a 150HP, 6 – pulse VFD with no harmonics treatments.....	30
Table 4-1: Summary of IEEE Std 399-1997 Buses.....	53
Table 4-2: Summary of IEEE Std 399-1997 Transformers and Transmission Lines Data.....	54
Table 4-3: Summary of IEEE Std 399-1997 Generators and Cables Data	54
Table 4-4: Matrix components ordering in relevance to IEEE Std 399-1997.....	55
Table 5-1: Load composition in typical distribution network.....	68
Table 5-2: Distribution of harmonic – producing loads in the light polluted system.....	70
Table 5-3: A concentrated harmonic – producing load in the light polluted system.....	71
Table 5-4: Distribution of harmonic – producing loads in the medium polluted system.....	73
Table 5-5: Concentrated harmonic – producing load in the medium polluted system.....	75
Table 5-6: Distribution of harmonic – producing loads in the heavy polluted system.....	77
Table 5-7: Concentrated harmonic – producing load in the heavy polluted system.....	78
Table 5-8: Harmonic powers for simple 3 – Bus network with a single nonlinear device.....	85
Table 5-9: The bus loading for the industrial 10 – Bus system.....	86
Table 5-10: Harmonic powers of industrial 10-Bus system with two nonlinear loads.....	87

Chapter 1

Introduction

1.1 Background

In recent years, the traditional power systems' structures have been changed, and the electrical system can no longer be handled as a single entity. The conventional way of transporting electric power via transmission networks, unidirectional from generators to end users, is not adequate for the deregulated systems, so the transmission networks have to be able to support transferring energy between customers and companies [1]. The customers have options to buy the electricity from various providers, and the energy price, reliability, and quality play the main roles in the electricity market. As a result, the customers will purchase the cheapest energy that meets their needs within acceptable reliability and quality ranges [2, 3].

Under industrial competition, the concern over power quality has increased due to the new generation of load equipment. This equipment has been fully automated electronically, so it is very sensitive to any power quality disturbances [1]. Indeed, power quality disturbances may cause malfunctions in the equipment, which leads to higher production costs due to decreased production efficiency. Moreover, the electronic converters in these loads produce harmonic currents that increase current distortion. Eventually, the impact of electronic converters on power quality will be increased proportional to the converters' lifetime; therefore, maintaining power quality levels above specific baselines will be an essential requirement in future decades [3].

Customers connected to the electrical network are no longer classified only as consumers, since they can also generate and sell power via the deregulated system. Recently, the number of installed distributed generators (DGs) has risen, and connecting a new DG to the network has to meet power quality conditions that guarantee the security of the system during any power quality disturbances, especially voltage dips [1]. DGs create additional power quality disturbances, such as waveform distortion, voltage fluctuation, and flicker. In addition, the new transmission technologies, combined with electronic converters, FACTS,

and HVDCs, produce harmonic currents in the high-frequency order which cause current quality distortion [4].

The restructuring of power systems raises the concerns over power quality problems resulting from harmonics distortion. Electrical power organizations have proposed some standards in order to protect their electrical power systems from the consequences of harmonics pollution. When a customer or utility produces harmonics pollution above the limits, the cost of the harmonics pollution consequences should be paid by the responsible party; the customer or the utility. Due to the highly complex interconnected networks in the distribution systems, identifying the sources that cause harmonics pollution is a hard task to achieve.

1.2 Motivation

It is agreed that harmonics pollution is increasing in power systems, causing power losses, sensitive equipment malfunctions, and consequent additional costs. Although the concern over the problem is noticeable, the solutions are not simple. The standards already define harmonics injection limits, but how utilities can enforce all customers to follow these standards is problematic. Hence, an incentive-based regulation has been proposed, to charge the harmonics producers a penalty fee related to their harmonics pollution levels when limits are exceeded [5]. The incentive regulation is agreed by many as a solution to limit harmonics pollution in a distribution system; however, the incentive scheme faces two technical problems: identifying precisely the source of harmonics pollution in the distribution system, and isolating the effect of system impedance variation [5]. The main idea behind the incentive-based schemes is to penalize facilities that cause harmonic pollution. Of course, such schemes must be based on the determination of harmonic contributions from different sources.

Finding a precise and cost-effective system for monitoring harmonics pollution in different distribution systems is one of the objectives of this thesis. The monitoring system has to be applicable for different types of distribution systems. It should have the ability of measuring harmonics pollution levels and detecting harmonics distortion sources. Providing

accurate identification of harmonics sources and isolating the effect of distribution systems' impedance variations has to be handled by the monitoring system.

1.3 Methodology

The origins of harmonics pollution can exist anywhere in the power system: on the generation side, load side, and even in the transmission network itself under modern electrical power system structures; as a result, identifying the harmonics source location will be a hard challenge facing the researchers. In order to detect and then measure the harmonics pollution, the first step is having a smart harmonics monitoring system that can detect and localize the harmonics pollution sources automatically; this harmonics monitoring system has to satisfy some requirements to be applicable:

- Accurate measuring system with low cost
- Adequate harmonics pollution detection technique able to detect different types of harmonics distortion in various distribution systems
- Precise harmonics sources localization technique that can be able to identify the origin of the harmonics distortion
- Fully automated and easily developed

Various methods for determining the customer's and utility's shares in harmonics pollution have already been highlighted in the literature [6–12]. Simple and practical approaches are based on methods where the detection of harmonic sources is based on measurements at the point of common coupling (PCC) between a customer and a utility. Unfortunately, the identification of sources polluting the system cannot generally be achieved by means of measurements in a single metering section of the electrical network [13]. The dynamic nature of the distribution systems has to be addressed in the measuring methods. The multiple-point measurement method [14] is an adequate solution, but it suffers from high implementation costs [4, 15]. However, the cost of the multiple-point measurement method can be reduced by applying optimization techniques in order to keep the cost within an acceptable range.

1.4 Thesis layouts

This thesis is organized into six chapters. Chapter 1 is introductory, and it summarizes the background, the motivation, the methodology, and the organization of the thesis. Chapter 2 is a review of power quality definitions, power quality disturbance classifications, power quality monitoring, and the proposed power quality standards. Chapter 3 presents an extensive survey on harmonics pollution, covering its sources and effects. Monitoring the harmonics pollution using distributed monitors is shown in Chapter 4. A novel optimization approach for allocating the harmonics pollution monitors in distribution systems is demonstrated and the applications of the proposed method are discussed. Chapter 5 presents harmonics sources modeling, investigation of different types of polluted distribution systems, and harmonics pollution sources detection methods. Finally, Chapter 6 offers the main conclusions of this thesis and suggests subjects for future research.

Chapter 2

Power Quality Terms and Definitions

2.1 Definition of Power Quality

Many sources in the literature have addressed the importance of power quality; however, there is no single agreed definition for the term “*power quality*”, and various sources have different and sometimes inconsistent definitions for it. In addition, “*power quality*” is sometimes used loosely to express different meanings: “*supply reliability*”, “*service quality*”, “*voltage quality*”, and “*current quality*” [16]. The multiple meanings of power quality are the result of defining power quality from different perspectives. Power quality, in generation, relates to the ability to generate electric power at a specific frequency, 50 or 60 Hz, with very little variation; while power quality in transmission can be referred to as the *voltage quality*. At the distribution level, power quality can be a combination of *voltage quality* and *current quality*. From the marketing point of view, electricity is a product and the power quality is the index of the product quality [15].

The Institute of Electrical and Electronics Engineers (IEEE) defines power quality in the IEEE standard 1159-1995 as: “*power quality is the concept of powering and grounding sensitive equipment in a manner that is suitable to the operation of that equipment*” [1]. This definition limits the term power quality to only sensitive equipment, and this definition narrows down the impact of harmonic currents to consider it as affecting only that equipment [1]. The International Electrotechnical Commission (IEC) states in IEC 61000-4-30 [17] that “*Characteristics of the electricity at a given point on an electrical system, evaluated against a set of reference technical parameters.*” The definition evaluates power quality as depending on its measurement and quantity from a power system point of view.

Heydt, in *Electric Power Quality* (1994), defines power quality as “*power quality is the measure, analysis, and improvement of bus voltage, usually a load bus voltage, to maintain*

that voltage to be a sinusoid at rated voltage and frequency.” It is clear that Heydt defined power quality from the utility’s point of view; the definition confines the meaning of power quality only to voltage quality. Indeed, before deregulation took place, the electrical system structure was vertical, and the electrical utility was the only entity taking care of power quality problems. The electrical utility can only control the voltage and the frequency; however, it has no control over the current that particular loads might draw. Thus, voltage quality problems were the focus at that time, or in other words, power quality problems were handled as voltage quality problems.

The increasing of nonlinear and sensitive loads in the distribution system causes noticeable current deviations that lead to power quality disturbances; therefore, power quality problems are no longer considered as only voltage quality problems. Dugan et al. define power quality problems in [18] as *“any power problem manifested in voltage, current, or frequency deviations that results in failure or misoperation of customer equipment.”* This definition covers the possible reasons that can cause power quality disturbances; however, power quality disturbances can result from more than one source. Because of the close relationship between voltage and current in any practical power system, any deviation in the current will affect the voltage and vice versa. Bollen defines power quality in his book *Understanding Power Quality Problems* [19] as *“power quality is the combination of voltage quality and current quality. Thus power quality is concerned with deviations of voltage and/or current from the ideal.”* So, any deviation of voltage or current from the ideal is a power quality disturbance.

It is hard to distinguish between voltage disturbances and current disturbances due to the close relationship between the two, and there is no common reference point that the disturbance can be seen from. For instance, starting a large induction motor leads to an overcurrent; this is a current disturbance from the network perspective. However, the neighbouring loads can suffer from a voltage dip, which is considered a voltage disturbance from another perspective. This action, starting an induction motor, leads to a disturbance that can be looked at from different perspectives: as a voltage disturbance from one point and a current disturbance from the other. The distinguishing complexity makes using the term

“*power quality disturbance*” more preferable in general; however, the underlying cause of a disturbance is still either a voltage deviation or a current deviation [19].

Much recent research has focused on classifying power quality disturbances according to the underlying causes [2, 20], but it is still a difficult classification. However, the typical power quality disturbance classification is usually based on voltage magnitude and frequency variation for different time durations. The typical classification has been specified by many sources, such as IEEE and IEC. The classification of power quality disturbances can help in understanding power quality phenomena, and it is considered the base for monitoring and mitigating power quality problems.

2.2 Power Quality Disturbances Classification

In order to be able to classify different types of power quality disturbances, the characteristics of each type must be known. In general, power quality disturbances are classified into two types: steady state and non-steady state. This classification is done in terms of the frequency components which appear in the voltage signals during the disturbance, the duration of the disturbance, and the typical voltage magnitude. These disturbances are mainly caused by [17]:

- External factors to the power system: for example, lightning strikes cause impulsive transients of large magnitude.
- Switching actions in the system: a typical example is capacitor switching, which causes oscillatory transients.
- Faults which can be caused, for example, by lightning (on overhead lines) or insulation failure (in cables). Voltage dips and interruptions are disturbances related to faults.
- Loads which use power electronics and introduce harmonics to the network.

Different power quality disturbances classified as to *IEEE Std. 1159, 1995* [1] will be discussed below:

2.1.1. Transients

Pertaining to or designating a phenomenon or a quantity that varies between two consecutive steady states during a time interval that is short compared to the time scale of interest. A transient can be a unidirectional impulse of either polarity or a damped oscillatory wave with the first peak occurring in either polarity [1]. Transients refer to variations in the voltage waveform, which results in over-voltage conditions for a fraction of a cycle of the fundamental frequency. Transients are classified as impulsive or oscillatory.

2.2.1.1. Impulsive Transients:

According to [1], an impulsive transient is a sudden non-power frequency change in the steady-state condition of voltage or current that is unidirectional in polarity (either positive or negative). The general characteristics of the impulsive transients are shown in Table 2.1.

2.2.1.2. Oscillatory Transients

This is a sudden change in the steady-state condition of the voltage or current. It includes both positive and negative polarity values. It is described by its spectral content, duration, and magnitude. Using the spectral content, the oscillatory transient is classified into three subclasses:

- High-frequency oscillatory transient
- Medium-frequency oscillatory transient
- Low-frequency oscillatory transient

The general characteristics of different oscillatory transients are summarized in Table 2.2

Table 2.1: Characteristics of Impulsive Transients and typical causes

Impulsive Transients	Typical Spectral Content	Typical Duration	Typical Voltage Magnitude
Nanosecond	5 ns rise	< 50 ns	-----
Microsecond	1 μ s rise	50 ns – 1 ms	-----
Millisecond	0.1 ms rise	> 1 ms	-----
<i>Typical Causes</i>	<i>Lightning, Electrostatic discharge, Load switching</i>		

Table 2.2: Characteristics of Oscillatory Transients and typical causes

Oscillatory Transients	Typical Spectral Content	Typical Duration	Typical Voltage Magnitude
Low frequency	< 5 kHz	3 – 50 ms	-----
Medium frequency	5.500 kHz	20 μ s	-----
High frequency	0.5 – 5 MHz	5 μ s	-----
<i>Typical Causes</i>	<i>Line/cable switching, Capacitor switching, Load switching</i>		

2.2.2 Short-Duration Variations

These are variations of the RMS (root mean square) value of the voltage from nominal voltage for a time greater than 0.5 cycles of the power frequency but less than or equal to 1 minute. Usually further described using a modifier indicating the magnitude of a voltage variation (e.g., *sag*, *swell*, or *interruption*), and possibly a modifier indicating the duration of the variation (e.g., *instantaneous*, *momentary*, or *temporary*) [1]. Table 2.3 shows the different characteristics of short-duration voltage variations.

2.2.2.1 Voltage Sag (Dip)

This is a decrease to between 0.1 and 0.9 pu in RMS voltage or current at the power frequency for durations of 0.5 cycle to 1 minute.

2.2.2.2 Voltage Swell

This is an increase in RMS voltage or current at the power frequency for durations from 0.5 cycles to 1 minute. Typical values are 1.1 – 1.8 pu.

2.2.2.3 Voltage Interruption

This is complete loss of voltage (< 0.1 pu) on one or more phase conductors for a time period between 0.5 cycles and 3 seconds (*momentary*), and between 3 seconds and 1 minute (*temporary*).

2.2.3 Long-Duration Variations

This is a variation of the RMS value of the voltage from nominal voltage for a time greater than 1 minute, usually further described using a modifier indicating the magnitude of a voltage variation (e.g., *under-voltage*, *over-voltage*, or *voltage interruption*). It is caused by load variations on the system or system switching operations.

2.2.3.1 Over-voltage

This is a measured voltage having a value greater than the *nominal voltage* for a period of time greater than 1 minute. Typical values are 1.1 – 1.2 pu.

2.2.3.2 Under-voltage

This is a measured voltage having a value less than the *nominal voltage* for a period of time greater than 1 minute. Typical values are 0.8 – 0.9 pu.

2.2.3.3 Sustained Interruption

Sustained interruption is a zero supply voltage for duration longer than one minute. The general characteristics of over-voltage, under-voltage, and sustained interruptions are summarized in Table 2.4 as indicated in [1].

Table 2.3: Characteristics of Short-Duration Variations and typical causes

Short-Duration Variations	Typical Spectral Content	Typical Duration	Typical Voltage Magnitude
A. Instantaneous			
Sag	-----	0.5 – 30 cycles	0.1 – 0.9 pu
Swell	-----	0.5 – 30 cycles	1.1 – 1.8 pu
B. Momentary			
Interruption	-----	0.5 – 3 sec.	< 0.1 pu
Sag	-----	30 cycles – 3 sec.	0.1 – 0.9 pu
Swell	-----	30 cycles – 3 sec.	1.1 – 1.4 pu
C. Temporary			
Interruption	-----	3 sec. – 1 min.	< 0.1 pu
Sag	-----	3 sec. – 1 min.	0.1 – 0.9 pu
Swell	-----	3 sec. – 1 min.	1.1 – 1.2 pu
Typical Sag causes	Remote system faults, large loads, and non-linear loads		
Typical Swell causes	Remote system faults, large loads, and non-linear loads		
Typical Interruption causes	System protection and maintenance		

Table 2.4: Characteristics of Long-Duration Variations and typical causes

Long-Duration Variations	Typical Spectral Content	Typical Duration	Typical Voltage Magnitude
Over-voltage	-----	> 1 min.	1.1 – 1.2 pu
Under-voltage	-----	> 1 min.	0.8 – 0.9 pu
Sustained Interruption	-----	> 1 min.	0.0 pu
Typical Causes	Motor starting, load variations.		

2.2.4 Voltage Imbalance

This is the maximum deviation among the three phases from the average three-phase voltage divided by the average three-phase voltage. The ratio of the negative or zero sequence components to the positive sequence component is usually expressed as a percentage. Typical deviation values are 0.5 – 2% [1]. Single-phase loads on three-phase circuits are the primary source of voltage imbalance.

2.2.5 Waveform Distortion

This is a steady-state deviation from an ideal sine wave of power frequency, principally characterized by the spectral content of the deviation. There are five types of waveform distortion [1]:

2.2.5.1 DC Offset

DC Offset is defined as the presence of a DC voltage or current in an AC power system. This phenomenon can occur as the result of a geomagnetic disturbance or be due to the effect of half-wave rectification. Incandescent light bulb life extenders, for example, may consist of diodes that reduce the RMS voltage supplied to the light bulb by half-wave rectification. Direct current in alternating current networks can be detrimental due to an increase in transformer saturation, additional stressing of insulation, and other adverse effects.

2.2.5.2 Harmonics

Harmonics are sinusoidal voltages or currents having frequencies that are integer multiples of the frequency at which the supply system is designed to operate. Harmonics combined with

the fundamental voltage or current can produce waveform distortion. Harmonic distortion exists due to nonlinear characteristics of devices and loads on the power system. Voltage distortion results as these currents cause nonlinear voltage drops across the system impedance.

Harmonic distortion is a growing concern for many customers and for the overall power system due to increasing application of power electronics equipment. Harmonic distortion levels can be found throughout the complete harmonic spectrum, with the magnitudes of each individual harmonic component varying inversely with their position in the spectrum. Furthermore, the phase angle of each component is unique unto itself. It is also common to use a single quantity, the *total harmonic distortion (THD)*, as a measure of the magnitude of harmonic distortion. More details will be shown in chapter 3.

2.2.5.3 Interharmonics

Interharmonics are defined as voltages or currents having frequency components that are not multiples of the frequency at which the supply system is designed to operate. Interharmonics can be found in networks of all voltage classes. They can appear as discrete frequencies or as a wide-band spectrum. The main sources of interharmonic waveform distortion are static frequency converters, cyclo-converters, induction motors, and arcing devices.

2.2.5.4 Notching

Notching is a periodic voltage disturbance caused by the normal operation of power electronics devices when current is commutated from one phase to another. Voltage notching represents a special case that falls between transients and harmonic distortion. Three-phase converters that produce continuous DC current are the most common cause of voltage notching.

2.2.5.5 Noise

Noise is unwanted electrical signals with broadband spectral content lower than 200 kHz superimposed upon the power system voltage or current in phase conductors, or found on neutral conductors or signal lines. Noise in power systems can be caused by power electronics devices, control circuits, arcing equipment, loads with solid-state rectifiers, and switching power supplies. Noise problems are often exacerbated by improper grounding.

The problem can be mitigated by using filters, isolation transformers, and certain line conditioners.

The general characteristics of waveform distortions are shown in Table 2.5.

2.2.6 Voltage Fluctuations (Flickers)

Voltage fluctuations are systematic variations of the voltage envelope or a series of random voltage changes. Their magnitude does not normally exceed 0.9 to 1.1 pu. The main sources of voltage fluctuations are continuous rapid variations of loads. Continuous variation in the current magnitudes can cause voltage variations that are often referred to as *flicker*. The term *flicker* is derived from the impact of the voltage fluctuation on lighting intensity. One of the most common causes of voltage flickers is the arc furnace. The flicker signal is defined by its RMS magnitude expressed as a percentage of the fundamental.

Table 2.5: Characteristics of Waveform Distortion and typical causes

Waveform Distortion	Typical Spectral Content	Typical Duration	Typical Voltage Magnitude
DC offset	-----	steady state	0 – 0.1 %
Harmonics	0 – 100 H	steady state	0 – 20 %
Interharmonics	0 – 6 kHz	steady state	0 – 2 %
Notching	-----	steady state	-----
Noise	broad-band	steady state	0 – 1 %
Typical causes	Non-linear loads, system resonance		

2.2.7 Power Frequency Variations

The power system frequency is directly related to the rotational speed of the generators on the system. At any instant, the frequency depends on the balance between the load and the capacity of the available generation. When this dynamic balance changes, small changes in frequency occur. The size of the frequency shift and its duration depend on the load characteristics and the response of the generation system to load changes.

Frequency variations that go outside of accepted limits for normal steady-state operation of the power system are normally caused by faults on the bulk power transmission system, a large block of load being disconnected, or a large source of generation going off-line.

Frequency variations that affect the operation of rotating machinery, or processes that derive their timing from the power frequency (e.g., clocks), are rare on modern interconnected power systems. Frequency variations of consequence are much more likely to occur when such equipment is powered by a generator isolated from the utility system. In such cases, governor response to abrupt load changes may not be adequate to maintain them within the narrow bandwidth required by frequency-sensitive equipment.

Some typical power quality disturbance waveforms have been illustrated in figure 2.1.

Table 2.6: Characteristics of Voltage Imbalance, Voltage Fluctuations, and Power Frequency

PQ Disturbances	Typical Spectral Content	Typical Duration	Typical Voltage Magnitude
Voltage Imbalance	-----	steady state	0.5 – 2 %
Voltage Fluctuations	< 25 Hz	intermittent	0.1 – 7 %
Power Frequency Variations	-----	<10 s	-----
Typical causes	Single phase load, load variations, load shutdown		

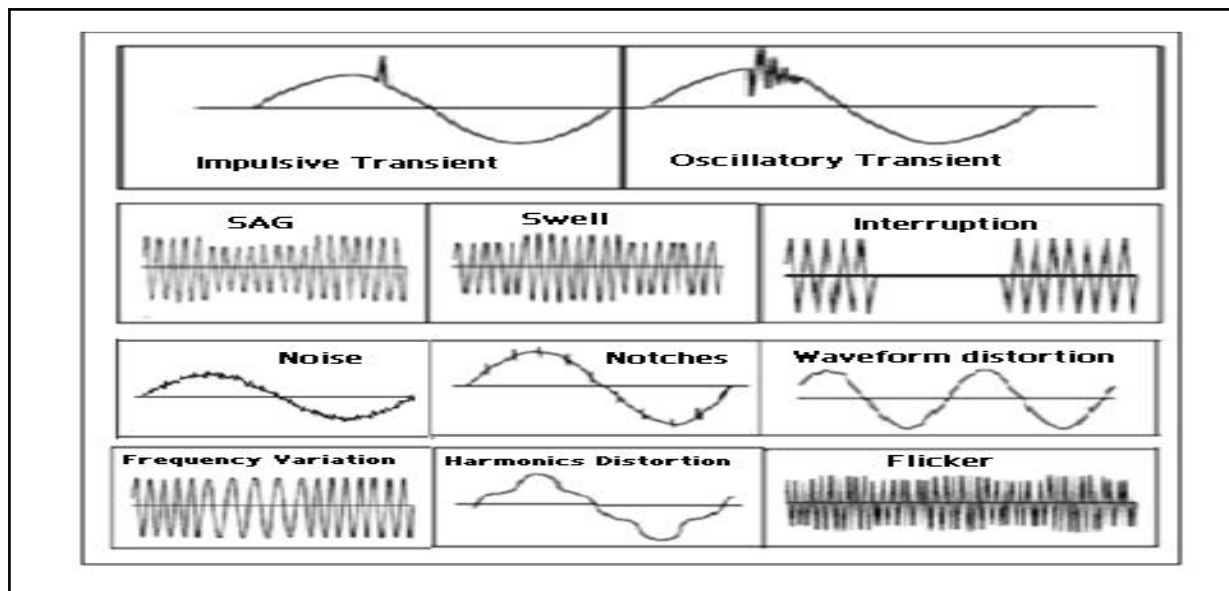

Figure 2.1: Typical PQ disturbances waveforms adopted from [48]

Each classification category has its own technical features, which can be considered the key to detecting and identifying the different types of disturbances in electrical systems. For instance, voltage sags or voltage swells can be detected by noticing the variation in the voltage magnitude for a specific duration. In addition, the mitigation techniques are different regarding different kinds of disturbances; for example, voltage sags can be mitigated by using various energy storage technologies or Uninterruptable Power Supply (UPS) systems, while under-voltage disturbances can be mitigated using voltage regulators. Monitoring power quality problems is an essential step toward mitigating these disturbances. In order to solve different power quality problems, the electrical system should have a monitoring system that can detect, analyze, and characterize different types of power quality disturbances.

2.3. Power Quality Monitoring

Power quality monitoring is necessary to characterize power quality disturbances at a particular location on an electric power system. Under deregulation, the necessity of monitoring is increased due to the difficulty of diagnosing incompatibilities between the electric power supply and the load. Moreover, the need to study distortion levels at particular locations is very important to refine modeling techniques or to develop a power quality baseline. Monitoring may be used to predict the future performance of load equipment or power quality mitigating techniques [1]. However, the most important reason to monitor power quality is to prevent the economic damage produced by power quality disturbances in critical process loads. The frequency of power quality disturbances and their duration can affect power quality costs. A more reliable and clean system is more expensive to build and operate.

Power quality monitoring is the process of collecting, analyzing, and interpreting raw data into useful information. The process of collecting data is usually carried out by continuous measurement of voltage and current over an extended period. The process of analysis and interpretation has traditionally been performed manually, but recent advances in the signal processing and artificial intelligence fields have made it possible to design and implement intelligent systems to automatically analyze and interpret raw data with minimal human

intervention [18]. The main objective of data collection is to identify and control the source of disturbances. This can be done by first detecting, analyzing, and characterizing different power quality disturbances.

2.3.1. Detection Process

The detection process is the first step in dealing with power quality problems. It is an online process that determines the start and end points of the disturbance. So, any voltage or frequency variations which exceed predetermined threshold must be identified. The same criteria used for classifying power quality disturbances, frequency components, and voltage/current magnitudes are used to detect power quality disturbances. The techniques used in the detection process are time-dependent. Time-dependent techniques require sample data that can be compared with threshold, and the sampling rate can affect the accuracy of detection.

The simplest detection method is to identify any deviation of time-dependent RMS voltage/current magnitudes from the nominal waveform. The disturbance start and end points are then detected by comparing the change in magnitude with a predetermined threshold. This method has been used for detecting voltage dips, swells, and interruptions. Another method is to use high pass or band pass filters followed by detecting step changes or oscillations. A disturbance in a power system often results in a fast step change (in voltage or current), and also results in high-frequency oscillations. A high pass filter can thus be used to detect such step changes or oscillations. Many studies have been conducted, mainly using wavelets, and are common in the literature [17]. Wavelet filters are known to be effective in detecting multi-scale singular points. As a result, wavelet filters can detect the start and end points of a disturbance which are usually related to significant sudden changes or singularities in the signal waveform [17].

2.3.2. Signal Analysis

This is the second step for monitoring power quality disturbances. It involves signal processing techniques in order to analyse the detected disturbance signals. The main objective of the analysis procedure is to justify the disturbance signal's features. These features can lead to the identification of the type of disturbance that occurred, and the more features justified from the signal analysis the more accurate disturbance identification.

There are many signal processing techniques that have been used to analyse the disturbance signals; a quick review of some techniques is presented below.

Fast Fourier Transform (FFT)

FFT is a basic method used widely in signal processing. FFT is applied to extensive data that has been selected based on various measurements. The FFT spectrum is normally used for detecting dominant harmonics, inter-harmonics and their related magnitudes.

Short-Time Fourier Transform (STFT)

STFT provides time-frequency signal decomposition, which is equivalent to applying a set of equal-bandwidth sub-band filters. STFT is a Fourier-related transform used to determine the sinusoidal frequency and phase content of local sections of a signal as it changes over time. Continuous STFT and discrete STFT are examples of short-Time Fourier Transform.

Wavelet Transforms

The wavelet transform is a significant tool for monitoring power quality problems. This technique is used to decompose the signal into different frequency bands and study its characteristics separately. A wavelet transform using the multi-resolution signal decomposition technique is efficient in analyzing the transient events. The multi-resolution signal decomposition has the ability to detect and localize the transient events and furthermore classify different power quality disturbances. The wavelet transform can be used to find unique features for different power quality disturbances.

Kalman Filters

The Kalman filter is an efficient algorithmic filter that estimates the state of a linear dynamic system from a series of noise measurements. Kalman filters are used to estimate the time-dependent signal components, magnitudes, and frequency components using selected harmonics frequencies.

There are other kinds of transforms and filters that have been applied to power quality problems; however, research on power quality problem analysis is still developing. After data have been analyzed, these data are characterized into specific classes to extract information about the type of power quality disturbance.

2.3.3. Disturbances Characterization

Disturbances characterization is the process of categorizing power quality disturbance signals into different types according to their features. Defining and extracting good-quality features is the essential analysis step in successful disturbances characterization. Disturbances characterization is still a focus research area. Different types of characterization methods have been applied to power quality disturbances; Expert System, ANN, and SVM have been highlighted below:

Expert System

An expert system applies deterministic approaches for categorization. The core of an expert system is a set of rules, where the “real intelligence” from human experts in power systems is translated into the “artificial intelligence” in computers. The performance of categorization is substantially dependent on the selected rules, a set of IF-THEN rules, and the inference engine that performs the reasoning of rules. The main disadvantage of the expert system is the need for a predetermined threshold value in order to make binary decisions, and choosing undesirable thresholds leads to less accurate categorization.

Artificial Neural Networks

ANNs have been an important tool for the statistical-based categorization of power system disturbances. The ANN is applied to extensive input and output data in order to find a relationship between the two, and it can be used to find patterns in data. Neural networks are nonlinear statistical data modeling tools. Categorization using neural networks is a good alternative when enough data is available.

Support Vector Machines

A Support Vector Machine (SVM) performs classification by constructing an N -dimensional hyper-plane that optimally separates the data into two categories. SVM models are closely related to Neural Networks. Using a kernel function, SVMs are an alternative training method for polynomial and radial basis functions, and multi-layer classifiers in which the weights of the network are found by solving a quadratic programming problem with linear

constraints, rather than by solving a non-convex, unconstrained minimization problem as in standard neural network training.

The power quality monitoring process, including its three steps, depends on power quality standards that define acceptable limits for the monitoring process. Starting from standard classification of power quality disturbances towards different threshold limits, power quality monitoring is useless if it is not compared to power quality baselines or standards. Power quality standards can set to define acceptable measurable limits of voltage, current, and deviations from normal frequency. The main benefits of PQ standards are to make clear to utilities and their customers the acceptable and unacceptable levels of service, and to protect the utility's and end user's equipment from failing or operating improperly when power quality disturbances occur.

2.4. Power Quality Standards

Various organizations have developed power quality standards. The Institute of Electrical and Electronics Engineers (IEEE), American National Standards Institute (ANSI), and Electric Power Research Institute (EPRI) are very famous in North America, whereas the International

Electrotechnical Commission (IEC) is a widely known organization in Europe.

IEEE power quality standards have focused on two main issues: First, that the utility has the responsibility to produce good quality voltage sine waves. Second, that end-use customers have the responsibility to limit the harmonic currents their circuits draw from the line at the point of common coupling (PCC). Unlike those of the IEEE, IEC power quality standards' main concern is the compatibility of end-user equipment with the utility's electrical supply system.

Utilities and end-users not only need standards that set limits on electrical disturbances that their equipment can withstand, but also standards that allow their various types of equipment to operate efficiently.

According to the EPRI, there are several types of power quality standards, and a comparison between the IEEE and the IEC for each type is illustrated in Table 2.7.

It is clear from the comparison that the IEC gives harmonics distortion more attention in their standards as compared to IEEE standards; nevertheless, the IEEE, in “*IEEE Recommended Practice for Monitoring Electric Power Quality, 1995*”, issued some harmonics distortion standards that are shown in Tables 2.8 and 2.9.

Table 2.7: Comparison of IEEE and IEC Power Quality Standards according to EPRI

IEEE Standards	PQ Disturbances	IEC Standards
None	Harmonic environment	IEC 1000-2-1/2
IEEE 519	Compatibility limits	IEC 1000-3-2/4 (555)
None	Harmonic measurement	IEC 1000-4-7/13/15
IEEE 519A	Harmonic practices	IEC 1000-5-5
ANSI/IEEE C57.110	Component heating	IEC 1000-3-6
IEEE 1250	Under-Sag-environment	IEC 38, 1000-2-4
IEEE P1346	Compatibility limits	IEC 1000-3-3/5 (555)
None	Sag measurement	IEC 1000-4-1/11
IEEE 446, 1100, 1159	Sag mitigation	IEC 1000-5-X
ANSI C84.1	Fuse blowing/upsets	IEC 1000-2-5
ANSI/IEEE C62.41	Over-surge environment	IEC-1000-3-7
None	Compatibility levels	IEC 3000-3-X
ANSI/IEEE C62.45	Surge measurement	IEC 1000-4-1/2/4/5/12
C62 series, 110	Surge protection	IEC 1000-5-X
By product	Insulation breakdown	IEC 664

The IEEE 519-1995 harmonic standard recognizes that the main source of harmonic currents is nonlinear loads located on the end-user side. However, the same standard indicates that the harmonic voltage can be amplified by capacitors located on the utility side. The utility can also transmit harmonic voltage distortion to other end users. As shown in Table 2.9, IEEE 519-1995 sets current limits at the point of common coupling (PCC), it

defines harmonic limits on the utility side based on the total harmonic distortion (THD) index, and on the end-user side as total distortion demand (TDD) index.

Table 2.8: Voltage harmonic distortion limits from IEEE Std. 519-1995

Bus Voltage at PCC	Individual Voltage Distortion	Total Voltage Distortion (THD)
69 kV and below	% 3.0	% 5.0
69.001 kV through 161 kV	% 1.5	% 2.5
161.001 kV and above	% 1.0	% 1.5

Table 2.9: Current Distortion Limits for General Distribution Systems from IEEE Std. 519-1995

Maximum Harmonic Current Distortion in Percent of I_L						
Individual Harmonic Order (Odd Harmonics)						
I_{SC}/I_L	$h < 11$	$11 < h < 17$	$17 < h < 23$	$23 < h < 35$	$35 \leq h$	TDD
< 20	4.0	2.0	1.5	0.6	0.3	5
20 < 50	7.0	3.5	2.5	1.0	0.5	8
50 < 100	10.0	4.5	4	1.5	0.7	12
100 < 1000	12.0	5.5	5	2.0	1.0	15
> 1000	15.0	7.0	6	2.5	1.4	20
➤ Even harmonics are limited to 25% of the odd harmonic limits above.						
➤ Current distortions that result in a DC offset, e.g., half-wave converters, are not allowed.						
Where I_{SC} : maximum short-circuit current at PCC. I_L : maximum demand load-current (fundamental frequency component) at PCC. TDD : total demand distortion.						

In contrast to the IEEE setting harmonic limits at the point of common coupling, the IEC sets, in IEC 1000-3-2 1995, harmonic limits on individual loads like adjustable-speed drives, and the IEC categorizes equipments into four classes. These limits are stated in Table 2.10.

Table 2.10: Harmonic Current emission limits from IEC 1000-3-2 Std. 1995

Class A Equipment		Class B Equipment		
Harmonics order (h)	Maximum permissible harmonic current (A)	Harmonics order (h)	Maximum permissible harmonic current (A)	
Odd Harmonics		Odd Harmonics		
3	2.33	3	3.5	
5	1.44	5	2.1667	
7	0.77	7	1.1667	
9	0.4	9	0.6	
11	0.33	11	0.5	
13	0.21	13	0.315	
15 ≤ h ≤ 39	$0.15 \times 15/h$	15 ≤ h ≤ 39	$0.225 \times 15/h$	
Even harmonics		Even harmonics		
2	1.08	2	1.62	
4	0.43	4	0.645	
6	0.3	6	0.45	
8 ≤ h ≤ 40	$0.23 \times 8/h$	8 ≤ h ≤ 40	$0.345 \times 8/h$	
Class C Equipment		Class D Equipment		
Harmonics order (h)	Maximum permissible harmonic current expressed as a percent of the input current at the fundamental frequency	Harmonics order (h)	Maximum permissible harmonic current per watt (mA/W)	Maximum permissible harmonic current (A)
2	% 2	3	3.4	2.33
3	% $30 \times PF$	5	1.9	1.44
5	% 10	7	1.0	0.77
7	% 7	9	0.5	0.4
9	% 5	11	0.35	0.33
11 ≤ h ≤ 39	% 3	13 ≤ h ≤ 39	$3.85/h$	$0.21 \times 13/h$
➤ Where PF: the circuit power factor				

The IEC 1000-3-2 std. 1995 sets limits for equipment harmonics current emissions, no matter which system they are connected to. The design of these nonlinear loads has to be controlled by standards, which are very important due to the large number of nonlinear loads connected to the systems. On the other hand, due to the sensitivity of computer equipment to voltage variations, the Computer Business Equipment Manufacturers Association (CBEMA), in the seventies, developed a curve that shows the range of acceptable power supply voltages for computer equipment. In the 1990s, the Information Technology Industry Council (ITIC) further developed a curve previously originated by a group from CBEMA. Recently, the ITIC curve (Figure 2.2) has replaced the CBEMA curve in general usage for single-line systems.

The purpose of power quality standards is to protect utilities' and end-users' equipment from failing or malfunctioning due to any voltage, current, or frequency deviation. The necessity of power quality standards has increased under deregulation. So, the energy injected or absorbed into or from the network has to be within acceptable limits in order to protect the deregulated system from any disturbances.

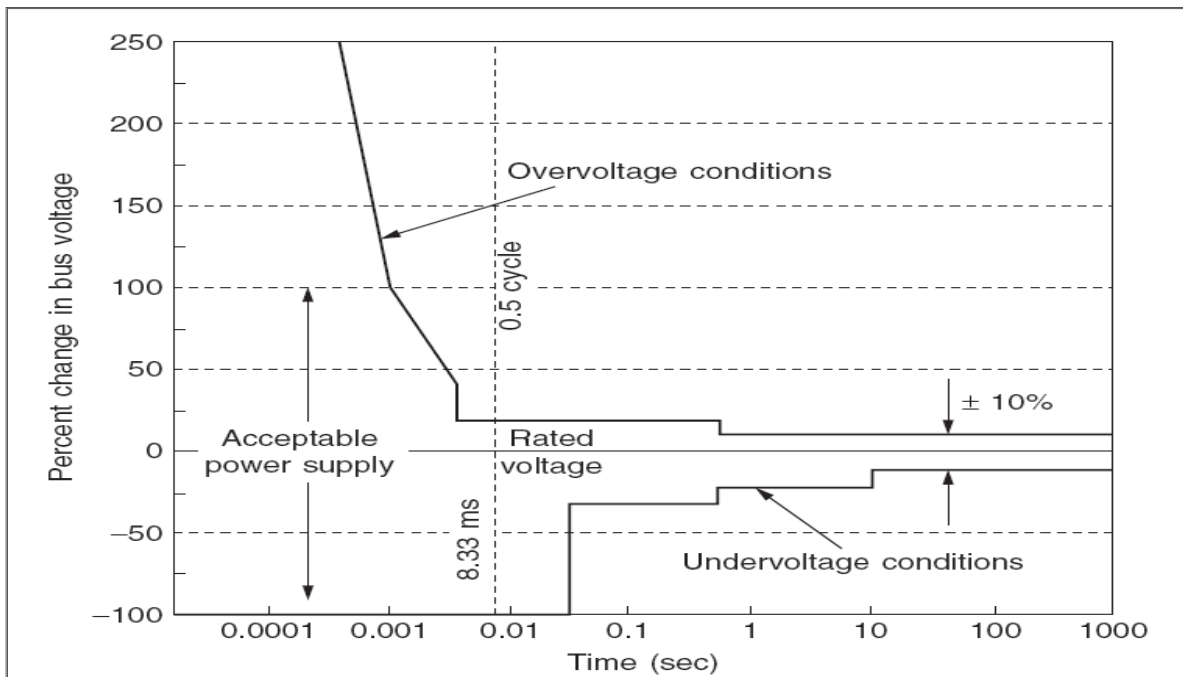

Figure 2.2: The ITIC curve adopted from [15]

Utilities in deregulated systems can no longer deal with power quality problems as a single entity. Thus, identifying who is responsible for any power quality problem will be a very important task in mitigating that problem. Moreover, the increase in nonlinear loads, which are sources of harmonic currents, makes the identification too complex. However, the impact of harmonics currents is increased due to the new structure of the system. These two important topics, the impact of harmonics pollution and the sources of harmonics, will be discussed in chapter 3.

Chapter 3

Harmonics Pollution

Harmonics are sinusoidal voltages or currents with frequencies that are integer multiples of the fundamental power frequency, which might be 50 or 60Hz. These waves result when the current waveform changes slightly due to nonlinearity of the load. Adding these harmonics to the fundamental current causes a distortion in the current waveform, and this distorted current produces distorted voltage over the system impedance which can be presented to end users. The current and voltage distortion is usually called *Harmonics Pollution* in the power system. Harmonic frequencies from the 3rd to the 25th are the most common ones measured in electrical distribution systems [1].

Currently, the structure of distribution systems tends to be formed of linear and modern electronic equipment such as personal or notebook computers, laser printers, digital TVs, adjustable speed drives, variable frequency drives, battery chargers, UPSs, and any other equipment powered by a switched-mode power supply. These non-linear power supplies draw current in short, high-amplitude pulses. These current pulses create significant distortion in the electrical current and voltage wave shape. The new load structure increases the vulnerability of the distribution system to harmonics distortion; as a result, many types of equipment will be affected. For instance, the protective relays may work inappropriately by tripping falsely, or not tripping when they should. Moreover, harmonics distortion can affect the accuracy of measuring devices, and this problem will get more attention when *Smart Grid* takes its place in the distribution systems. So, the measuring devices must be smart enough to mitigate the harmonics problem before taking measurements, which is not an easy task. The electrical power principles are not usually sufficient for solving harmonics problems due to the electrical power principles being mainly based on the fundamental frequency.

Harmonics distortion is not a new term in power systems, but the concern over power quality problems resulting from harmonics distortion will increase in the near future, following the restructuring of the distribution systems. Therefore, it is important to know how this distortion happens, how it can be measured, and what happens if the harmonics distortion increases beyond certain limits in the distribution system.

3.1. Harmonics Distortion

There are two types of waveform distortion: periodic and non-periodic. Harmonics are considered the major source of periodic waveform distortion. Harmonics distortion is the change in supply waveforms from the ideal sinusoidal waveform. Because of the periodicity, harmonics distortion can be expressed as a summation of sinusoidal waves (figure 3.1). The sum of sinusoids is referred to as a *Fourier series*. Harmonics problems are normally analyzed using Fourier analysis, so the system can be analyzed for each harmonic separately, which is much easier than analyzing the distorted waveform itself [1]. The distortion starts when non-linear loads distort the fundamental sinusoidal current. This distorted current is conducted through the system network, and when distorted current travels through the linear components in the system network, it produces distorted voltage. Obviously, current harmonics and voltage harmonics are related, but their effects are different.

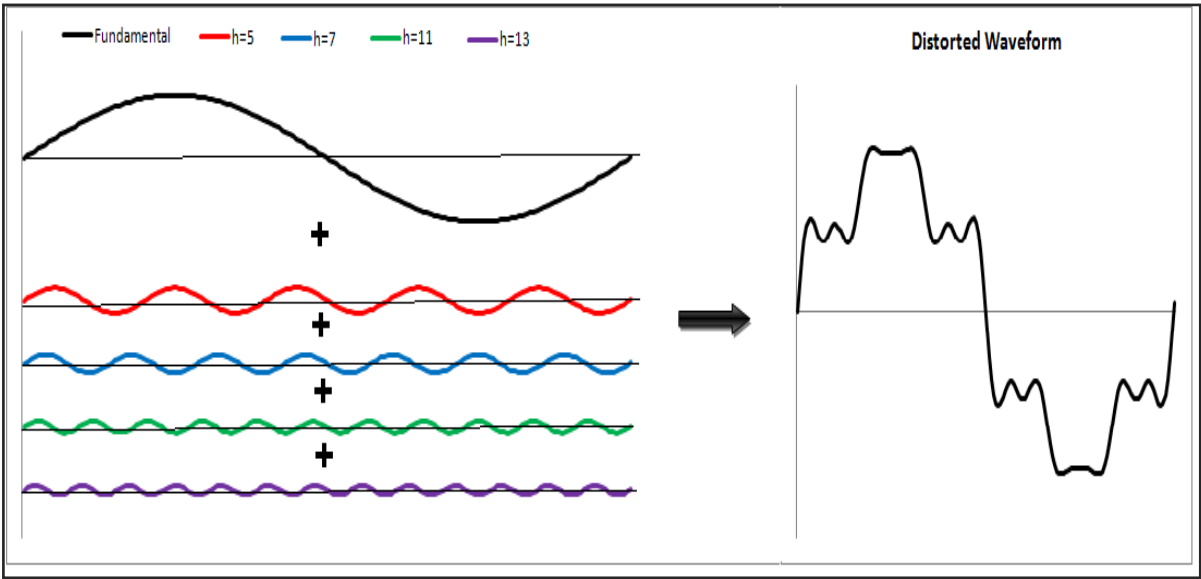

Figure 3.1: Fourier series representation of a distorted waveform

Current harmonics affect the distribution system by loading the system when the waveforms of other frequencies use the same system capacity without contributing any power to the load. They also increase the system copper losses. However, current harmonics cannot affect directly the linear loads in the system; only the non-linear loads that cause current harmonics are affected. On the other hand, voltage harmonics affect the entire system, not just the non-linear loads, and their impact depends on the distance between the power source and the harmonics-causing load. Moreover, all harmless loads connected to the same power source are affected by the voltage harmonics. So, the direct impact of the voltage harmonics distortion is more harmful than the direct impact of current harmonics distortion, whereas the current harmonics and system impedance are the real reasons behind voltage distortion consequences.

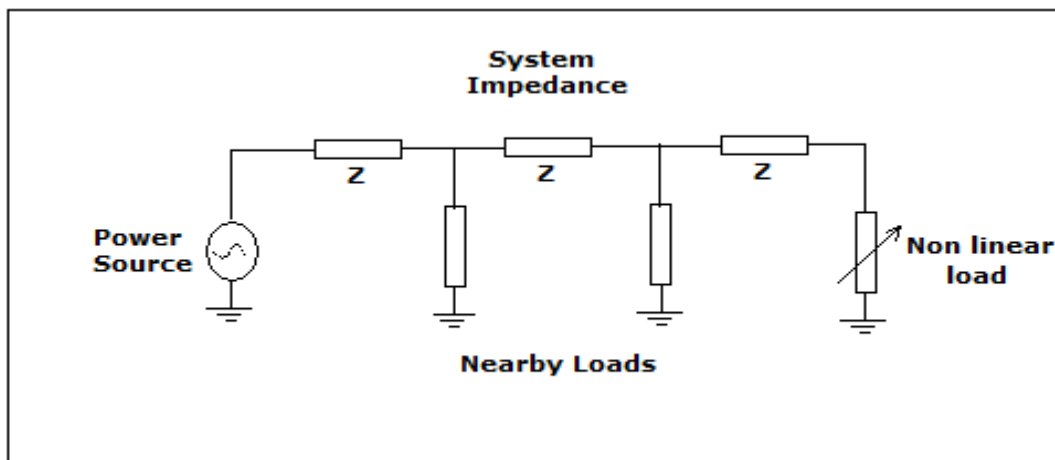

Figure 3.2: Simple network with non-linear load connected to sinusoidal power

It should be mentioned that variation in loads does not affect the voltage harmonics. If the same load is placed in two different positions on the power system, however, it will result in two different voltage distortion values. Thus, only the utility has control over voltage harmonics, which can be done by controlling the system impedance [1].

Because of the direct impact of voltage harmonics distortion on the quality of the distribution system, disturbances caused by voltage harmonics have gotten more attention in solving and mitigating those disturbances. However, whereas some mitigation techniques use electronics converters to solve voltage harmonics from one side, they increase the current harmonics from another side. The purpose of mitigation is to keep the voltage and current

harmonics distortion within threshold limits, and these limits are specified by the harmonics indices.

3.2. Harmonics Pollution Indices

To provide a reference guide for both utilities and their customers, many international standards have been proposed, such as IEEE-519 and IEC 61000-4-7. According to these standards, harmonics pollution should not exceed certain limits. These limits have been specified using harmonics indices. Total harmonics distortion (THD) and total demand distortion (TDD) are the most widely used harmonics indices.

3.2.1. Total Harmonics Distortion (THD)

According to IEEE-519, total harmonics distortion is defined as the summation of the effective value of the harmonics components in the distorted waveform relative to the fundamental component. It can be calculated for either voltage or current.

$$THD_v = \frac{\sqrt{\sum_{h=2}^{h_{max}} (V_h)^2}}{V_1} \quad (5.1)$$

Where V_h is the RMS value of voltage harmonics component h, while I_h is the RMS value of current harmonics component h; the THD for current is as follows:

$$THD_i = \frac{\sqrt{\sum_{h=2}^{h_{max}} (I_h)^2}}{I_1} \quad (5.2)$$

Most international standards use these indices to determine the total acceptable harmonics distortion limit and the individual harmonics distortion ratio for each effective harmonic; both individual and total harmonics distortion measurements should be within the standard limits. The voltage THD is applicable for defining harmonics levels on the utility side, while on the customer side the total demand distortion (TDD) is more applicable to limit the harmonic currents injected from the loads.

3.2.2. Total Demand Distortion (TDD)

Current distortion levels can be measured using the THD, but in the case of light loading, current THD will show at a high level due to the small current in the THD denominator. This measurement is misleading, because the high THD in the case of light loading is of no significant concern to the system. However, TDD uses the peak current load

in order to calculate the current distortion level; it is similar to calculating the THD, but the peak current load is used rather than the fundamental current in the TDD denominator.

$$TDD = \frac{\sqrt{\sum_{h=2}^{hmax} (I_h)^2}}{I_L} \quad (5.3)$$

Where I_L is the RMS value of peak demand load current, and I_h is the RMS value of harmonic current of h order. It is clear that when the THD measurements meet their limits, the TDD measurements should meet their limits too. Hence, in a situation where THD measurements have met their limits, using the TDD index is important.

The point of measurement in the TDD index is not the same in the IEEE-519 standard and IEC 61000-4-7. Standard IEEE-519 states that the measuring point is the point of common coupling (PCC) between the utility and the end-user, whereas IEC 61000-4-7 states that the measuring point is at the customer equipment terminal, so it determines the individual effect of each load in the distribution system. The variety of the harmonic current causes or sources makes meeting IEC 61000-4-7 standards a hard task when identifying the injected current harmonics from each load in the distribution system.

3.3. Harmonic Current Sources

The restructuring of the distribution system tend to be more efficient; however, the new structure has more harmonic current sources due to the modern electronic converters and microprocessors used in high-performance equipment. Harmonic currents can be produced from any non-linear load or from devices that contains electronic converters. In general, there are three sources of harmonic currents: residential and commercial loads, industrial loads, and control devices. In the next section, a quick review of some of these sources is presented.

3.3.1. Residential and Commercial Loads

The general trend of electrical power planners is toward energy conservation. Using high-efficiency lighting systems and adjustable-speed drives for heating, ventilation, and air conditioning (HVAC) loads is common in residential and commercial buildings, so there are many combinations of small harmonics-producing loads [1]. The distribution systems of most sites or facilities were never designed to deal with a large number of non-linear loads,

and most new building designs do not meet the new structure requirements. The problem gets worse when the usage of switch-mode power supply (SMPS) equipment or fluorescent lights is increased.

3.3.2. Industrial Loads

There are many harmonic current sources in industrial power systems. These include such general components as transformers. Transformer inrush currents contain significant levels of low-order harmonics. Moreover, the 3rd, 5th, and 7th-order harmonics are significant because they have large magnitudes, up to 10% of the magnetizing current, and they are very harmful under light load conditions. More significant harmonic sources come from applications of variable-speed drives that contain different kinds of three-phase rectifiers. DC drives have AC/DC converters that produce harmonics, whereas AC drive speed is controlled by converting AC to DC and then inverting DC to AC. Table 3.1 shows the amount of harmonic current that can be produced from a 150 HP, 6-pulse variable frequency drive (VFD) without any harmonics treatment, highlighted in [17].

Table 3.1: Current measurements on a 150HP, 6-pulse VFD with no harmonics treatment [17]

Load Condition	Currents (A)						THD _i	TDD
	RMS	60 Hz	5th	7th	11th	13th		
Full	233	182	118	80	12	12	79%	79%
75%	187	142	96	70	15	7	86%	65%
50%	134	96	69	54	17	5	96%	48%
25%	67	43	33	29	14	9	120%	30%

3.3.3. Control Devices

Control devices, such as a static Var compensator (SVC) and static synchronous compensator (STATCOM), use plus-width modulation (PWM) in order to control and support the system voltage. They work by reconstructing the voltage waveform by switching

back and forth from capacitive to inductive load. They control the voltage by supplying or absorbing reactive power from the system, therefore they are sometimes used as a mitigation technique for some voltage power quality disturbances; however, they produce harmonic currents in high-order frequencies, in switching frequency order. The magnitudes of these harmonics are very small, and their effects are very limited unless they are amplified by nearby power factor correction capacitors.

After this review of some harmonics sources, it is important to know how these harmonics affect the electrical power system and what the differences are between the effects of voltage harmonics and current harmonics. It has been mentioned previously that current harmonics and system impedance account for voltage harmonics, but what are the other impacts of current harmonics besides producing voltage harmonics?

3.4. Harmonics Pollution Impact Evaluation

Harmonic currents are unwanted waveforms travelling through the system network. They decrease the network system capacity by loading the network wires and equipments. They increase the total system copper losses and cause malfunctions in some electrical equipment. Moreover, they are blamed for producing the other type of harmonics, voltage harmonics, in the system. The electrical system is designed to function at the fundamental frequency. The response of the electrical system to harmonics is as important as identifying the harmonics sources. Knowing the impact of each harmonic on the different system components completes the way towards finding the best mitigation technique. The harmonics impact evaluations for capacitor banks, transformers, motors, and active harmonics filters are demonstrated in this section.

3.4.1. Capacitor Banks

Many industrial and commercial electrical loads have capacitors installed to compensate for low power factors. Most capacitors are designed to operate at a maximum of 110% of rated voltage and at 135% of their kVar ratings [16]. These limitations are normally overstepped in an electrical power system having a large amount of voltage, or current harmonics causing capacitor bank failures. Because of the inverse relationship between capacitive reactance and frequency, high-order harmonic currents can pass through capacitor

banks, thus the capacitor banks work as a sink for harmonic currents and so become overloaded.

Another harmonics impact on the capacitor bank is harmonic resonance. Resonant conditions are produced when the inductive reactance and capacitive reactance become equal. There are two types of harmonics resonance: series resonance and parallel resonance. Series resonance causes voltage amplification and parallel resonance accounts for current multiplication within an electrical system. In a harmonic-rich system, both types of resonance exist. During resonant conditions, the capacitor banks can be damaged when the amplitude of the unfiltered harmonics is large. Sometimes, this damage leads to harm on other electrical equipment in the system.

3.4.2. Transformers

The destructive effect of harmonic voltages and currents on transformer performance is often unseen until actual damage occurs. For example, transformers that have operated satisfactorily for a long time fail in a relatively short time when a load network is changed by installation of VFD, power factor correction capacitors, or arc furnaces. Transformers are designed to distribute the required power to the connected loads with minimum loss at fundamental frequency. Harmonic currents and voltages contribute to additional heating due to the overload. Causes of increased transformer heat include increased RMS current, eddy current losses, and core losses. Increasing the RMS current causes copper loss increases that result in heating up the transformers. The eddy current losses increase both as the square of the RMS current and the square of the original frequency. The increase in transformer eddy current loss due to harmonics has a significant effect on the operating temperature of the transformer. Transformers that are required to supply power to nonlinear loads must be derated based on the percentages of harmonic currents in the load current and the rated winding eddy current loss.

3.4.3. Motors

Voltage harmonics can significantly affect motors. Voltage delivered to a motor sets up magnetic fields in the core, which create iron losses in the magnetic frame of the motor. Hysteresis and eddy current losses are part of iron losses produced in the core due to the

alternating magnetic field. Hysteresis losses are proportional to frequency, and eddy current losses vary as the square of the frequency. Therefore, higher-frequency voltage components produce additional losses in the core of AC motors. The operating core temperature is increased, and the losses related to harmonic current circulation in the windings of motors are increased too. Lastly, voltage harmonics distortion can decrease motor efficiency, along with vibration, heating, and high noises.

3.5. Interharmonics

Interharmonics term is defined as: any frequency which is a non-integer multiple of the fundamental frequency. The order of interharmonics is given by the ratio of the interharmonics frequency to the fundamental frequency. If its value is less than one, the frequency is also referred to as a sub-harmonics frequency. IEC 61000-2-1 defines interharmonics as: *“Between the harmonics of the power frequency voltage and current, further frequencies can be observed which are not an integer of the fundamental. They can appear as discrete frequencies or as a wide-band spectrum”*. The basic sources of interharmonics are the side bands of the supply voltage and asynchronous switching in static converters such as PWM converters.

Many important issues related to harmonics pollution have been covered in this chapter. Voltage harmonics and current harmonics are the two types of harmonics pollution. Voltage harmonics distortion is responsible for many transient power quality problems, so voltage harmonics get more attention than current harmonics. The restructuring of the distribution system with an increase in non-linear loads creates more harmonic currents in the distributed environment. Current and voltage harmonics can be evaluated using different indices; THD and TDD. Voltage harmonics distortion is more important from the utilities' point of view, while keeping current harmonics distortion within limits in order to maintain good power quality is the main issue for end-users. Measuring current and voltage harmonics values is required in order to identify sources of distortion. Due to the relationship between voltage and current, a new term can be introduced, which is harmonics power. Harmonics power is a combination of voltage and current harmonics. How to monitor the harmonics power will be discussed in the next chapter.

Chapter 4

Monitoring Harmonics Pollution

4.1. Introduction

The harmonics currents injected into the system by non-linear devices are responsible for many harmonics distortions in the system, and they account for most voltage distortions due to the interaction between harmonic currents and the system impedance, as mentioned in the previous chapter. Therefore, to prevent or minimize the effect of distortion, the underlying causes must be eliminated or improved. The IEEE Std. 519 and the IEC 1000-3 have proposed standard limits for harmonic currents and voltages generated by customers and utilities, in order to limit the amount of harmonics pollution present in a distribution system. These standards have been widely accepted in industry, so power systems are designed to operate within these limits. However, to operate within the limits, customers have to reduce any injected harmonic currents which exceed the limits, and they have to prevent the system from any harmonic current frequencies near the system resonance frequency, which can increase the system's distortion level even if the harmonic currents are within the standards [21].

The standards help in limiting the harmonics pollution, but what happens if the limits are exceeded by a customer? The only enforcement option that the utility has is disconnecting that customer, which is not a desirable solution. Therefore, an incentive-based regulation has been proposed to charge the harmonics producers a penalty amount related to their harmonics pollution levels when the limits are exceeded. The incentive regulation is agreed by many as a solution to limit the harmonics pollution in a distribution system; however, the incentive regulation faces two technical problems: identifying the source of harmonics pollution in the distribution system, and isolating the effect of system impedance variation [5].

Both the identification of the harmonics pollution sources and the isolating of system impedance effectiveness can be handled by monitoring the harmonics pollution in the distribution systems. Monitoring the harmonics pollution can be achieved by first measuring

the harmonics distortion level of the electrical system, then identifying the source that is causing the distortion. Determining the source of any power quality problem by analysing its effects is a hard challenge faced by power quality engineers. An accurate measuring system is very necessary in order to get better analysis leading to correct identification. Two quantities have to be measured for the monitoring of harmonics pollution: voltage RMS and current RMS. RMS stands for the *root mean square* value. The root mean square value of voltage or current waveforms is equal to the waveform peak value over the square root of 2. Dealing with harmonics pollution requires measuring the true RMS value rather than taking the fundamental peak value. So the effect of harmonics should be taken into consideration in order to get accurate results, but where should the measuring points be?

The distorted voltages produced due to the interaction between harmonic currents and system impedance makes the system impedance play the main role in system analysis, not only for utilities but also for different types of customers. However, specifying or measuring the distribution system impedance is too hard to achieve due to the dynamic nature of the distribution systems. Thus, the harmonics pollution measurements must be taken in such a way that the system impedance effectiveness is implied. Figure (4.1) shows the equivalent representation of the distribution system as seen from the measuring point.

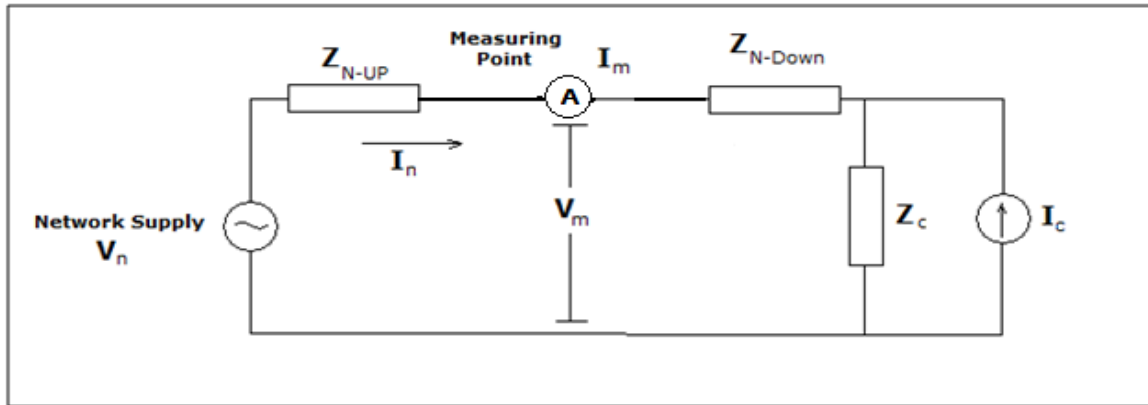

Figure 4.1: The equivalent representation of the distribution system seen by the measuring point

- V_N : the equivalent supply seen by the measuring point.
- Z_{N-UP} : the upstream network impedance seen by the measuring point
- Z_{N-Down} : the downstream network impedance seen by the measuring point
- Z_C : the customer impedance
- I_C : customer harmonic current
- V_M : the RMS voltage value at the measuring point
- I_M : the RMS current value pass-through the measuring point

It is clear from figure 4.1 that

$$\mathbf{I}_m = \mathbf{I}_n - \mathbf{I}_c \quad (4.1)$$

$$\mathbf{Z}_{N-UP} = \frac{\mathbf{V}_n - \mathbf{V}_m}{\mathbf{I}_n} \quad (4.2)$$

Equation 4.1 shows that the measuring current is the vector summation of the upstream network current (\mathbf{I}_n) and the customer harmonic current, assuming lossless system. So, any harmonic currents (upstream or downstream) should be considered as \mathbf{I}_m value. The amount of harmonic current (upstream and downstream) is affected by the system impedance, which includes the harmonics impedance; however, this effect will appear in both \mathbf{V}_m and \mathbf{I}_m . For instance, if the measuring point was near to the network supply, then the value of \mathbf{Z}_{N-UP} is going to be small and the voltage difference between \mathbf{V}_n and \mathbf{V}_m will be small, too; however, if the measuring point was located at a distance greater than in the previous case, $\mathbf{Z}_{N-UP_case2} > \mathbf{Z}_{N-UP_case1}$, then either the difference between \mathbf{V}_n and \mathbf{V}_m will increase or the value of \mathbf{I}_m will decrease, assuming same \mathbf{V}_n in both cases. Therefore, the effect of the system impedance variation in distribution systems can be isolated by taking the impact of this variation on the measured currents and voltages. In fact, the loss nature of the system affects the accuracy of the measuring system; nevertheless, this effect can be limited by minimizing the distance between the measuring points. In other words, the voltage at each bus and the current in each branch should be known. It is very costly to put measuring instruments at every single bus in the distribution system; however, using optimization techniques and some circuit analysis basics can reduce both the cost and the number of monitors installed. Before illustrating the allocation optimization technique, the configuration of the monitoring device is presented in section 4.2, in order to get an idea of its cost.

4.2. Harmonics Pollution Monitors

Monitoring harmonics pollution is the process of gathering, analyzing, and interpreting the measurement data in order to gain useful information. The first step in the monitoring process is gathering the measurement data, and this is carried out by continuous measurement of voltage and current signals over a specific period of time. According to Dugan, in [18], there are different types of power quality monitoring, such as monitoring to

characterize system performance, monitoring to characterize specific problems, monitoring to enhance power quality services, and monitoring as a part of predictive maintenance or site survey. There are two objectives for the monitoring of harmonics pollution system in distribution networks: characterizing the distortion levels and identifying the source of this distortion. The latter one will be discussed in detail in Chapter Five.

In order to characterize the currents and voltage distortion levels in distribution systems, harmonic currents and harmonic voltages have to be measured. It requires study-state sampling with results analysis. It can be accomplished by distributing harmonics pollution monitors in the system. Harmonics monitors are responsible for: measuring the true RMS values of voltage and current at the measuring point, then storing, analysing, and sending the data via the internet. The basic configuration of the harmonics monitor, adopted from [40], can be shown in figure 4.2.

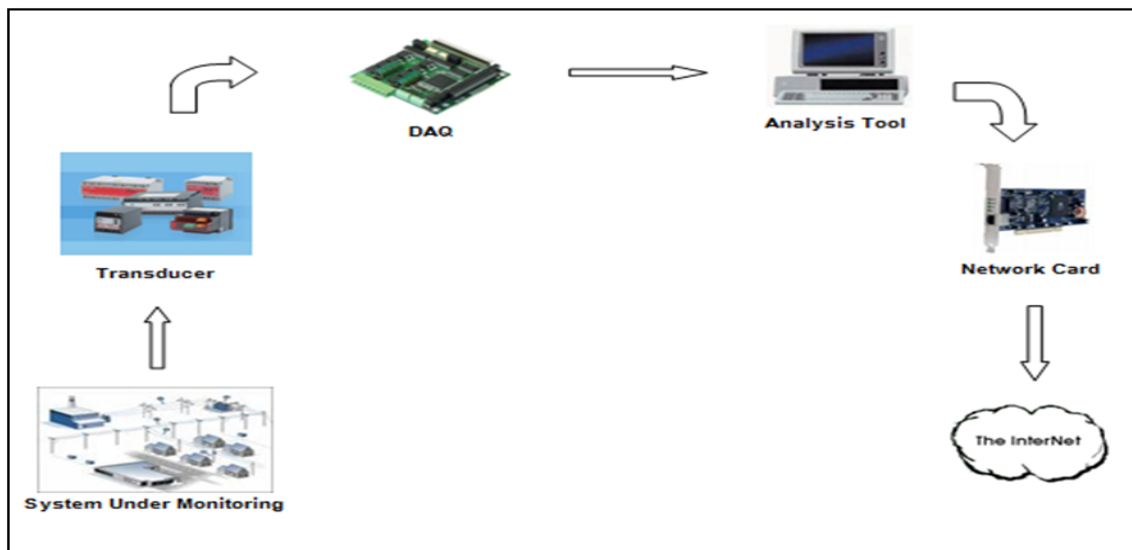

Figure 4.2: The basic configuration of harmonics pollution monitors [40]

4.2.1. Transducers

“It is a device that converts a physical quantity into an electrical signal. Typically, transducers are electromechanical energy conversion devices used for measurement or control. Transducers generally operate under linear input-output conditions and with relatively small signals.” The definition is taken from *Dictionary of Electrical Engineering* [17].

4.2.2. DAQ

The definition of Data Acquisition (abbreviated DAQ), according to [22], is: *the process of sampling of real world physical conditions and conversion of the resulting samples into digital numeric values that can be manipulated by a computer. Data acquisition typically involves the conversion of analog waveforms into digital values for processing. The components of data acquisition systems include:*

- *Sensors that convert physical parameters to electrical signals.*
- *Signal conditioning circuitry to convert sensor signals into a form that can be converted to digital values.*
- *Analog-to-digital converters, which convert conditioned sensor signals to digital values.*

A 14-bit analog-to-digital (A/D) board provides a sampling rate of 256 points per cycle for voltage and 128 points per cycle for current. This high sampling rate allows detection of voltage harmonics as high as the 100th and current harmonics as high as the 50th [18].

4.2.3. Analysis Tool (PC)

A personal computer can be used as an analysis tool and storage device for the measurements. Using different kinds of simulation software, such as C++ or MATLAB, is an efficient analysis technique that can be applied to the monitoring of harmonics pollution. A backup supply for the PC is an essential requirement in order to protect the monitoring system from any interruption. The security of the data is another requirement that can be maintained by the PC in order to send the data through the internet safely.

The overall harmonics monitor cost is shown in equation 4.3.

$$C_M = (L + 1) \times (C_{tran} + C_{DAQ}) + C_{PC} + C_{com} \quad (4.3)$$

C_M : the overall monitor cost, L : the number of current branches

C_{tran} : the transducer's cost

C_{DAQ} : the data acquisition card cost, depending on the sampling rate

C_{PC} : the cost of PC including memory card, simulation software, and security program

C_{com} : the communication facility cost, the Internet

A high level of accuracy in the harmonics monitors is a very important requirement; however, the cost of each high-efficiency monitor is going to be high due to the high sampling rate used. Moreover, the true RMS values of voltage and current in every single bus have to be known, and it is very costly to put a monitor in each bus. Moreover, the cost of the monitor itself can vary from one location to another due to the different number of required transducers for each location and the voltage level of that location; therefore, a location optimization technique has to be considered in order to reduce the number of installed monitors in the system, in such a way that monitors are able to observe the entire system's buses and branches.

4.3. Optimum Allocation of Harmonics Pollution Monitors

The IEC 61000-4-7 standards set the harmonic currents limits at the non-linear device terminals, no matter what system they are connected to. So, the design of the non-linear devices must be such that they satisfy the standards. The end-users' costs will be increased significantly in order to achieve the standards. Moreover, the utility can contribute to harmonics distortion, such as the harmonic currents produced from the SVCs in the transmission system, the harmonics distortion produced from HVDC converters, and the harmonics distortion produced from DGs. Therefore, the IEC standards must deal with harmonics distortion limitation for both utilities and customers.

The IEEE STD 519–1992 sets limits for both voltage and current harmonics at the point of common coupling (PCC). The IEEE working group defines PCC as: “*The Point of Common Coupling (PCC) with the consumer/utility interface is the closest point on the utility side of the customer's service where **another utility customer is or could be supplied**. The ownership of any apparatus such as a transformer that the utility might provide in the customer's system is immaterial to the definition of the PCC.*” A problem can occur when two loads sharing the same PCC interact and some of the harmonic currents produced from one load are absorbed by the other one (Figure 4.3). The ratio between the network harmonic impedance and the nearby load harmonic impedance determines the value of the harmonic currents absorbed by the nearby load. I_{c1} . Thus, the measured harmonic current at the PCC is not equal to the true harmonic currents produced by the non-linear load.

Distribution systems have high levels of interconnection between different types of customers; industrial, commercial, and residential, so identifying the source of harmonics pollution is a hard task in a system which has this kind of configuration.

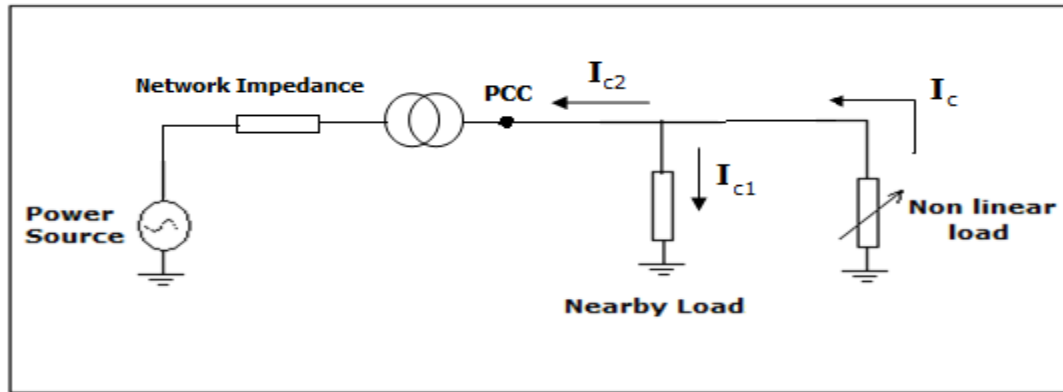

Figure 4.3: The interaction between two loads sharing the same PCC

In addition, all the newly-installed distributed generators make the situation harder. Monitoring of the system has been proposed as a solution to this problem [23 – 24]; however, it suffers from the high cost. The monitoring system cost can be reduced by installing the monitors in strategic locations, which can optimize the number of monitors and minimize the required input data. This thesis presents a novel approach for allocating monitors in the distribution system. The proposed approach is based on the graph-colouring optimization technique.

4.3.1. Graph-Colouring Optimization Technique.

Graph-colouring is a special case of graph theory; it is an assignment of labels, usually called "*colours*", to elements of a graph, subject to certain constraints. It is a method of colouring the vertices of a graph such that no two adjacent vertices share the same colour; this is called vertex colouring. Likewise, edge colouring assigns a colour to each edge so that no two adjacent edges share the same colour, and face colouring of a planar graph assigns a colour to each face or region so that no two faces that share a boundary have the same colour. Vertex colouring is the starting point of the colouring theory, and any other colouring problems can be converted to a vertex version. For example, edge colouring of a graph is just

a vertex colouring of its line graph, and face colouring of a planar graph is just a vertex colouring of its planar dual [22].

In mathematical and computer representations it is traditional to use the first few positive or nonnegative integers as the "colours"; for example, in a Register Allocation problem, which is the process of multiplexing a large number of target program variables onto a small number of CPU registers. The objective is to keep as many operands as possible in the registers to maximise the execution speed of software programs. Most computer programs need to route large numbers of different data items. However, most CPUs can only perform operations on a small fixed number of "slots", called registers. Even on machines that support memory operands, register access is considerably faster than memory access. Variables not allocated to registers must be loaded in and out of RAM whenever they are used [22].

In general, one can use any finite set as the "colour set". The nature of the colouring problem depends on the number of colours, but not on what they are. Graph-colouring applies to many practical applications as well as theoretical challenges. Beside the classic types of problems, different constraints can also be set on the graph, or on the way a colour is assigned, or even on the colour itself.

4.3.2. Problem Description

The proposed approach for allocating monitors is based on the Vertex-Colouring technique. Each voltage bus is represented by a vertex, and each current branch is represented by an edge. The goal of the optimization technique is to measure or calculate all state variables, i.e., true RMS voltages and currents, by minimum monitoring system cost. It starts by assigning one bus to a colour, A, that represents an installed monitor. Then, it tries to colour all the adjacent vertices in another colour, B, if the bus has satisfied constraints. The same rule is applied for edges. Edges represent the current branches in the system, so each branch should be measured or calculated. All branches connected to the bus having a monitor take the same colour, C, and then all branches that connect two coloured vertices or buses are given another colour, D. This procedure, of adding a monitor, will continue until all state variables are coloured. Therefore, knowing all state variables in the system, and

minimizing the number of buses that are assigned to colour A and the number of branches that are assigned to colour C, will lead to the minimum number of installed monitors. Monitor allocation is considered as a mixed-integer problem (MIP), because the solution to this problem is a combination of zeroes and ones, which are the binary variables in the objective function that indicates the monitors' locations.

4.3.3. Mathematical Formulation

The first step in the formulation is converting the real structure of the distribution system into a numerical form. This can be done using the *Existence Matrix*. The Existence Matrix is an integer representation of the Y-Bus matrix. The elements in the main diagonal of the Existence Matrix represent the number of current branches of each bus; however, the non-diagonal elements represent the connections between buses.

$$EM_{jk} = \begin{bmatrix} E_{11} & \cdots & E_{1k} \\ \vdots & \ddots & \vdots \\ E_{j1} & \cdots & E_{jk} \end{bmatrix} \quad (4.4)$$

EM_{jk} : the Existence Matrix of ($j \times k$) elements that represent the distribution system

E_{jk} : the Existence Matrix's elements that represent the voltage buses and current branches

The non-diagonal elements take either zero or one. If Bus_j is connected to Bus_k, then E_{jk} equals one, and if there is no connection between Bus_j and Bus_k, E_{jk} equals zero. An example of a 4-bus system is presented to clarify the Existence Matrix representation (Figure 4.4).

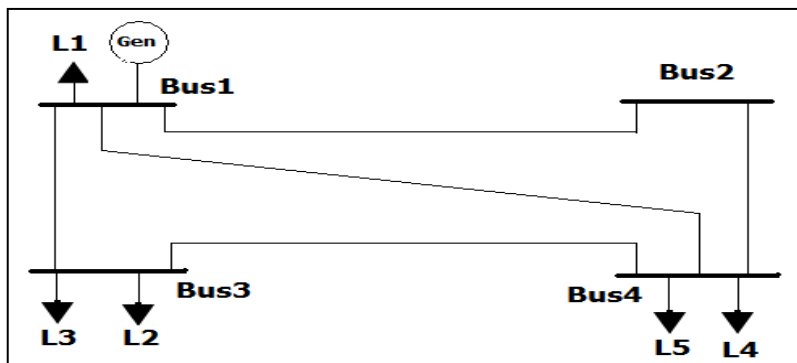

Figure (4.4): A typical Example of a 4-bus system

$$EM_{jk} = \begin{bmatrix} 5 & 1 & 1 & 1 \\ 1 & 2 & 0 & 1 \\ 1 & 0 & 4 & 1 \\ 1 & 1 & 1 & 4 \end{bmatrix} \quad (4.5)$$

The advantage of the Vertex-Colouring (VC) method in solving the monitors' location problem is the low required input data. It needs only the Existence Matrix as an input, and it can get from this matrix all the required data in order to solve the problem. The goal of the proposed method is to minimize the cost of the monitoring system. The covering and packing method minimizes the monitoring system based on minimizing only the number of monitors used, whereas the proposed VC approach minimizes the monitoring system cost by minimizing the number of monitors used and the monitor location cost (C_j), which is function of the number of branches at that location. Hence, the installed number of monitors and the number of current transducers and DAQs that are used in each monitor will be minimized, which leads to reducing the overall system cost. The objective function can be mathematically expressed as follows:

$$\mathbf{minimize} \sum_{j=1}^N C_j X_j \quad (4.6)$$

Where $X(j)$ is a binary vector that represents the existence of monitors in all N -buses. It is expressed as:

$$X(j) = \begin{cases} \mathbf{1}, & \text{if the monitor \#j is installed.} \\ \mathbf{0}, & \text{if the monitor \#j is not installed} \end{cases} \quad (4.7)$$

$C(j)$ is the cost vector of N -monitors. Each bus has a different cost of installing a monitor, related to the number of current branches that the bus has. Each branch needs a current transducer and a DAQ, and even if one can assume that the monitoring system has access to the distribution system's CTs, the cost of a highly accurate DAQ is still not avoidable.

N is the number of buses in the distribution system under monitoring.

The total cost of the monitoring system is the summation of the cost of installed monitors, given in (4.6), and the objective function should be minimized subject to observability constraints.

4.3.4. Observability Constraints

According to Eldery et al., in [25], the observability constraints guarantee that all of the state variables are measured or calculated by at least one monitor, and the constraints are obtained from Kirchhoff's Current Law (KCL) and Ohm's Law (OL), resulting in two groups of constraints.

Ohm's Law Constraints

Figure (4.5) shows a part of the distribution system which consists of two buses across a line. This part has three state variables, V_j , V_k , and I_{jk} , and knowing two of them leads to the ability to calculate the third by applying Ohm's Law.

$$V_j - V_k = I_{jk} \times Z_{jk} \quad (4.8)$$

- If V_j and I_{jk} are known, then V_k can be determined (Voltage constraint)
- If V_j and V_k are known, then I_{jk} can be determined (Current constraint)

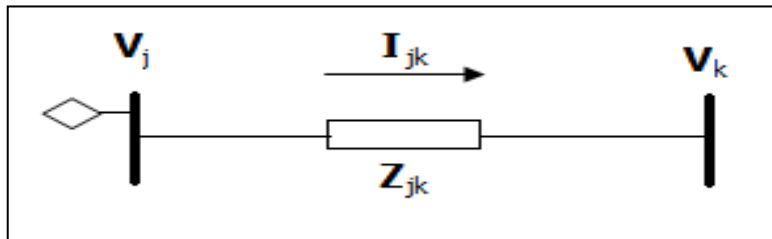

Figure (4.5): A part of the distribution system, consisting of a transmission line between two buses

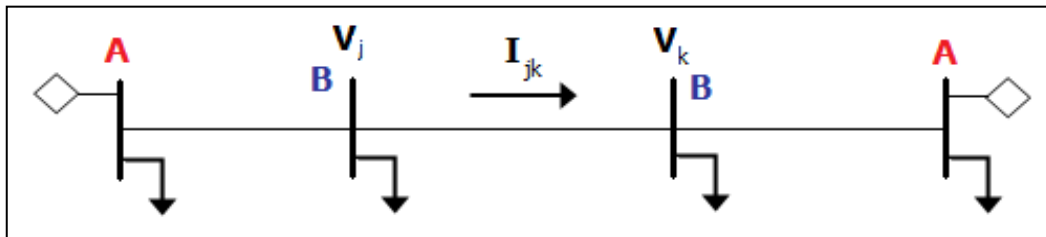

Figure (4.6): 4 buses are connected by lines as a part of the distribution system

In figure (4.6), a part of the distribution system has two monitors (rhombus), one at each end. V_j and V_k are observable according to the voltage constraint, so they are given

colour B. Because V_j and V_k are observable, I_{jk} can be observable too, according to the current constraint. Applying these constraints to the entire system buses, the number of buses that are taken colour A will be optimized in such way that all the state variables are still known.

Kirchhoff's Current Law (KCL)

Voltage and current constraints are applied for unknown load buses; however, some information about the loads can be found which can help in the allocation problem. According to Eldery, the buses whose load parameters are known are called the known buses, whereas a bus that has no load connected to it is called a connecting bus. All the known buses and connected buses should be known in order to reduce the number of installed monitors required. KCL states that “*the incoming and the outgoing currents at any bus are equal.*” Two extra constraints result from applying KCL: one for the known bus and the other for the connected bus.

Connected Bus Constraints

The definition of a connected bus is: a bus that is connected to neither the load nor the generator. It is easy to identify the connected bus by using the Existence Matrix, using the following equation:

$$\text{Bus \# } j \text{ is a connected bus if } (E_{jj} - \sum_{k=1}^N E_{jk}) = \text{zero} \text{ where } K \neq j. \quad (4.9)$$

Bus #2 in figure (4.4) is a clear example of a connected bus. The connected bus constraint is that if all the neighbouring buses to the connected bus are observable, then the connected bus is observable, too, and it is given colour B.

Knowing Bus Constraints

A known bus is defined as: a bus whose relation between load current and voltage is known. Assuming that Bus #4 is a known bus in figure (4.4), and then applying KCL to bus # 4:

$$\sum_{k=1}^N I_{jk} = I_j \quad \text{Where } K \neq j \quad (4.10)$$

$$I_{14} + I_{24} + I_{34} = I_{L4} + I_{L5}$$

If the lines impedance and load impedance are known then

$$\frac{V_1}{Z_{14}} + \frac{V_2}{Z_{24}} + \frac{V_3}{Z_{34}} = \frac{V_4}{L_4+L_5} \quad \text{Where}$$

$$\frac{1}{Z_{jj}} = \frac{1}{Z_j} + \frac{1}{Z_{1j}} + \frac{1}{Z_{2j}} + \frac{1}{Z_{3j}} + \dots \dots \quad (4.11)$$

Thus, if V_1 , V_2 , and V_3 are observable, then V_4 is observable, too, and it is given colour B.

In brief, if all buses connected to a known bus or connected buses are observable, then that bus is observable, too.

So, the formulation of the vertex colouring can be expressed as:

$$\left\{ \begin{array}{l} \min \sum_j C_j X_j \\ \text{Subject to} \\ \text{voltage constraints} \\ \text{current constraints} \\ \text{KCL constraints} \end{array} \right. \quad (4.12)$$

DATA REDUNDANCY

According to Eldery, it is always expected in monitoring problems that there is data redundancy, which means that some of the network voltages or currents can be measured or calculated from more than one monitor. Nevertheless, it is desirable to limit this redundancy. In this situation, the data redundancy is defined as: how many times the state variables are measured or calculated, and the data redundancy factor (DRF) is defined as:

$$DRF = \frac{\text{sum of the possible times that the state variable can be colored}}{\text{number of state variables}} \quad (4.13)$$

The data redundancy factor will equal one when there is no redundancy in the data; however, the higher the DRF, the higher the redundancy. The benefits of lower data redundancy are in the reduction of media to store the data, as well as that the bandwidth for sending and receiving these data between different monitors is reduced, too. On the other hand, the system reliability will be decreased when redundancy in the data is reduced [25].

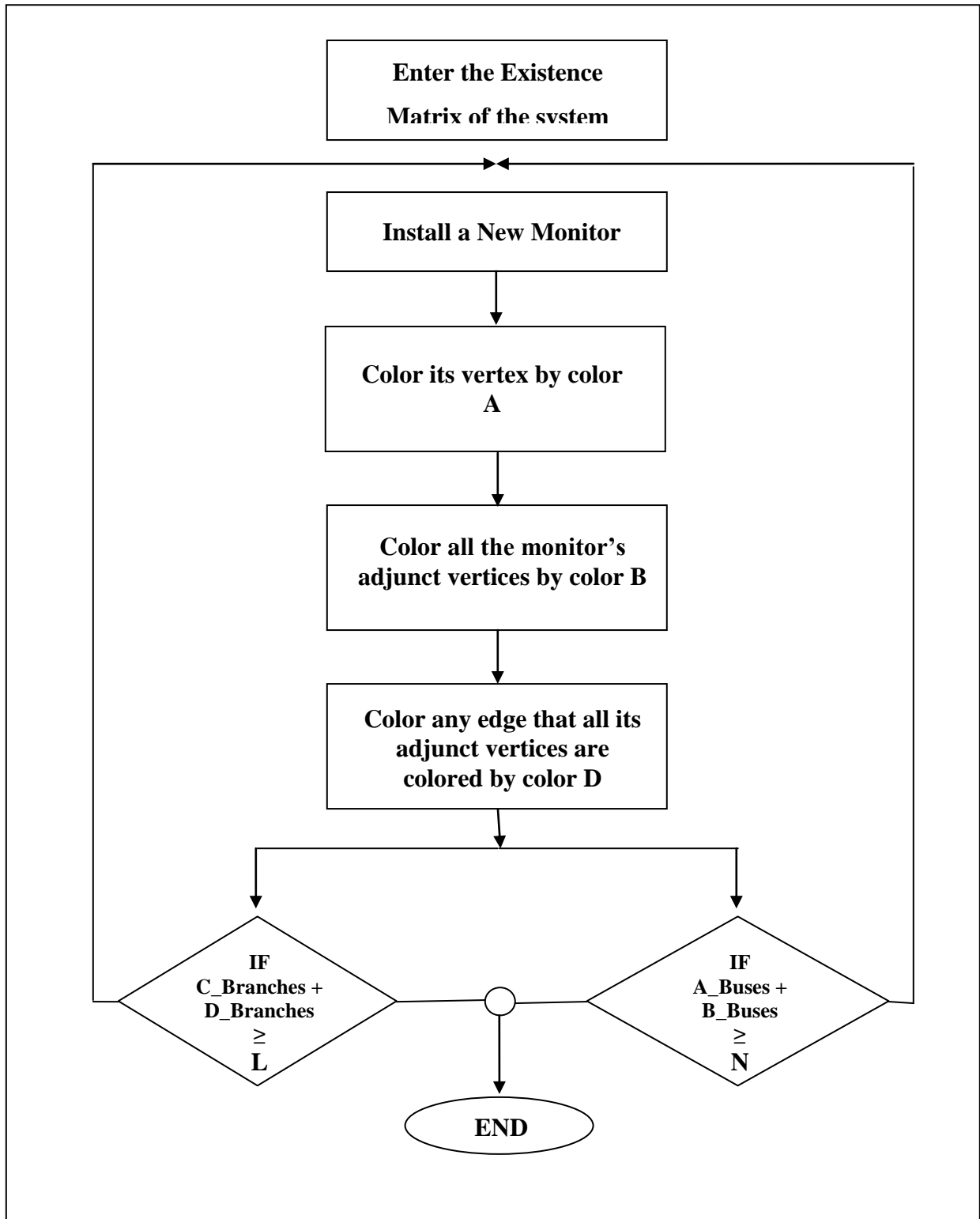

Figure (4.7): The flowchart of the Vertex – Coloring method that is applied for monitors’

4.4. Applications

The proposed Vertex – Coloring method has been applied to different systems, where *General Algebraic Modeling System* (GAMS) is used as the optimization package. The first case is a simple 4-bus system to illustrate the proposed method, and there is no information about the buses types. The second study is focusing on a system that has different kinds of buses: generation bus, load bus, and connecting bus. The second case will examine the KCL constraints on the same 4-bus system. Finally, the IEEE 30-Bus that is highlighted in [25] is presented and a brief comparison between Vertex – Colouring method and the packing and covering method, proposed by Eldery is presented. The output results of the two methods are in good agreement.

4.4.1. Case(1): 4 – Bus System

A four-bus system with five transmission lines was shown in Figure (4.4). The state variables are the bus voltages and the lines currents as indicated in the figure. In this case, it is assumed that no information is available about either the loads or the generation units (i.e., there is neither known bus-bars nor connecting bus-bars). The input data for GAMS is only the *Existence Matrix* that was shown in equation (4.5). Figure (4.8) shows the allocation of monitors in the 4 – bus system.

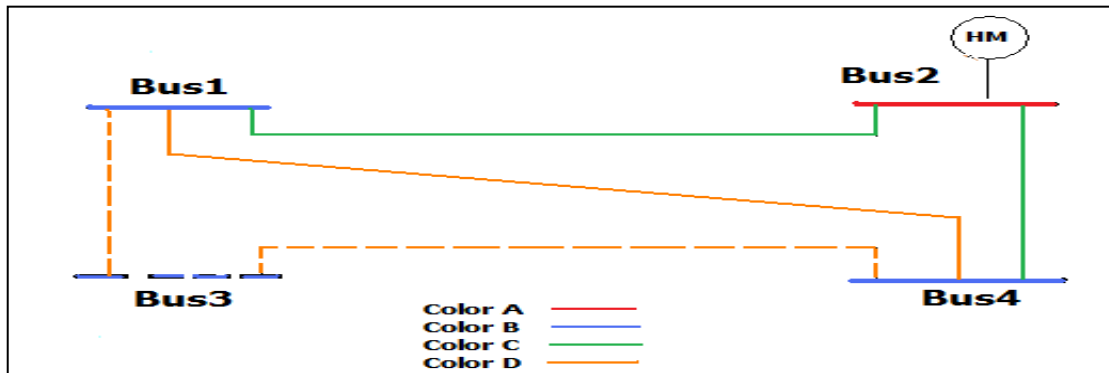

Figure (4.8): The allocation of harmonics monitor using the Vertex – Coloring
 Bus2 is given colour A because Bus 2 has a monitor on it, and Line (2-1) and Line (2-4) have been given colour C. Applying OL constraints, Bus 1 and Bus 4 are given colour B, and applying KCL constraints, Bus3 is given colour B, too, because all connected buses, Bus 1 and Bus 4, are observed, or coloured. Line (1-3), Line (1-4), and Line (3-4) are given colour D using OL constraints. This case has two optimum allocations: a monitor on Bus 2 or a

monitor on Bus 3. Both solutions have DRF equal to 1. The default for this system is to have four monitors (one at each bus), and the cost of this default system will equal the cost of 4 PTs (one for each bus) and the cost of 10 CTs (two for each line – from both ends); however, the reduction of the number of PTs and CTs used (from 4 PTs to only one and from 14 CTs to just two) decreases the cost up to 80%.

4.4.2. Case(2): 4-bus system with Loads and Generator

To show the effect of the KCL constraints, the second study case will be using the same four-bus system, but assuming that Bus 1 is a generation bus, Bus 2 is a connected bus, and Bus 3 and Bus 4 are unknown-load buses. In this case, the optimum allocation of the monitors is to Bus 1, Bus 3, and Bus 4. The generator and unknown-load currents force the installation of extra monitors in order to measure the currents drawn from Bus 1, Bus 3, and Bus 4. The result is shown in figure (4.9), and the cost is reduced by only 16.67%, which is the cost of one PT and two CTs in Bus 2; however, the DRF is increased to 1.77.

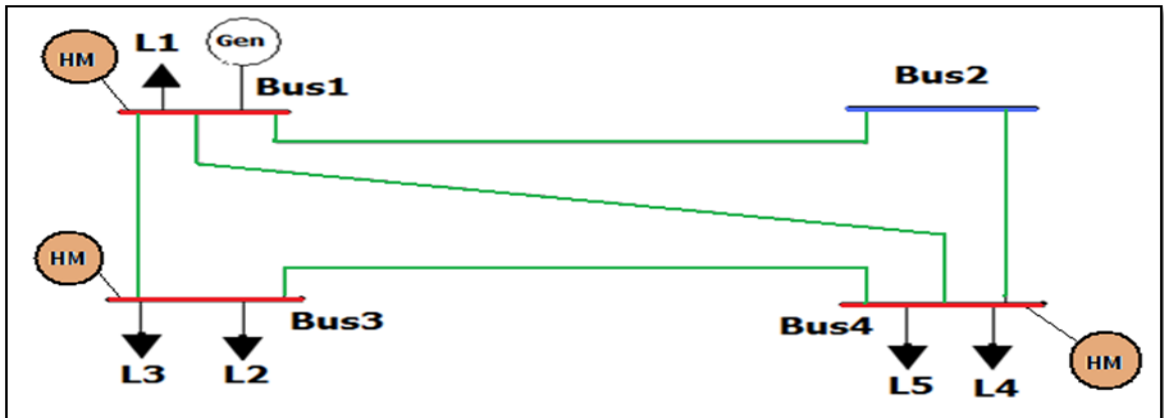

Figure (4.9): The allocation of harmonics monitors using the VC method on Case 2

When the end-users' loads are dynamic, the bus has to be monitored in order to measure the load currents for each branch. However; if the load has a static nature, the load's current can be calculated by observing only the bus voltage, because the relation between the bus voltage and the load current is known. Therefore, the type of loads connected to the end-users' buses have a crucial impact on the allocation problem. Considering the linear loads as known buses will enhance the performance of the monitoring system, whereas the impact of the linear load variations on the other buses should be examined.

4.4.3. Case (3): IEEE 30-Bus

For a more realistic study, the proposed algorithm is applied to the IEEE 30-bus that is highlighted in [25]. It is assumed that there is no information about either the generation buses or the load buses. The system and the monitors' allocation are shown in Figure (4.10), where the harmonics monitors are indicated by (HM), and the PQINs resulting from the Eldery method are indicated by a blue rhombus.

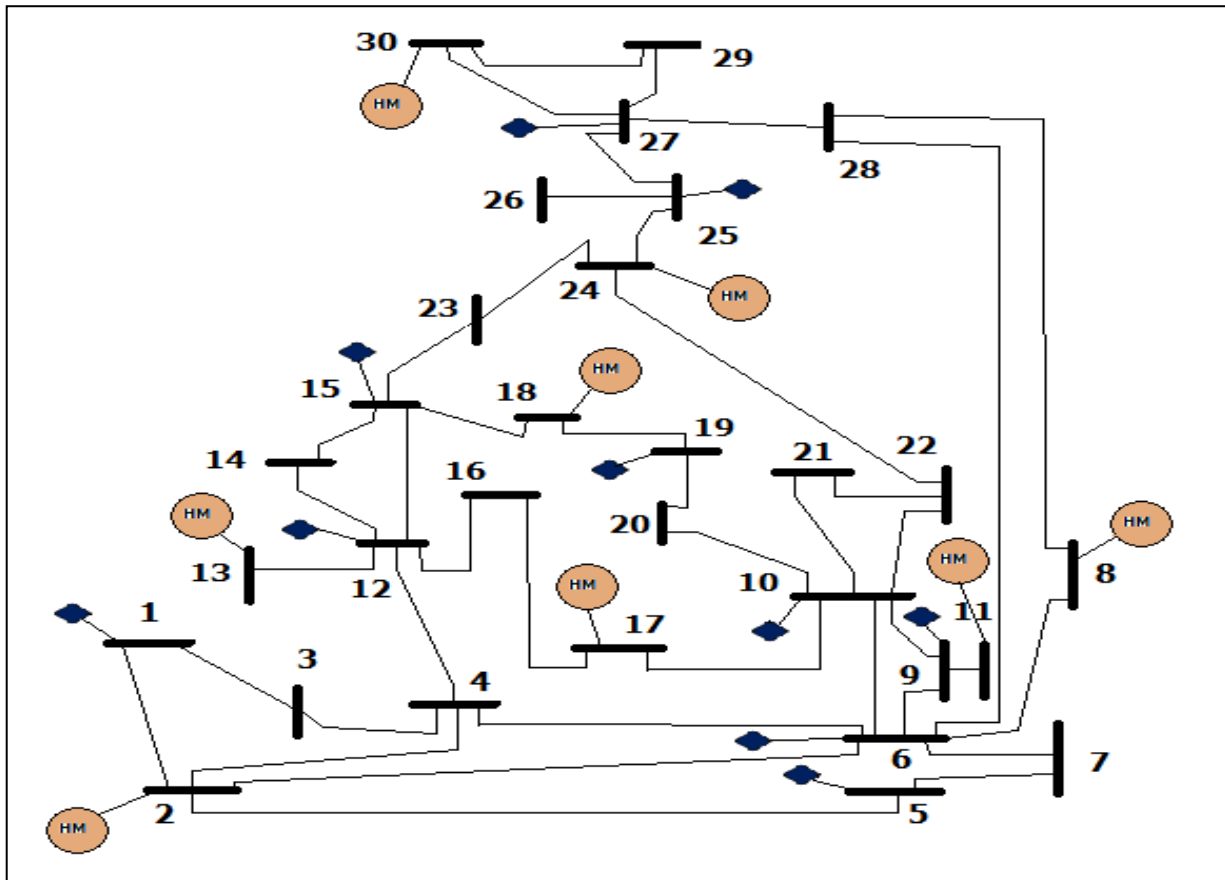

Figure (4.10): IEEE 30-bus system with the location of the PQIN indicated by the rhombus and Harmonics Monitors by HM in a circle

The result of the packing and covering method has shown a reduction of total cost by 54% by using 10 monitors, while the vertex-colouring method shows a 79% reduction of total cost by using only 8 monitors. Moreover, the DRF is found to vary between 1.643 and 2.155 using the packing-covering method, whereas using vertex-colouring gives DFR equal to 1.296.

The proposed vertex-colouring (VC) method shows better results than the packing-covering method, and the required input data for VC is very simple and available from the Y-Bus matrix and the single line diagram (SLD) of the system under monitoring. The redundancy of the data has better performance with large systems. The amount of cost reduction is decreased when the number of unknown buses (non-linear loads) in the system is increased. So, the nature of the distribution system under monitoring and the ratio of the unknown bus load to the total system buses can force the necessity of installing more monitors in order to detect all the harmonics-producing devices in the system. Thus, if the number of harmonics-producing devices is increased on the customer side, the number of monitors installed in this sector will be increased to gather all required information that can be used in the identification process. For a more practical study, the VC method is applied on the industrial IEEE 40-Bus system that contains several non-linear loads, to examine the effectiveness of VC in collecting sufficient data for the identification process. More details about the system and the VC method results are shown in the next section.

4.5. Description of the IEEE Std 399-1997 System

This system is the IEEE Recommended Practice for industrial and commercial power system analysis. This system is very applicable for techniques that are most commonly applied to the computer-aided analysis of electric power systems in industrial plants and commercial buildings. Summary of the system buses and the single line diagram of the system are shown in Table (4.1) and figure (4.11) respectively.

The system configuration and the transformer and transmission line data are presented in Table (4.2), adopted from the IEEE report [48]. Table (4.3) shows the generator and cable data of the IEEE 40-bus system. In order to apply the vertex-colouring method to the IEEE 40-Bus system, some of the buses have to be reordered and given different values than the IEEE Std. 399-1997, for the sake of simplicity. Table (4.4) presents the new order of the system buses.

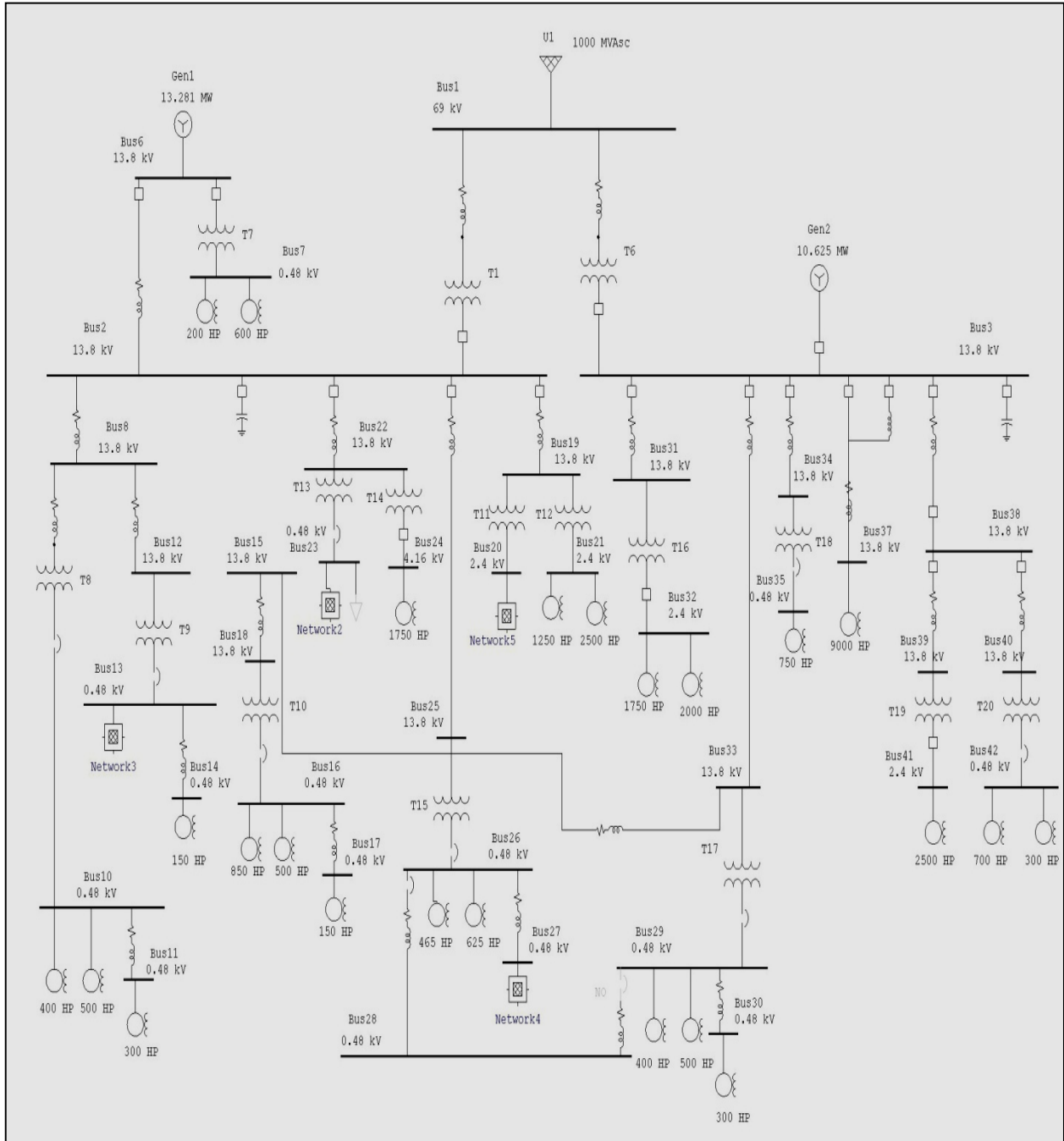

Figure (4.11): Single Line diagram of IEEE Std 399-1997 typical power system [48]

Table (4-1): Summary of IEEE Std 399-1997 Buses [18]

Bus#	Voltage Level (kV)	Name	Description	Connected Under DS69-1 or 69-2
1	69	69-1	Distribution SS	N/A
2	69	69-2	Distribution SS	N/A
3	13.8	MILL-1	Mill Bus	1
4	13.8	MILL-2	Mill Bus	2
5	13.8	FDR F	Primary Feeder	1
6	13.8	FDR H	Primary Feeder	1
8	13.8	FDR L	Primary Feeder	2
9	13.8	FDR E	Primary Feeder	1
10	13.8	EMERG	Emergency Bus	1
11	2.4	T4 SEC	Customer Bus	1
12	13.8	T5 PRI	Sub-Feeder	2
13	13.8	T6 PRI	Sub-Feeder	2
15	13.8	FDR I	Primary Feeder	2
16	13.8	T9 PRI	Primary Feeder	2
17	0.48	T5 SEC	Customer Bus	1
18	0.48	T6 SEC	Customer Bus	2
19	2.4	T7 SEC	Customer Bus	1
20	2.4	T8 SEC	Customer Bus	2
21	0.48	T9 SEC	Customer Bus	2
22	0.48	T5 MCC	Customer Bus	1
23	0.48	T6 MCC	Customer Bus	2
24	13.8	FDR M	Primary Feeder	2
25	13.8	T10 PRI	Sub-Feeder	1
26	13.8	FDR G	Feeder	1
27	13.8	T12 PRI	Primary Feeder	2
28	0.48	T10 SEC	Customer Bus	1
29	0.48	T11 SEC	Customer Bus	1
30	0.48	T12 SEC	Customer Bus	2
31	13.8	FDR P	Feeder	2
32	13.8	FDRQ	Feeder	2
33	0.48	T10 MCC	Customer Bus	1
34	0.48	T11 MCC	Customer Bus	1
35	0.48	T12 MCC	Customer Bus	2
36	2.4	T13 SEC	Customer Bus	2
37	0.48	T14 SEC	Customer Bus	2
38	0.48	480 TIE	480 Tie Bus	1
39	4.16	T3 SEC	Customer Bus	1
40	0.48	RECT	Customer Bus	1
50	13.8	GEN 1	Connected to Gen	1
51	0.48	AUX	Customer Bus	1
100	69	UTIL-1	Utility Source	N/A

Table (4-2): Summary of IEEE Std 399-1997 Transformers and Transmission Lines Data

Transformer Data											
From Bus	To Bus	Circuit	Per Unit Data(10 MVA Base)			Transformer Identifier	Transformer KVA	%Z	X/R	kV Ratio	Tap (kV)
			Resistance	Reactance	Susceptance						
1	3	1	0.00313	0.05324	0.0	T-1	15000	8.00	17.00	69 /13.8	69
2	4	1	0.00313	0.05324	0.0	T-2	15000	8.00	17.00	69 /13.8	69
5	39	1	0.04314	0.34514	0.0	T-3	1725	6.00	8.00	13.8/4.16	13.8
6	11	1	0.05575	0.36240	0.0	T-4	1500	5.50	6.50	13.8/2.4	13.8
12	17	1	0.06843	0.44477	0.0	T-5	1500	6.75	6.50	13.8/0.48	13.8
13	18	1	0.05829	0.37888	0.0	T-6	1500	5.75	6.50	13.8/0.48	13.8
6	19	1	0.01218	0.14616	0.0	T-7	3750	5.50	12.00	13.8/2.4	13.8
15	20	1	0.01218	0.14616	0.0	T-8	3750	5.50	12.00	13.8/2.4	13.8
16	21	1	0.15036	0.75178	0.0	T-9	750	5.75	5.00	13.8/0.48	13.8
25	28	1	0.05829	0.37888	0.0	T-10	1500	5.75	6.50	13.8/0.48	13.8
26	29	1	0.05829	0.37888	0.0	T-11	1500	5.75	6.50	13.8/0.48	13.8
27	30	1	0.05829	0.37888	0.0	T-12	1500	5.75	6.50	13.8/0.48	13.8
31	36	1	0.02289	0.22886	0.0	T-13	2500	5.75	10.00	13.8/2.4	13.8
32	37	1	0.10286	0.56573	0.0	T-14	1000	5.75	5.50	13.8/0.48	13.8
5	49	1	0.05918	0.35510	0.0	T-17	1250	4.50	6.00	13.8/0.48	13.8
50	51	1	0.06391	0.37797	0.0	T-18	1500	5.75	5.91	13.8/0.48	13.8

Transmission Line Data												
From Bus	To Bus	Circuit	Per Unit Data(10 MVA Base)			Conductors/Phase and Size	Length (ft)	Length (m)	kV	Rating (MVA)	Rating (A)	kV
			Resistance	Reactance	Susceptance							
100	1	1	0.00139	0.00296	0.00480	1-266.8 kcmil	10000	3048	69	55		
100	2	2	0.00139	0.00296	0.00480	1-266.8 kcmil	10000	3048	69	55		

Busway Data												
From Bus	To Bus	Circuit	Per Unit Data (10 MVA Base)			Material	Length (ft)	Length (m)	R (W/100ft)	X (W/100ft)	Rating (A)	kV
			Resistance	Reactance	Susceptance							
28	41	1	0.03429	0.02094	0.0	Cu	50	15.2	0.00158	0.000965	1000	0.48

Table (4-3): Summary of IEEE Std 399-1997 Generators and Cables Data [48]

Generator Data						
Bus Number	Unit ID	Real Power (MW)	Reactive Power Upper Limit (MVAR)	Reactive Power Lower Limit (MVAR)	Scheduled Voltage (pu)	
100	1	2.0	99.0	-99.0	1.0	
4	1	8.0	8.0	-2.0	1.0	
50	1	11.0	8.0	-2.0	1.0	

CABLE DATA												
From Bus	To Bus	Circuit	Per Unit Data			Cables/Phase and Size	Material	Length (ft)	Length (m)	kV	Rating (MVA)	Rating (Amps)
			Resistance	Reactance	Susceptance							
3	9	1	0.00150	0.00125	0.0	1-3/C-250kcmil CU	PVC	650	198.1	13.8	7.529	315
9	25	1	0.00424	0.00353	0.0	1-3/C-250kcmil CU	PVC	1833	558.7	13.8	7.529	315
9	13	1	0.00017	0.00014	0.0	1-3/C-250kcmil CU	PVC	75	22.9	13.8	7.529	315
9	12	1	0.00038	0.00032	0.0	1-3/C-250kcmil CU	PVC	165	50.3	13.8	7.529	315
3	5	1	0.00075	0.00063	0.0	1-3/C-250kcmil CU	PVC	325	99.1	13.8	7.529	315
3	26	1	0.00157	0.00131	0.0	1-3/C-250kcmil CU	PVC	680	207.3	13.8	7.529	315
3	6	1	0.00109	0.00091	0.0	1-3/C-250kcmil CU	PVC	471	143.6	13.8	7.529	315
4	15	1	0.00227	0.00189	0.0	1-3/C-250kcmil CU	PVC	980	298.7	13.8	7.529	315
4	7	1	0.00000	0.00010	0.0	breaker				13.8	7.529	315
7	27	1	0.00143	0.00119	0.0	1-3/C-250kcmil CU	PVC	619	188.7	13.8	7.529	315
7	16	1	0.00275	0.00229	0.0	1-3/C-250kcmil CU	PVC	1187	361.8	13.8	7.529	315
10	13	1	0.00046	0.00039	0.0	1-3/C-250kcmil CU	PVC	200	61.0	13.8	7.529	315
10	12	1	0.00002	0.00002	0.0	1-3/C-250kcmil CU	Steel	10	3.0	13.8	7.529	315
10	27	1	0.00110	0.00091	0.0	1-3/C-250kcmil CU	PVC	475	144.8	13.8	7.529	315
4	8	1	0.00076	0.00092	0.0	1-3/C-400kcmil CU	PVC	510	155.4	13.8	9.919	415
4	24	1	0.00118	0.00098	0.0	1-3/C-250kcmil CU	PVC	510	155.4	13.8	7.529	315
24	31	1	0.00079	0.00065	0.0	1-3/C-250kcmil CU	PVC	340	103.6	13.8	7.529	315
24	32	1	0.00112	0.00093	0.0	1-3/C-250kcmil CU	PVC	485	147.8	13.8	7.529	315
28	38	1	0.03039	0.02929	0.0	2-3/C-400kcmil CU	PVC	50	15.2	0.48	0.445	535
33	28	1	0.03813	0.02450	0.0	1-3/C-250kcmil CU	PVC	20	6.1	0.48	0.212	255
29	38	1	0.04012	0.03866	0.0	2-3/C-400kcmil CU	PVC	66	20.1	0.48	0.445	535
34	29	1	0.03813	0.02450	0.0	1-3/C-250kcmil CU	PVC	20	6.1	0.48	0.212	255
38	30	1	0.06079	0.05858	0.0	1-3/C-400kcmil CU	PVC	50	15.2	0.48	0.278	335
35	30	1	0.03813	0.02450	0.0	1-3/C-250kcmil CU	PVC	20	6.1	0.48	0.212	255
22	17	1	0.03813	0.02450	0.0	1-3/C-250kcmil CU	PVC	20	6.1	0.48	0.212	255
23	18	1	0.03813	0.02450	0.0	1-3/C-250kcmil CU	PVC	20	6.1	0.48	0.212	255
50	3	1	0.00122	0.00243	0.0	2-1/C-500kcmil CU	PVC	2000	609.6	13.8	18.350	768

Table (4-4): Matrix components ordering in relevance to IEEE Std 399-1997

Bus#	Bus Number by IEEE 399-1997	Voltage Level (kV)
1	50	13.8
2	100	69
3	51	0.48
4	1	69
5	2	69
6	3	13.8
7	4	13.8
8	9	13.8
9	10	13.8
10	5	13.8
11	6	13.8
12	15	13.8
13	24	13.8
14	12	13.8
15	26	13.8
16	8	13.8
17	25	13.8
18	40	0.48
19	39	4.16
20	11	2.4
21	19	2.4
22	17	0.48
23	20	2.4
24	27	13.8
25	16	13.8
26	31	13.8
27	32	13.8
28	13	13.8
29	21	0.48
30	36	2.4
31	37	0.48
32	28	0.48
33	18	0.48
34	29	0.48
35	30	0.48
36	33	0.48
37	23	0.48
38	22	0.48
39	34	0.48
40	20	2.4

4.6. Harmonics Monitors Allocation for IEEE Std 399-1997

From the data given in the previous section, one can observe that the load types will affect the allocation process. In other words, the percentage of non-linear loads in the system can affect the number of monitors that have to be installed. Thus, two allocations have been presented. The first case is assuming that all load buses are unknown or non-linear, and the second case is that all load buses are known or linear. However, in practice, it will be somewhere between the two cases. Figure (4.12) shows the allocation for Case 1, while Figure (4.13) presents the monitor allocation for Case 2.

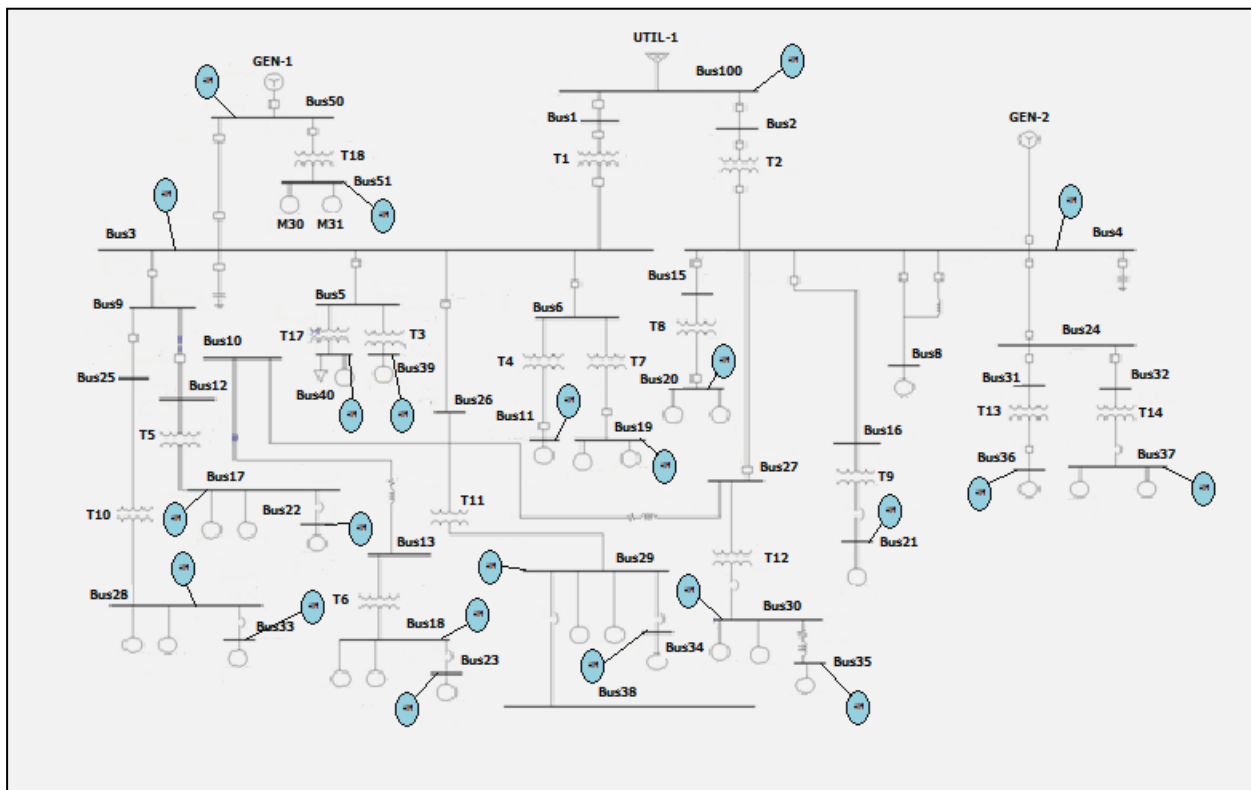

Figure (4.12): Harmonics Monitor Allocation for IEEE Std 399-1997 using VC method, Case 1

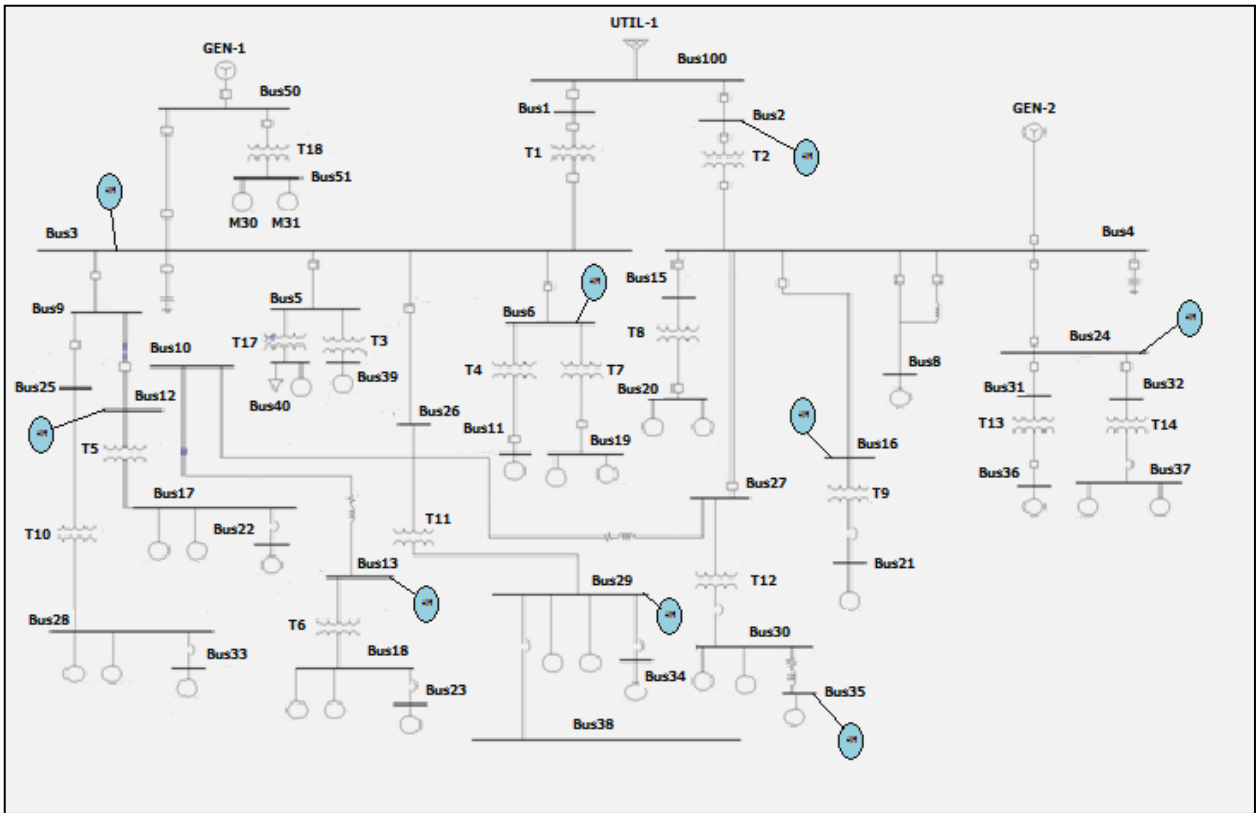

Figure (4.13): Harmonics Monitors Allocation of IEEE Std 399-1997 using VC method Case2

The reduction in the total cost for Case 1 is equal to 36%, and the number of monitors used is 23. The DRF in the first case is equal to 1.723. However, in Case 2, the reduction in the monitoring system cost equals 77%, and the number of monitors used is only 9. The data redundancy factor equals 1.437.

It is clear that the percentage of non-linear loads in the system affects the cost of the monitoring system, number of monitors, and the data redundancy of the monitoring system. The example of the IEEE 40-Bus shows only the two extreme situations for the distribution system, 100% nonlinear and 100% linear, where in practice, the percentage of nonlinear loads is somewhere between these two values, depending on the nature of the distribution system. Thus, a survey on different combinations of linear and nonlinear loads will be looked at in the next chapter.

4.7. Chapter Assessment

Electrical power organizations set standards to limit harmonics pollution in their distribution systems, and an incentive-based regulation has been proposed to force customers and utilities to follow these standards. If any customer or utility exceeds the standards' limits, they must pay a fee related to their harmonics pollution levels. To apply the incentive regulation properly, accurate identification of harmonics pollution sources is necessary. In order to get accurate identification, the bus voltages and the line currents in the entire system have to be known. This can be achieved by monitoring the distribution system.

The number of monitors needed and the cost of the monitors themselves increase the cost of the monitoring system; therefore, the monitors have to be installed in an optimum way that decreases the number of monitors needed and the cost of the monitors. The cost of the monitors varies from one location to another, depending on the number of current transducers and DAQs required. So, the monitors should be installed in strategic locations that reduce the monitors' number and cost due to the decreasing of transducers and DAQs used. Several optimization techniques have been applied to monitor allocation problems; however, the purpose of the monitoring system, such as characterizing system performance, characterizing specific problems, or enhancing power quality services, plays the main role in choosing the proper optimization techniques for the allocation problem.

The vertex-colouring (VC) method has been applied for the harmonics pollution monitoring allocation problem in order to measure or calculate all the bus voltages and line currents of the system under monitoring. Each bus in the system is represented by a vertex, and each line is represented by an edge in the VC. The optimum solution using the VC method is when all buses and lines have been coloured at minimum monitoring system cost. This can be achieved by minimizing the number of monitors used and minimizing the cost of the monitors themselves. The VC method is applied to different-sized systems, and the fundamental advantage of the VC method is the low input data required: only the existence matrix. In addition, the monitors' number and cost and the data redundancy factor shows better results using VC compared to the results of the packing and covering method.

In order to identify the sources of harmonics pollution in the distribution system, the customers' buses and loads should be monitored. If the bus under monitoring was a known bus, different loads' currents can be calculated easily using basic circuit analysis rules; however, if the customer's bus was an unknown bus, the loads connected to that bus should be measured, because the basic circuit rules cannot be applied for nonlinear loads. As a result, the percentage of nonlinear loads in the distribution system affects the cost of the harmonics pollution monitoring system used to identify the sources of harmonics in the system. Thus, different combinations of loads in the IEEE 40-Bus will be discuss in detail in Chapter Five before illustration of the methods of identifying the harmonics-producing devices in the system.

Chapter 5

Harmonics Pollution Sources Identification

5.1. Introduction

The impacts of harmonic voltage and current on distribution electrical equipment are highlighted in Chapter 3; however, their consequences have also been explained in great detail in many publications [26–28]. The currents injected by nonlinear devices can degrade the voltage waveforms in the distribution power system, which causes misoperation or damage to the customers' equipment. Moreover, harmonics current flow in the distribution network causes electrical losses. These losses are small compared to the fundamental losses due to the small magnitude of the harmonics currents; however, because of their continuity in the system, the cost of these losses is tangible. Indeed, the increase in use of electronic power devices and the augmented use of sensitive equipment in the distribution system can make the consequences of the harmonics pollution significantly costly [29]. For instance, according to Barry Kennedy in his book "*Power Quality Primer*", there is a case study of a building with 240 dispersed computers and other electronic equipment working 4,380 hours per year with a load of 60 kW; the harmonics flow in the system increased losses by 4802 W at a cost of \$2,101 per year (based on a cost of energy of \$0.10/kWh) [15].

The cost of harmonics pollution consequences and the harmonics pollution mitigation costs should be regained. One way of getting these back is increasing the price of electricity in order to cover all additional costs; however, the main drawbacks are, first, that increasing the price of electricity will affect the electric companies' profits under deregulation systems, and second, it would force innocent customers (non-harmonics-producing customers) to pay an extra fee not related to their own usage [16]. As mentioned before, an incentive scheme should be considered as a solution for controlling harmonics pollution in the distribution systems. Thus, the identification of harmonics pollution sources is the first step toward controlling and solving the problem. The dynamic nature of the distribution system and the difference in features from one distribution network to another, such as the voltage level, load density, and the supplied customers' types – residential, commercial or industrial – makes the identification process a hard task. The harmonics currents produced by different types of customers have distinct

characteristics. Hence, the identification method has to be valid for different types of harmonics pollution.

Not only does the quality of the harmonics-producing devices affect the identification process, but also, quantity has a crucial impact. As mentioned in the previous chapter, the high number of nonlinear devices in a distribution system increases the number of monitors that have to be installed in order to cover the entire system. As a result, the amount of data that has to be analysed is large and sometimes overlapping, which makes the identification process harder. The identification method has to find out accurately the source(s) of harmonics pollution in the distribution system using measurement data obtained from the monitoring system.

This chapter is intended to cover the process of identification of harmonics pollution sources. Section 5.2 will discuss different types of harmonics source models. An investigation on the rate of pollution in the distribution system has been highlighted in section 5.3, while section 5.4 presents the methodology for identifying the harmonics pollution source(s) and shows several case studies for the proposed method. Finally, the chapter's assessments are discussed in section 5.5.

5.2. Harmonics Source Models

For most conventional studies, the power system is basically modeled as a linear system with passive elements excited by constant magnitude and constant frequency sinusoidal voltage sources. However, with the widespread growth of power electronics loads nowadays, significant amounts of harmonic currents are being injected into power systems. Harmonic currents not only disturb loads that are sensitive to waveform distortion, but also cause many undesirable effects on power system components [20]. When a sinusoidal voltage is applied to a certain type of load, the current drawn by the load is proportional to the voltage and impedance, and the current follows the voltage waveform. These loads are classified into linear loads and nonlinear loads. In the case of linear loads, the voltage and current follow one another without any distortion to their pure sine waves; examples of linear loads are resistive heaters, incandescent lamps, and constant speed induction and synchronous motors.

In contrast, nonlinear loads cause the current to vary disproportionately with the voltage during each half cycle. In nonlinear loads, the current and voltage have waveforms that are non-pure sinusoidal, containing distortions, whereby the 60-Hz waveform has numerous additional waveforms placed upon it, creating multiple frequencies within the normal 60-Hz sine wave. The

multiple frequencies are harmonics of the fundamental frequency. Nonlinear loads are simply any piece of equipment or appliance that changes its consumption of electricity over time in a nonlinear fashion. With nonlinear loads the current and voltage do not follow each other linearly. Nonlinear loads can be categorized into two types: magnetic devices and power electronics switching devices.

5.2.1. Nonlinear magnetic devices

This category includes arc furnaces, arc welders, the iron cores of transformers, and discharge-type lighting (fluorescent, sodium vapour, and mercury vapour) with magnetic instead of electronic ballasts. As nonlinear currents flow through a facility's electrical system and distribution-transmission lines, additional voltage distortions are produced due to the impedance associated with the electrical network [16]. Fluorescent lights, as an example of this category, are discharge lamps; thus, they require a ballast to provide a high initial voltage to initiate electric current flow in the fluorescent tube. Once the discharge is established, the voltage decreases as the arc current increases. It is essentially a short circuit between the two electrodes, and the ballast has to quickly reduce the current to maintain the specified lumen output. Thus, ballast is also a current-limiting device in lighting applications. Figure 5.1 illustrates a typical current waveform of a fluorescent lamp with magnetic ballast and its harmonics spectrum; however, figure 5.2 shows the typical current waveform of a transformer's iron core and its harmonics spectrum.

5.2.2. Nonlinear switching devices

Converters and power electronic devices are switching elements that control the current by semiconductor switch operations. This category constitutes most of the nonlinear loads in power systems, starting from single phase diode bridge rectifiers up to HVDC converters. This category can be classified into single-phase and three-phase devices [16].

a. Single-phase switching devices

Single phase Diode Bridge Rectifiers (DBR), Switch Mode Power Supplies (SMPS), and Phase Angle voltage controllers (PAVC) are examples of devices of this type. These devices are the most popular choice for low-power applications. Most of these devices are utilized in residential and commercial loads, such as computers and digital TVs; however, DBRs and PAVCs can be utilized in some small industries to supply small adjustable-speed drivers (ASDs)

or single-phase induction motors. The typical current spectrum and waveform of a typical ASD has been shown in figure 5.3.

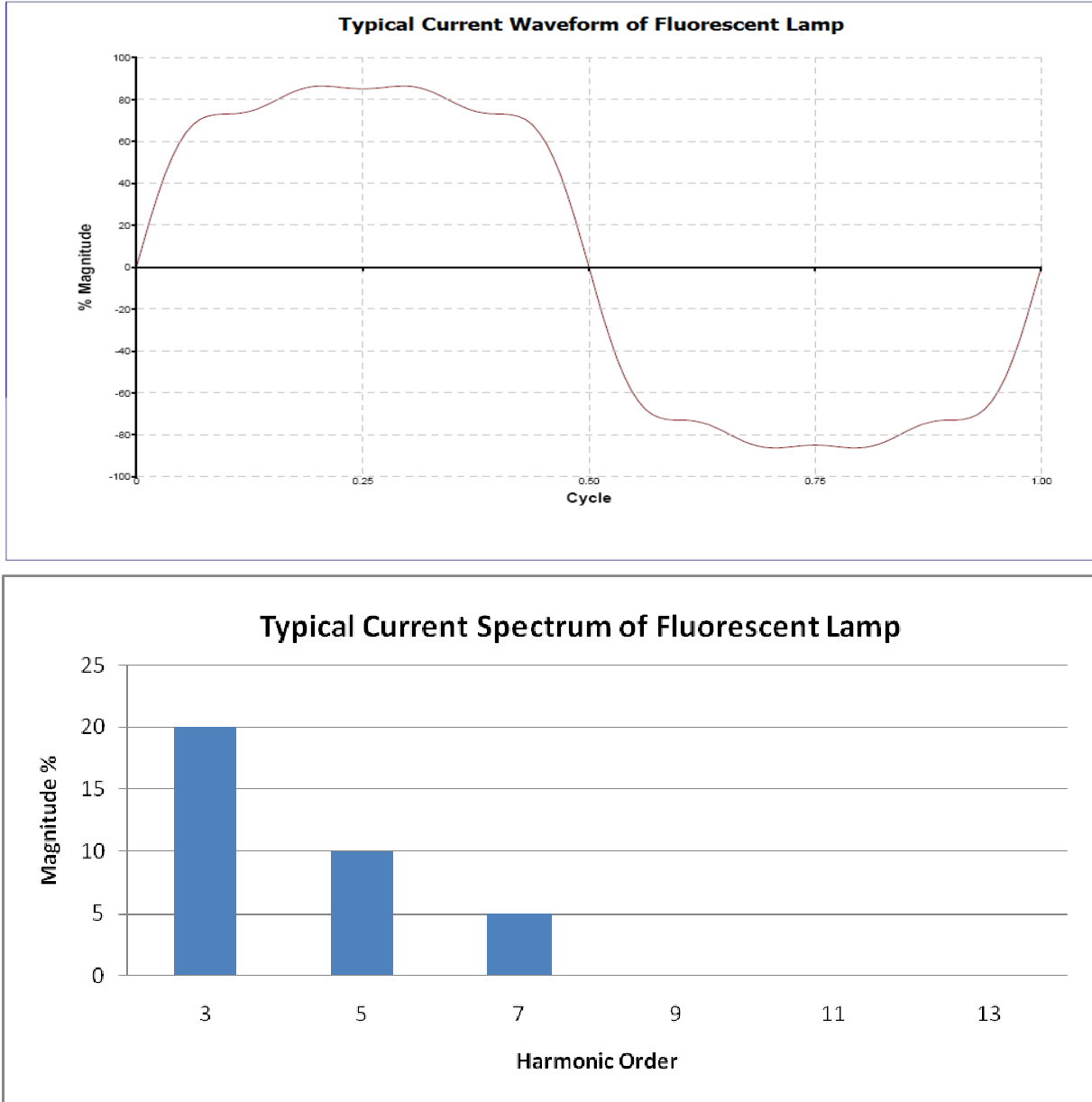

Figure (5.1): Typical current waveform and spectrum of Fluorescent lamp

b. Three-phase switching devices

Three-phase rectifiers, Variable-Frequency drives (VFD), and typical IEEE 6 and 12 pulse converters are example of this category. Pulse Width Modulation (PWM) is used

in these converters for controlling the output voltage. The ratio between the switching frequency F_S and fundamental frequency F_1 determines the configuration of the converters. For instance, if (F_S/F_1) equals 6, then the converters are 6-pulse converters. Typical current waveforms and spectrums of an IEEE 6-pulse charger and an IEEE 12-pulse converter are shown in Figure 5.4 and 5.5, respectively.

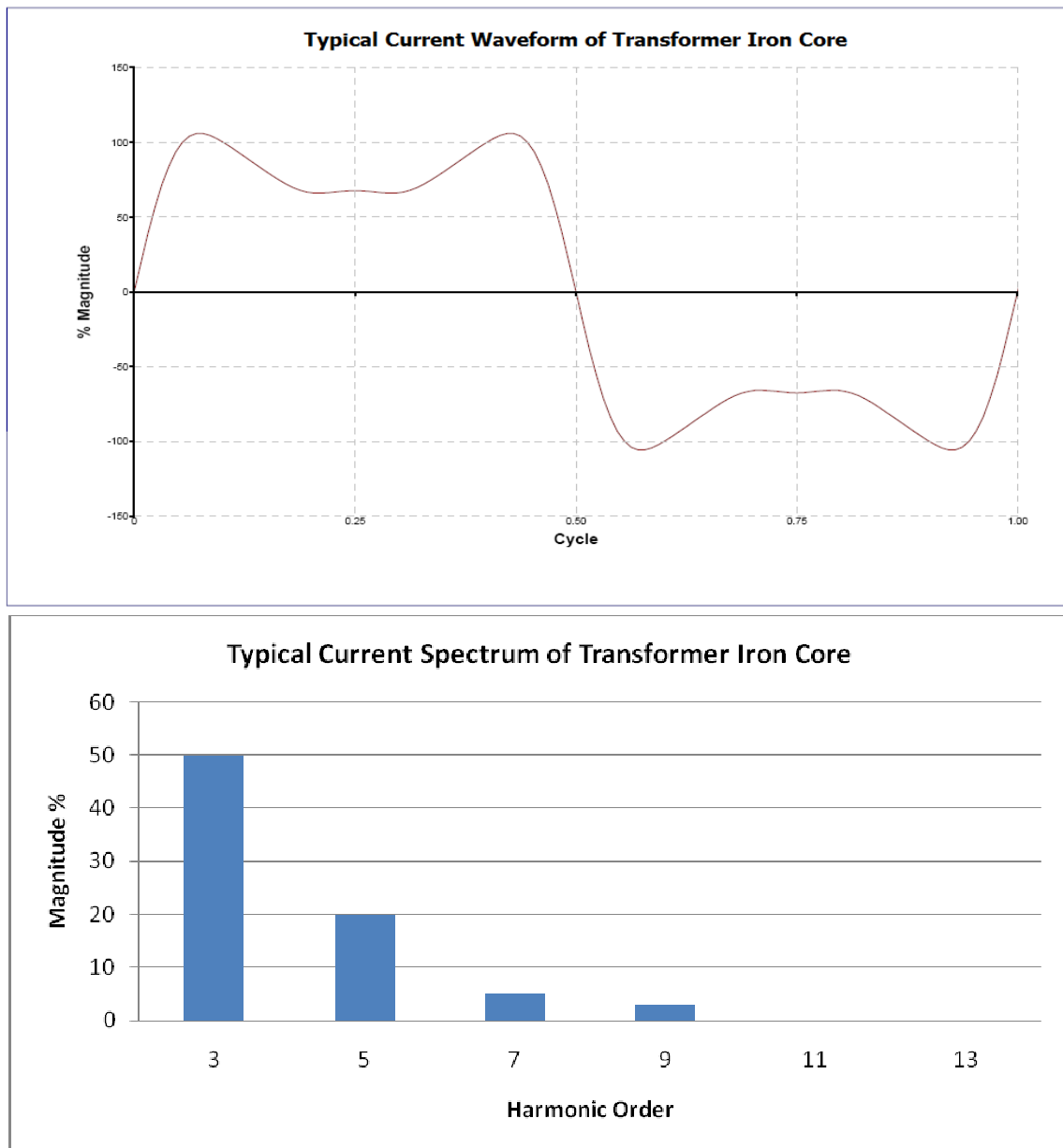

Figure (5.2): Typical current waveform and spectrum of Transformer Iron Core

However, figures 5.6 and 5.7 show typical the current waveform and spectrum of 12- and 18-pulse VFDs. Most three-phase switching devices are utilized in the industrial part of the distribution system, and three-phase devices usually have a higher rated power. Thus, switching devices used in three-phase applications should not have low-order harmonic currents due to the large magnitude of the fundamental current. In other words, when the rated power of equipment is high, the low-order harmonics should be eliminated to keep both the amount of harmonic currents produced and THD_V within limits.

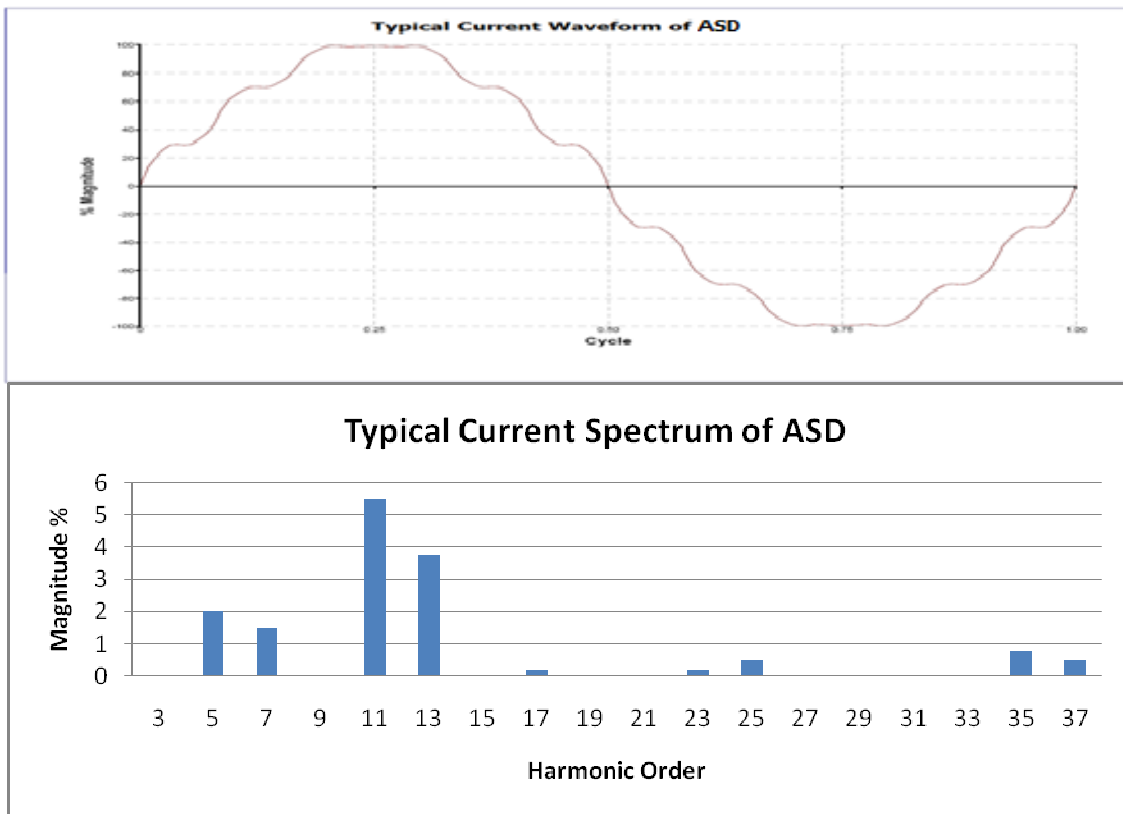

Figure (5.3): Typical current waveform and spectrum of ASD

Typical distribution systems have combinations of these devices in their networks. The load density and customer types – residential, commercial, and industrial – can vary the percentage of non-linear loads in the distribution system. Therefore, the influences of different percentages of nonlinear loads in the distribution system have to be investigated. In the next section, different combinations of linear and nonlinear loads are simulated using the ETAP 7.1 simulator package.

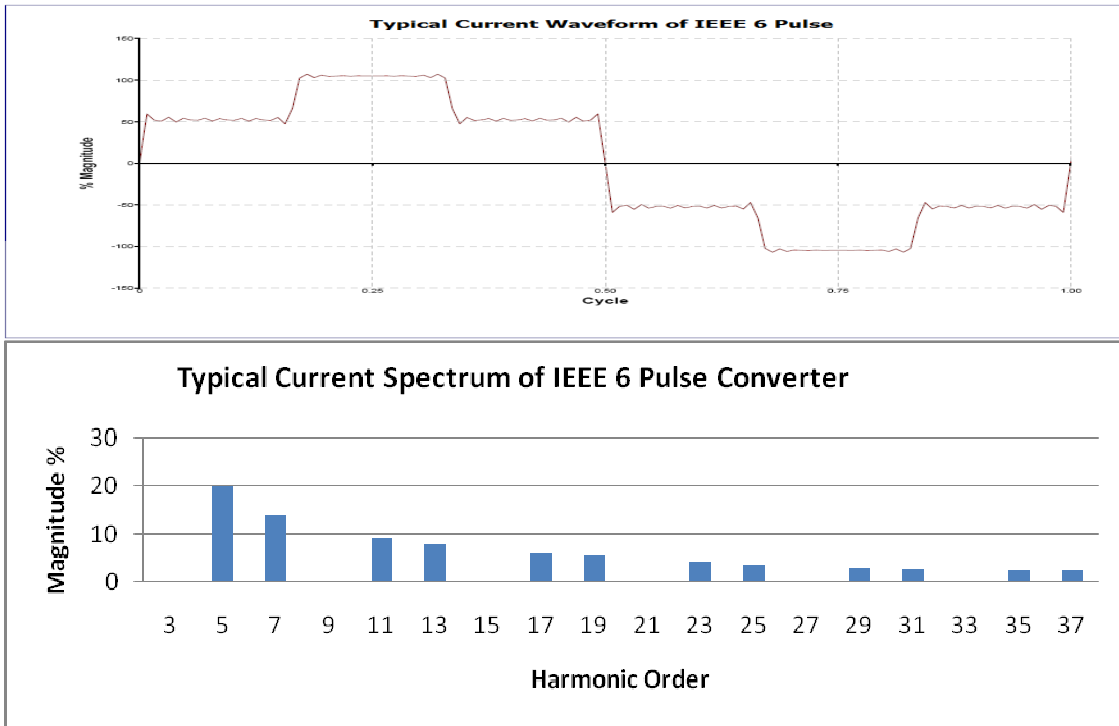

Figure (5.4): Typical current waveform and spectrum of IEEE 6 Pulse converter

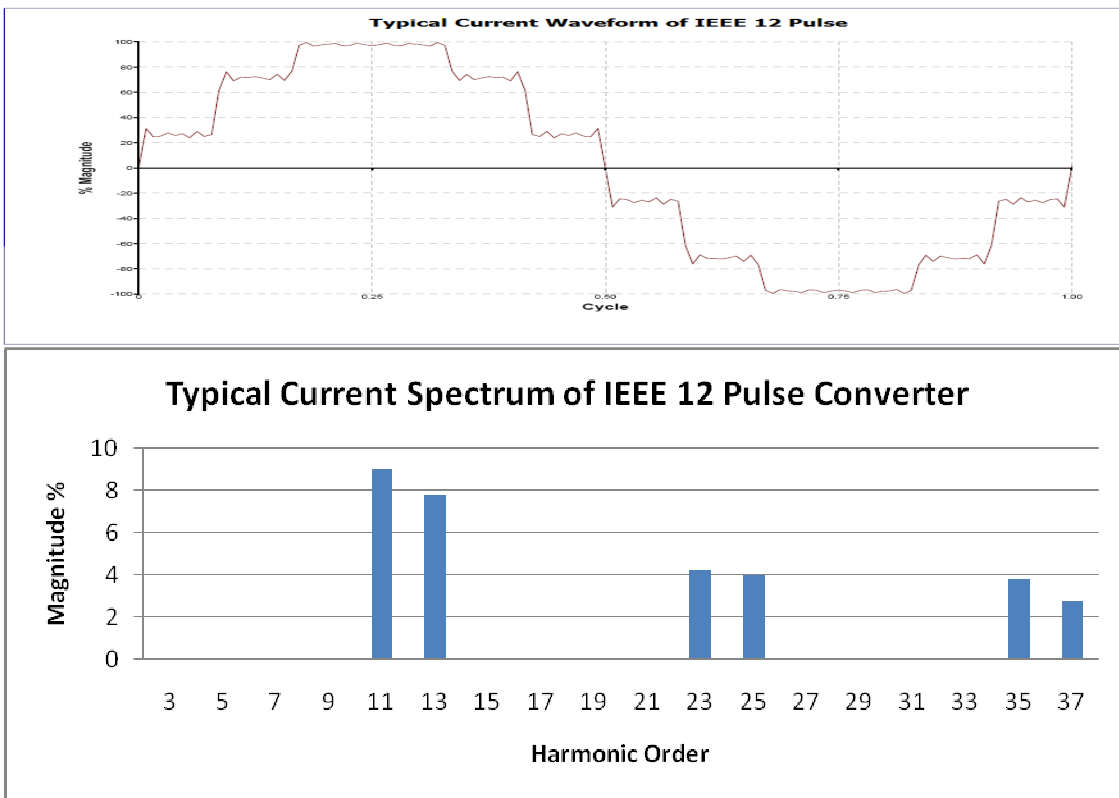

Figure (5.5): Typical current waveform and spectrum of IEEE 12 Pulse converter

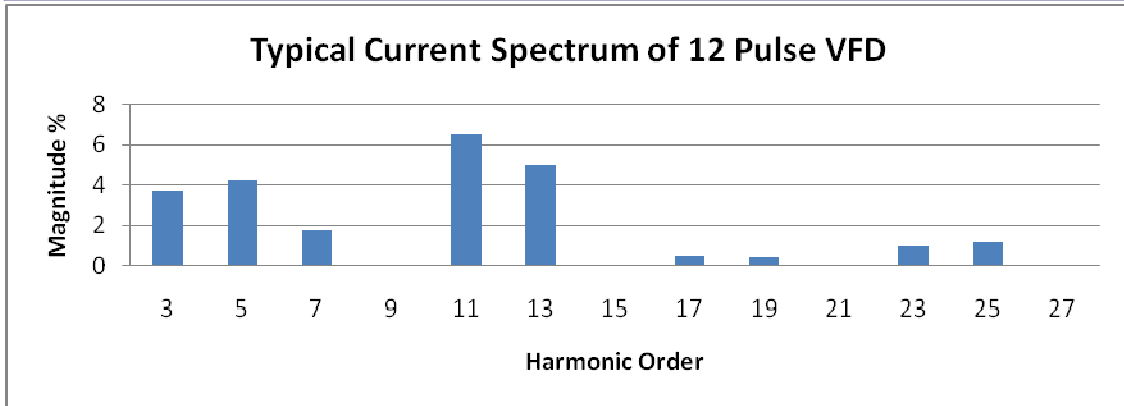
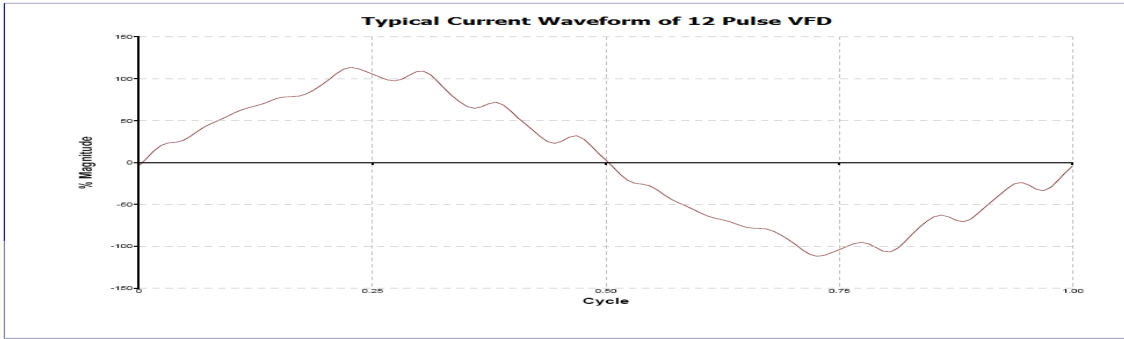

Figure (5.6): Typical current waveform and spectrum of 12 Pulse VFD

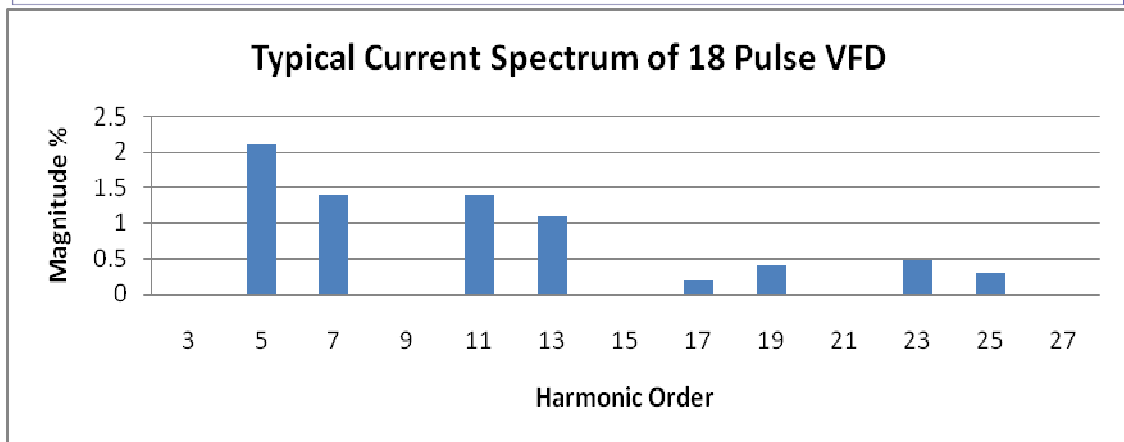
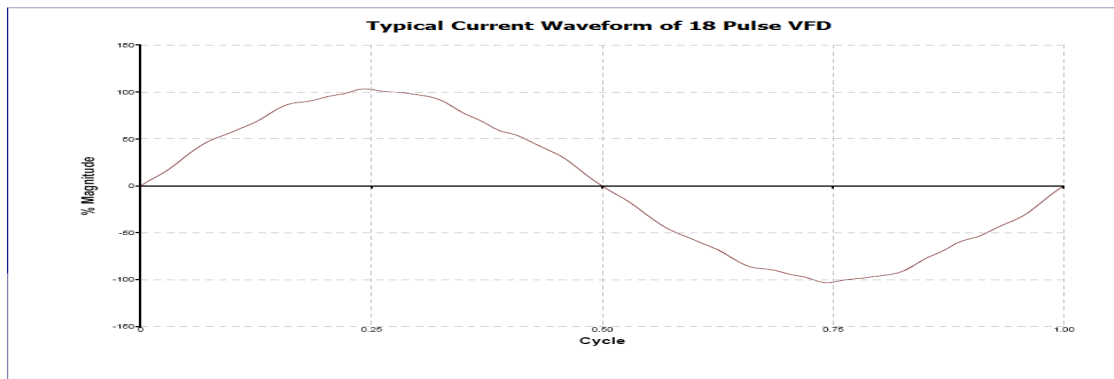

Figure (5.7): Typical current waveform and spectrum of 18 Pulse VFD

5.3. Investigation of Polluted Distribution System

The composition of loads in a distribution system varies from one network to another; the composition variation has a crucial impact on the harmonics pollution in the network. For example, a distribution system supplying a network that has a composition of 40% industrial, 30% commercial, and 30% residential will probably have a higher harmonics pollution level than a network having a combination of 80% residential and 20% commercial. Consumers' loads play a very important role in network harmonic characteristics. Consumers' loads can be divided basically into two sorts: linear and nonlinear. Table 5.1 shows the basic equipment used in each area of the distribution system. However, the quantity of nonlinear equipment in the combination and the rate of the equipment being used are two factors causing increased probability of having a polluted network when the rates of industrial and commercial loads are increased [24].

Table (5-1): Load composition in typical distribution networks

Nature	Type of Load	Electrical Characteristics
Residential	Incandescent Lamp Compact Appliances Small Motors Computers Home Electronics	Linear (passive resistive) Nonlinear Nonlinear Nonlinear ..
Residential and Commercial	Refrigerator Washing Machine Air Conditioner	Linear – Passive resistive Linear –Passive inductive Linear –Passive resistive
Commercial	Incandescent Lamp Resistive Heater Fluorescent Lamp (Electronics) Computers ASDs Other electronics loads	Linear –Passive inductive Linear –Passive inductive Nonlinear Nonlinear Nonlinear ...
Small Industrial Plants (Low Voltage)	Fan Pump Compressor Resistive Heater Arc Furnace ASDs Other Electronics Loads	Linear –Passive inductive Linear –Passive inductive Linear –Passive inductive Linear –Passive resistive Nonlinear Nonlinear ...

In order to investigate the impact of different compositions of loads, harmonics-flow analysis has been applied for the IEEE Std. 399 -1997 system, Figure (5.8), using the ETAP 7.1 simulator package. Three different scenarios are considered in this study: a lightly polluted system, a medium polluted system, and a heavily polluted system. As mentioned in section 4.5, the system has three supply buses: a utility and two generator buses that supply 28 MVA (26.5 MW, 8.5 MVAR) loads, and there is no harmonics filter in the system. All buses are limited by IEEE 519-1995 standards; 5% of total voltage harmonics distortion (THD_V) and 3% of individual voltage harmonics distortion (IHD_V).

5.3.1. Lightly Polluted System

The distribution system can be assumed to be a lightly polluted system when the percentage of harmonics-producing loads is up to 12.5% of the total supplied load, so the amount of harmonic currents produced can be absorbed by the rest of the linear loads in the system. However, the harmonics-producing loads can be either distributed in the network or concentrated in one bus. Therefore, harmonics flow analysis is utilized for both cases to determine the network harmonics characteristics.

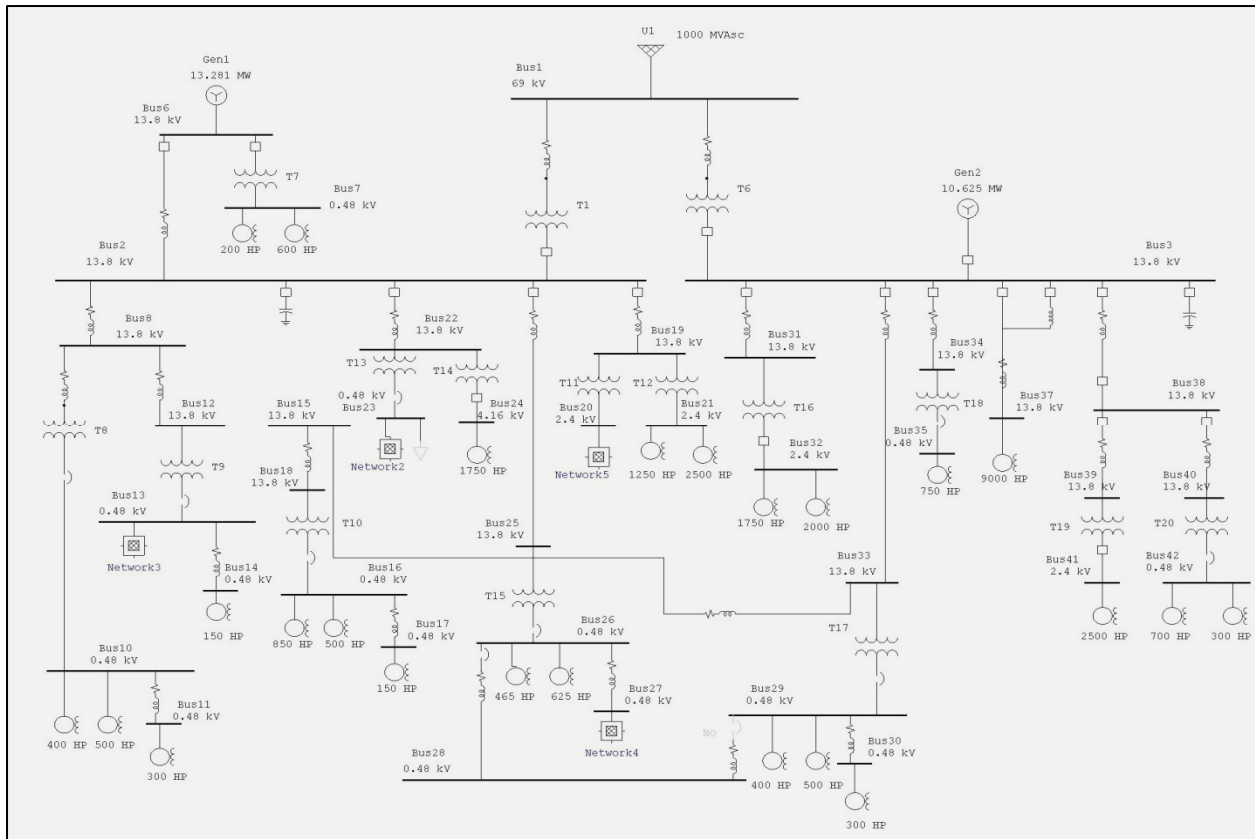

Figure (5.8): IEEE Std. 399 – 1997 system

a. Distributed Harmonics – producing Loads in lightly polluted systems

The harmonics-producing devices are randomly distributed in the system. Different types of nonlinear devices are taken into consideration. The total percentage of nonlinear loads to the overall system load is equal to 11.7%. Table 5.2 shows details about the distribution of light harmonics pollution-producing loads.

Table (5.2): Distribution of harmonics-producing loads in a lightly polluted system

Bus Number	Bus Voltage (kV)	Device Rating		Type of Nonlinear Device	Percentage to Total System Load
		P(MW)	Q(MVA)		
13	0.48	1.465	1.058	UPS 12-Pulse Converter	6.45%
20	2.4	0.444	0.169	18-Pulse VFD	1.7%
23	0.48	0.765	0.474	6-Pulse Charger	3.2%
27	0.48	0.111	0.044	12-Pulse VFD	0.43%

The simulation results show that the THD_V of buses 13, 14, and 23 have exceeded the standard limit. Both buses 13 and 23 have nonlinear loads connected, so their voltage

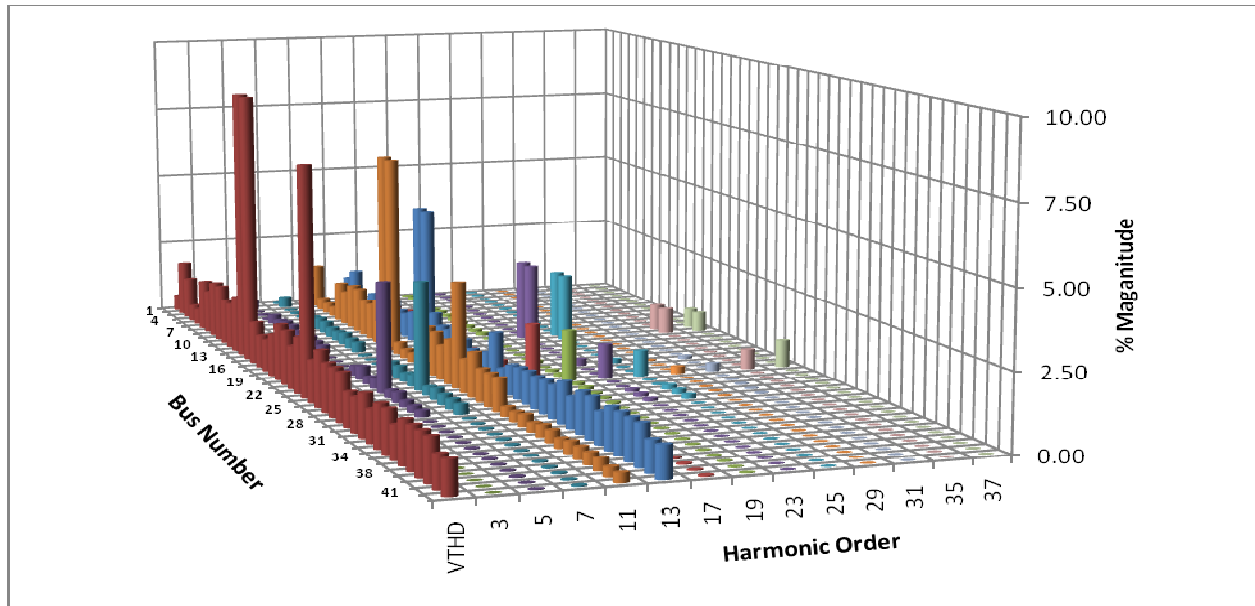

Figure (5.9): The harmonics spectrum of distribution harmonics-producing loads in a lightly polluted system

distortion limit has been exceeded, whereas Bus 14 has a linear load connected. Thus, Bus 14 has been polluted by the harmonic distortion produced from the system. If Bus 13 and Bus 14 share the same PCC, both buses have accounted for the produced harmonics pollution from the IEEE standard point of view; therefore, identifying the source of harmonics is a crucial need. Figure 5.9 shows the simulation results of this case.

b. Concentrated Harmonic-producing loads in lightly polluted systems

The scenario here is little bit different; rather than distributing the harmonic-producing loads over the entire system, the harmonic-producing loads are concentrated in one bus to investigate the load rating impact on the harmonics pollution of the system. Moreover, the analysis applies for different load types to illustrate the impact of the harmonic-producing device’s type on the harmonics pollution of the system. Table 5.3 presents the details of both cases.

Table (5.3): A concentrated harmonic-producing load in a lightly polluted system

Case	Bus Number	Bus Voltage (kV)	Device Rating		Type of Nonlinear Device	Percentage of Total System Load
			P(MW)	Q(MVA)		
1	21	2.4	2.550	1.580	12-Pulse Charger	10.7%
2	21	2.4	2.550	1.580	Large ASD	10.7%

According to the system configuration, Bus 21 is fed from Bus 2 through Bus19. The harmonics spectrum results from Case 1, Figure 5.10, shows that all buses – except the heavy loaded buses Bus 13, Bus 14, and Bus 24 – that are fed from the same bus that is feeding the harmonic-producing bus, Bus 21, have exceeded THD_V in that section. While the entire system buses have exceeded the IHD_V for harmonic orders 11th and 13th, and referring to Figure 5.8, the magnitudes of the 11th and 13th of the typical 12-Pulse converter are almost 8% of the fundamental currents; therefore, the harmonics currents produced from the 11th and 13th are considered as the main source of current distortion. In case 2, the type of non-linear device is changed. The new device has a better harmonic current spectrum, with individual harmonics limited to 5.5% (Figure 5.3). The result shows better performance in the THD_V , and only the near buses and lightly loaded buses are affected, whereas the IHD_V for the entire system’s buses

exceed the IEEE standard limit due to the 11th and 13th harmonics. Figure 5.11 presents a comparison between the two cases in the harmonics spectrum of THD_V, 11th HD_V, and 13th HD_V.

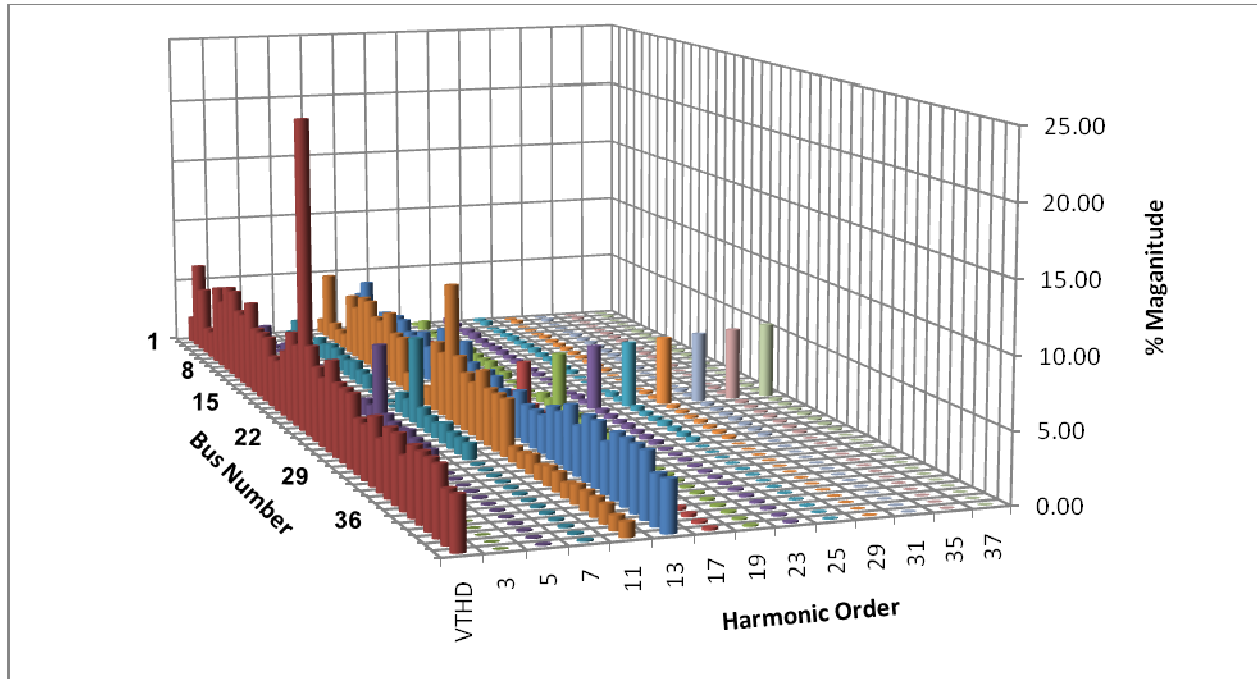

Figure (5.10): The harmonics spectrum of concentrated harmonics-producing load Case 1 in a lightly polluted system

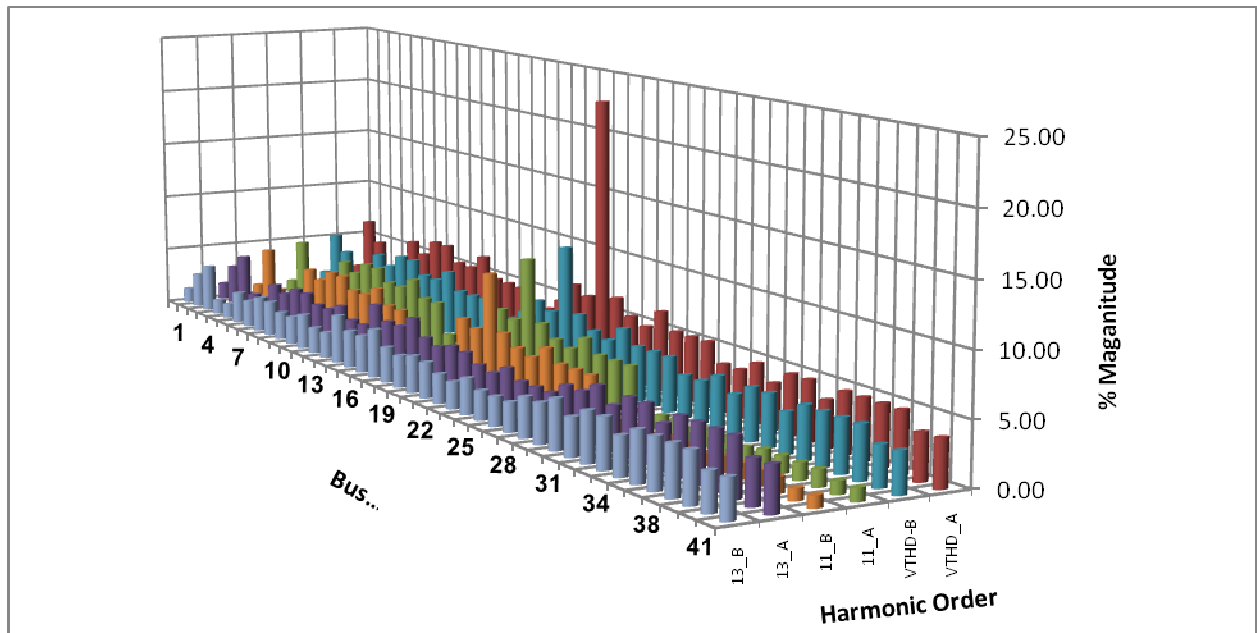

Figure (5.11): Comparison between Case 1 and Case 2 in harmonics spectrum of concentrated harmonics-producing loads in a lightly polluted system

5.3.2. Medium Polluted System

The distribution system can be assumed to be a medium polluted system if the percentage of nonlinear loads in the system is between 12.5% – 25%. Likely they can be distributed over the entire system; however, the concentrated nonlinear loads should be taken in the harmonics flow analysis in order to emphasize the impact of concentrated harmonic-producing loads in the distribution system.

a. Distributed Harmonics – producing Loads in medium polluted systems

Different types of nonlinear devices are randomly distributed in the system. The total percentage of nonlinear loads to the overall system loads is equal to 25%. Table 5.4 shows the details about the distribution of harmonics pollution-producing loads in a medium polluted system. The maximum individual harmonic-producing load’s percent does not exceed 5% of the total supplied loads, and the overall system size is equal to 28.2 MVA.

Table (5-4): Distribution of harmonic-producing loads in a medium polluted system

Bus Number	Bus Voltage (kV)	Device Rating		Type of Nonlinear Device	Percentage of Total System Load
		P(MW)	Q(MVA)		
7	0.48	0.666	0.413	UPS 12-Pulse Converter	2.79%
10	0.48	0.836	0.472	6-Pulse Charger	3.43%
14	0.48	0.146	0.058	18-Pulse VFD	0.56%
16	0.48	0.981	0.584	6-Pulse Charger	4.08%
20	2.4	0.444	0.169	12-Pulse VFD	1.7%
24	4.16	1.463	0.567	18-Pulse VFD	5.6%
27	0.48	0.111	0.044	12-Pulse VFD	0.43%
30	0.48	0.253	0.103	18-Pulse VFD	0.98%
35	0.48	0.622	0.467	UPS 12-Pulse Converter	2.78%
42	0.48	0.638	0.395	6-Pulse Charger	2.68%

The harmonics flow analysis results show that the type of nonlinear device affects the harmonics performance of the system. Both Bus 10 and Bus 16 have 6-pulse converters, and both of them exceed the THD_v limit and IHD_v limit. Indeed, their harmonics pollution infects the nearby buses, Bus 11 and Bus 17, by making them go over the limits. Nevertheless, Bus 42 has the same type of nonlinear devices, 6-pulse converters, but there is no influence on the nearby buses due to the higher voltage level that the nearby bus, Bus 41, has: 2.4 kV. On the other hand, Bus 14 and Bus 30 have better harmonics performance devices, 18-pulse VFDs, so they have operated within the limits, while Bus 24 has exceeded the IHD_v limit even when it has the same device due to its high power rate: 5.6%. Clearly, not only the type of nonlinear device affects the system's harmonics pollution, but also the power rate of the device has a great effect, too. Figure 5.12 illustrates the results of the harmonics flow analysis for the medium polluted system.

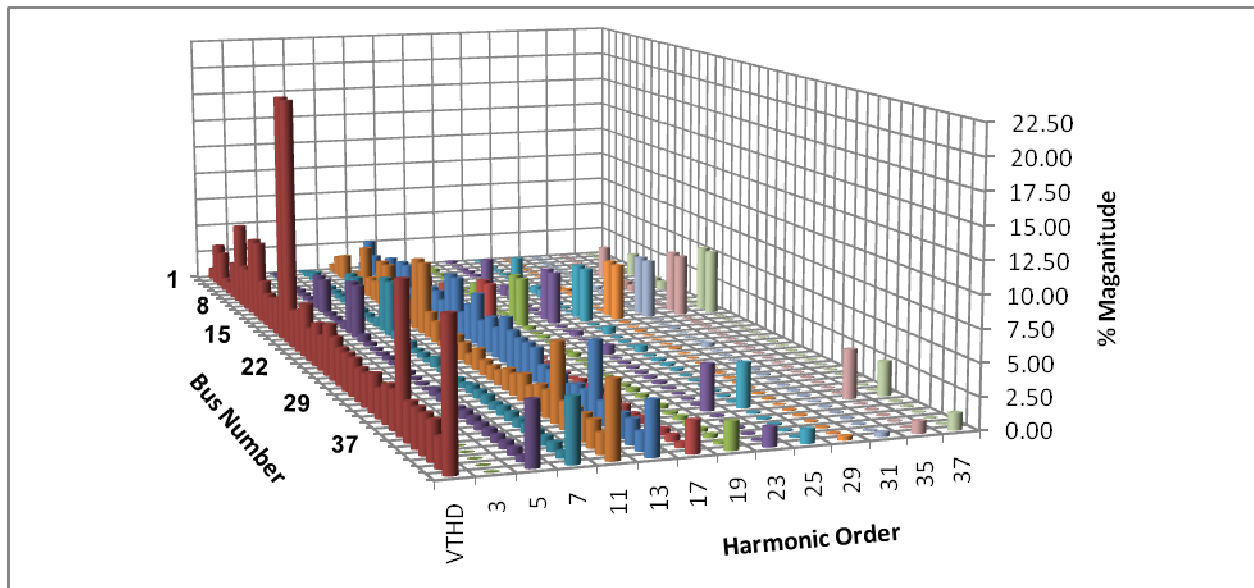

Figure (5.12): The harmonics spectrum of distribution harmonics-producing loads in a medium polluted system

b. Concentrated Harmonics – producing Loads in medium polluted systems

In this part, the total supplied load has been slightly increased; 30 MVA rather than 28.2MVA. The nonlinear load has been concentrated on Bus 37, with a percentage of 26%. 12-pulse VFD and 18-pulse VFD are used for Case 1 and Case 2, respectively. Table 5.5 highlights the system configuration of the concentrated harmonics-producing device in a medium polluted system. In Case 1, the entire system's buses have been polluted by Bus 37, and all buses exceed

the limits, THD_V and IHD_V . Both the 11th and the 13th harmonics account for the harmonics pollution in the system (Figure 5.13).

Table (5-5): Concentrated harmonic – producing load in the medium polluted system

Case	Bus Number	Bus Voltage (kV)	Device Rating		Type of Nonlinear Device	Percentage of Total System Load
			P(MW)	Q(MVA)		
1	37	13.8	7.41	3.131	12 Pulse VFD	26 %
2	37	13.8	7.41	3.131	18 Pulse VFD	26%

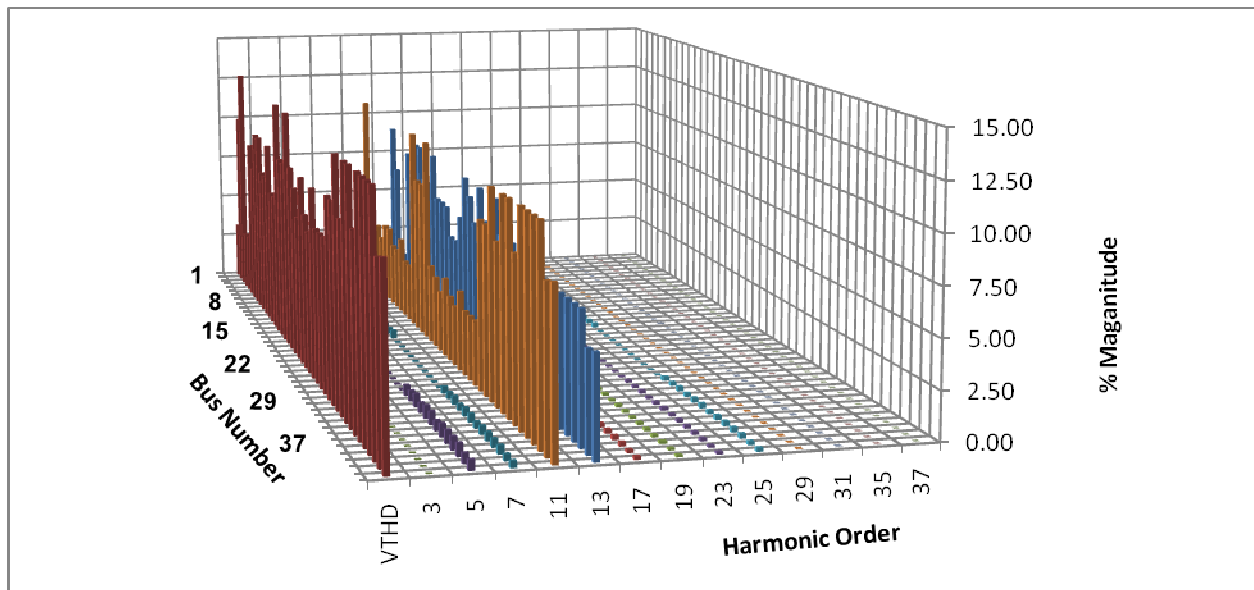

Figure (5.13): The harmonics spectrum of concentrated harmonics-producing load in a medium polluted system

The harmonic analysis is carried out again for the same system with an 18–pulse VFD as a harmonics-producing device. The results show a huge improvement of the harmonics pollution level. All system buses, including Bus 37, have been operating within the limits. Improving the type of nonlinear device enhances the system harmonics performance very significantly. According to figures 5.6 and 5.7, the harmonic currents are limited to 6.25% in the 12–pulse VFD, while the harmonic currents in the 18–pulse VFD are limited to 2%. When working at a high voltage level and high power rating, the harmonic currents of the nonlinear device should be very low in order to control the harmonics pollution level of the system. Figure 5.14 presents a

comparison between Case 1, with a 12-pulse VFD, and Case 2, with an 18-pulse VFD. The comparison covers THD_V, the 11th harmonic, and the 13th harmonic.

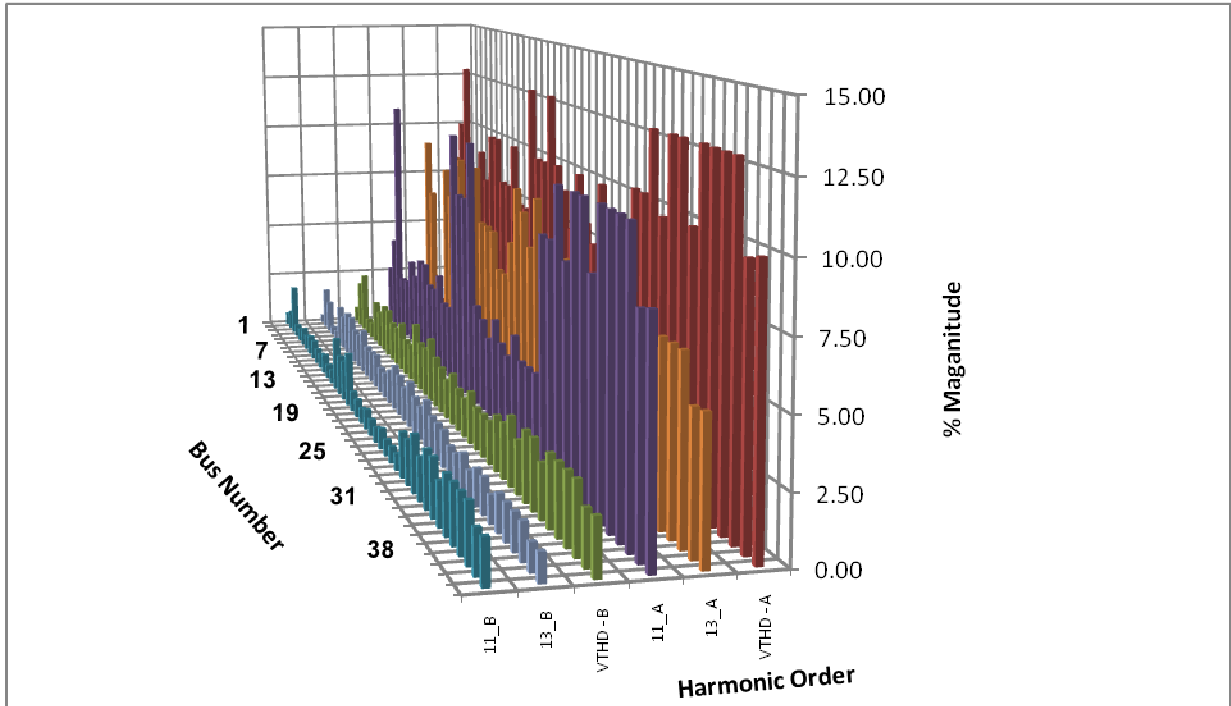

Figure (5.14): Comparison between Case 1 and Case 2 in harmonics spectrum of concentrated harmonics-producing load of a medium polluted system

5.3.3. Heavily Polluted System

The heavily polluted system can be assumed as any distribution system that has 25% – 40% nonlinear loads of its total load. Normally, industrial consumers have the majority of heavily polluted systems. Similar to lightly and medium polluted systems, heavily polluted systems can be formed either by distributing the harmonics-producing devices or by concentrating the harmonics-producing devices. Both scenarios are carried out, and the system total supplied load is 28 MVA.

a. Distributed harmonics-producing loads in heavily polluted systems

Different types of nonlinear devices are randomly distributed in the system. The total percentage of nonlinear loads to the overall system load is equal to 39.11%. Table 5.5 shows the details about the distribution of harmonics pollution-producing loads. The maximum individual harmonic-producing load percentage does not exceed 10% of the total supplied loads.

Table (5-6): Distribution of harmonic-producing loads in a heavily polluted system

Bus Number	Bus Voltage (kV)	Device Rating		Type of Nonlinear Device	Percentage to Total System Load
		P(MW)	Q(MVA)		
7	0.48	0.666	0.413	UPS 12-Pulse Converter	2.8%
10	0.48	0.836	0.472	6-Pulse Charger	3.4%
13	0.48	0.981	0.584	6-Pulse Charger	4%
16	0.48	0.981	0.584	12-Pulse Charger	4%
24	4.16	1.463	0.567	18-Pulse VFD	5.6%
26	0.48	0.797	0.476	UPS 12-Pulse Converter	3.3%
29	0.48	0.810	0.457	6-Pulse Converter	3.32%
35	0.48	0.476	0.295	12-Pulse VFD	2%
41	2.4	2.087	0.799	18-Pulse VFD	7.98%
42	0.48	0.638	0.395	6-Pulse Converter	2.68%

When the level of nonlinear loads comes to a heavily polluted level, the entire system's buses are polluted, and they exceed the THD_V and the IHD_V limits. It is rare to have a heavily polluted system in practice; however, if this is the case, a system harmonics performance study is essential. Figure 5.15 illustrates the results of the distribution of harmonics-producing loads in a heavily polluted system.

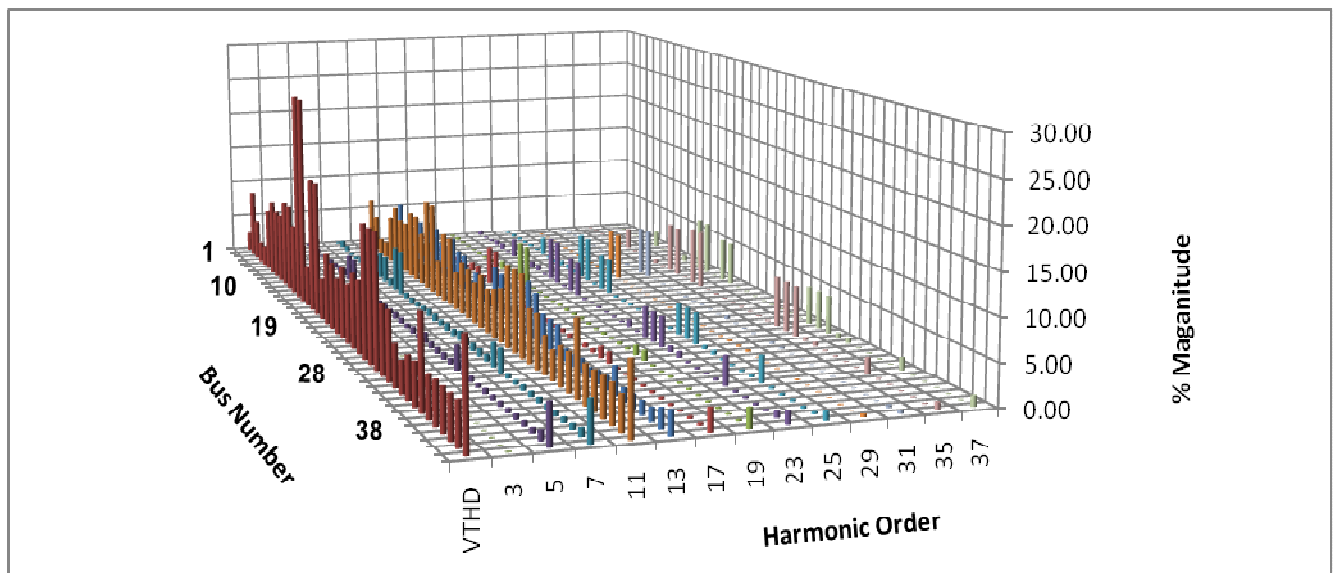

Figure (5.15): The harmonics spectrum of distribution harmonics-producing loads in heavily polluted systems

b. Concentrated harmonics – producing loads in heavy polluted systems

The nonlinear loads are concentrated in Bus 32 and Bus 37, with a percentage of 39.4%. The system supplied capacity is equal to 29.5 MVA. Two different compositions have been studied: 12-pulse VFD and 18-pulse VFD are combined in Case 1, while Case 2 has two 18-pulse VFDs. Table 5.7 shows the details of the system configuration for both cases.

Table (5.7): Concentrated harmonic-producing loads in a heavily polluted system

Case	Bus Number	Bus Voltage (kV)	Device Rating		Type of Nonlinear Device	Percentage of Total System Load
			P(MW)	Q(MVA)		
1	32	2.4	2.975	1.844	12-Pulse VFD	11.87%
	37	13.8	7.458	3.331	18-Pulse VFD	27.23%
2	32	2.4	2.975	1.844	18-Pulse VFD	11.67%
	37	13.8	7.458	3.331	18-Pulse VFD	27.73%

In Case 1, all the system buses – except the utility bus – are polluted by Bus 32 and Bus37, and the 11th and 13th harmonics account for raising the pollution level in the system. The pollution level is higher in the section that is fed from the same bus, Bus 3, which feeds the nonlinear loads Bus 32 and Bus 37. Figure 5.16 illustrates the results of harmonics analysis for Case 1.

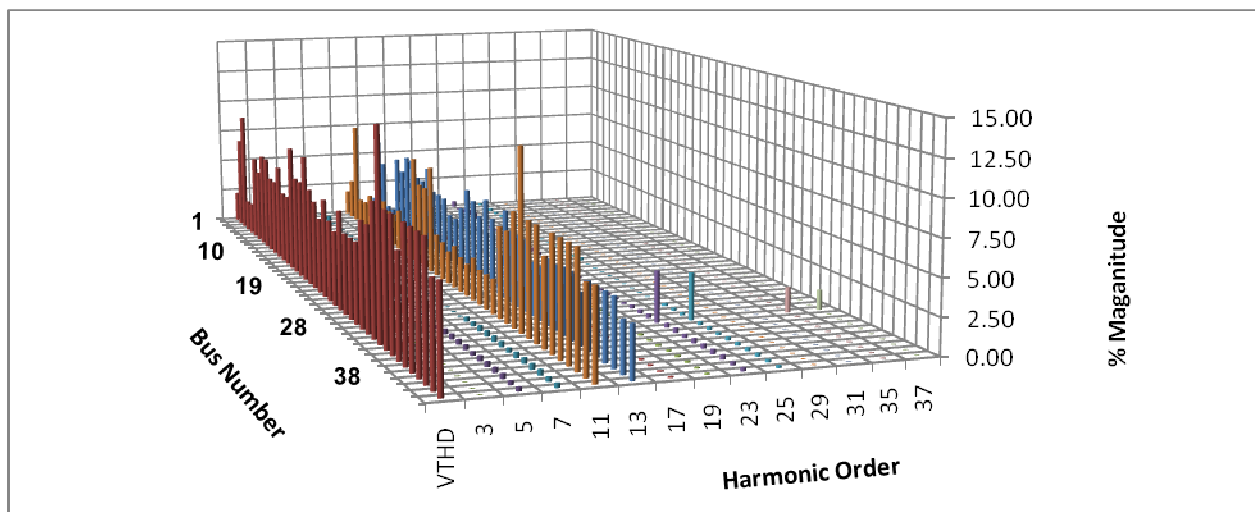

Figure (5.16): The harmonics spectrum of concentrated harmonics-producing loads in heavily polluted systems

When the type of nonlinear load at Bus 32 is changed from a 12-pulse VFD to an 18-pulse VFD, the harmonics performance of the system improves. The heavily loaded buses, Bus 21 and Bus 24, in the section that is fed from Bus 2, have been working within the limits, whereas the rest of the buses at that section have exceeded the IHD_V limit. On the other hand, the only heavily loaded buses in the section that is fed from Bus 3 are not exceeding the THD_V ; nevertheless, the IHD_V limit has been exceeded by most of the system buses in that section. Figure 5.17 presents the improvement of the harmonics spectrum that result from changing the type of nonlinear load at Bus 32.

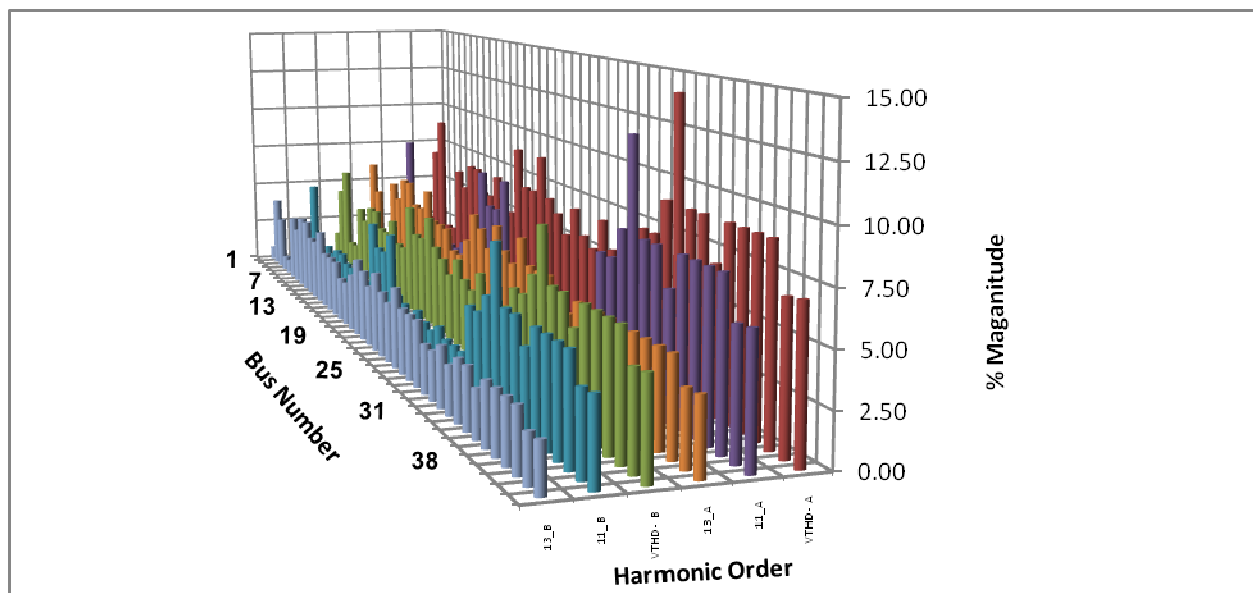

Figure (5.17): Comparison between Case 1 and Case 2 in harmonics spectrum of concentrated harmonics-producing loads of a heavily polluted system

In Case 2, the 11th harmonic currents are responsible for making buses being fed from Bus 3 go over the IHD_V limit, while the 13th harmonics voltages show better performance due to the reduction of the harmonic currents produced from Bus 32; from 5% to 1.2%. So, installing harmonics filters for the 11th and 13th harmonics in Bus 32 and Bus 37 can reduce the harmonics distortion tremendously. When the nonlinear load percentage is changed, the behaviour of the distribution system is changed, too. By investigating different scenarios of harmonics pollution levels in the distribution system, one can notice how the harmonics performance of the network is affected by several factors. These factors and their impacts will be discussed and summarized in the next section.

5.3.4. Discussion of polluted distribution systems

In section 5.3.4, the main remarks and observations from the investigation of polluted distribution systems are highlighted. Rating power, voltage level, type of harmonics-producing device, and network impedance are four factors that influence the harmonics performance in the distribution network. The most important observations are listed in the following:

- When the distance between the harmonics-producing bus and the bus under study is short, the susceptibility and capability of being polluted is high. The distance in the distribution system can be representative of the network impedance.
- Operating at high voltage levels increases the load's impedance; therefore, the ability of being polluted from nearby buses that have lower voltage levels decreases due to the harmonic currents attempting to find shorter paths, with lower impedance, to flow in. However, the amount of power loss that results from the harmonic currents is increased due to the increasing of the loads' impedances.
- The type of harmonics-producing device decides the amount of harmonic currents produced, so when operating at a high power rating, the amount of harmonic currents should be low enough to reduce the harmonics pollution in order to protect nearby buses and the distribution network.
- The ratio between the rating power of harmonics-producing buses and the total system capacity has a crucial impact on the network harmonics behaviour. If the ratio does not exceed 25%, and the harmonics-producing buses are distributed in the network and their individual ratios are limited to 2%, the entire system's buses are protected from any harmonics pollution. However, if the individual ratio of any harmonics-producing bus is larger than 2%, it may exceed harmonic distortion limits, depending on the type of the nonlinear device and its harmonic currents spectrum.
- When the ratio of harmonics-producing buses' loads to the overall system size is greater than 25%, choosing the proper type of nonlinear devices cannot protect the entire system's buses from the harmonics pollution caused by individual harmonics currents. Therefore, studying the network harmonics performance is essential in order to install harmonics filters to eliminate the harmonic currents causing the harmonics pollution.
- A combination of Distributed Generators (DGs) and harmonics filters can be used to mitigate the harmonics pollution. Adding a DG to a heavily loaded bus can de-rate the

bus's rating power, and its interfacing converters can reduce the harmonics currents produced.

- When a nonlinear heavily loaded bus and a linear lightly loaded bus are sharing the same PCC, both buses account for the harmonics pollution produced to the PCC, from IEEE standards' point of view.

By reviewing the models of nonlinear devices in section 5.2, and investigating how nonlinear devices interact in the different types of distribution systems, one can figure out the importance of identifying the harmonics-producing buses. The identification process is simply utilizing the information that the monitoring system provides in such a way that makes the detection of the harmonics-producing buses achievable with a high degree of accuracy. The various techniques involved in detecting and localizing harmonics-producing sources and the methodology proposed are discussed thoroughly in the next section.

5.4. Detecting the harmonics pollution sources

It is helpful to locate the sources of the harmonics pollution when significant harmonic voltage or current distortions have occurred in a power system. Accurate detection of harmonic source locations is important for mitigating the problem and for deciding the responsibility of the parties involved. The most common situation requiring harmonic source detection is to resolve a dispute over who is responsible for harmonic distortions; between a utility and a customer, or between two customers sharing the same PCC [17]. Identifying the source of harmonics pollution can be achieved by single-point measurements and distributed synchronous measurements [12].

Both approaches have their advantages and drawbacks. Single-point measurement methods have some advantages, e.g., easy implementation and low cost. However, under some conditions, they can report inaccurate information about the harmonic state. According to Rens et al. in [15], harmonics distortion measurements cannot provide the required information if they are carried on in a single metering section of the network without changing the network configuration during the measurement process. Several techniques have been proposed to identify the source of harmonics pollution using single-point measurement; however, some of these techniques are based on new concepts that still need thorough investigation before confirming their validity, such as the Norton Equivalent Method and the Thevenin Equivalent Method [5]. Hence, single-point measurement techniques are still under investigation to prove

their validity in order for them to be acceptable [22]. Therefore, distributed synchronous measurements have to be implemented in order to get correct information on the location of the sources of harmonics pollution. Distributed synchronous measurements suffer from the high cost and implementation difficulties; however, using the vertex-colouring optimization technique proposed in Chapter 4 can reduce the cost of the monitoring system tremendously.

The most common method for harmonic source detection is the Total Harmonic Power (THP) method. In this method, the direction of harmonic power flow is checked, and the side that generates more harmonic power is considered to contain the dominant harmonic source or to have a larger contribution to the harmonic distortions observed at the measuring point [17]. The proposed monitoring system can supply all information required for the THP method. The next section will discuss the formulation of the power direction method and its applications.

5.4.1. Total Harmonic Power Method

The total harmonic power (THP) method [30] is a simple method that uses the sign, either positive or negative, of the THP at a specific node to decide on whether the source of harmonic pollution is upstream or downstream from that node. Phase shifts between the voltage and current at different harmonic orders are implemented to determine whether the sign is negative or positive. Therefore, any error in calculating the phase shifts can impact the accuracy of the method. When the phase shifts approach 90° , the error probability is increased. The accuracy of the THP method in identifying the source of harmonic pollution has been queried in [5]; however, the validation of the THP method has been extensively demonstrated by W. Omran et al. in [12].

The principles of the THP method can be demonstrated by using the circuit shown in Figure 5.18. An ideal sinusoidal voltage source is connected through the system impedance \mathbf{Z}_S to a nonlinear load, which is represented by the load impedance \mathbf{Z}_C and harmonic current source \mathbf{I}_C . The nonlinear load generates harmonic currents that flow in the system, causing voltage distortion at the measuring point \mathbf{M} . This voltage distortion depends on both the harmonic currents and the system impedance at harmonic frequencies. The distorted voltage and current at point \mathbf{M} can be expressed by a Fourier series as

$$v_M(t) = V_{M0} + \sum_{k=1}^{\infty} \sqrt{2} V_{Mk} \sin(hw_1 t + \theta_{MkV}) \quad (5.1)$$

$$i_M(t) = I_{M0} + \sum_{k=1}^{\infty} \sqrt{2} I_{Mk} \sin(hw_1 t + \theta_{MkI}) \quad (5.2)$$

Where $V_M(t)$ and $I_M(t)$ are the instantaneous voltage and current at point M ,

h is the harmonic order,

ω_1 is the fundamental angular frequency of the supply,

V_{M0} and I_{M0} are the magnitudes of DC components of the voltage and current,

V_{Mh} and I_{Mh} are the RMS values of the voltage and current at frequency $h\omega_1$,

θ_{MhV} and θ_{MhI} are the phase shifts of the h^{th} harmonic voltage and current with respect to a common reference.

The instantaneous power at any point in the system is determined as

$$p(t) = v(t) \cdot i(t) \quad (5.3)$$

The average power at point M is

$$P_M = \frac{1}{T} \int_0^T p(t) dt \quad (5.4)$$

$$\therefore P_M = V_{M0} \cdot I_{M0} + \sum_{h=1}^{\infty} V_{Mh} \cdot I_{Mh} \cdot \cos(\varphi_{Mh}) \quad (5.5)$$

Where B is the period of supply voltage in seconds

$$\Phi_{Mh} = \theta_{MhV} - \theta_{MhI}$$

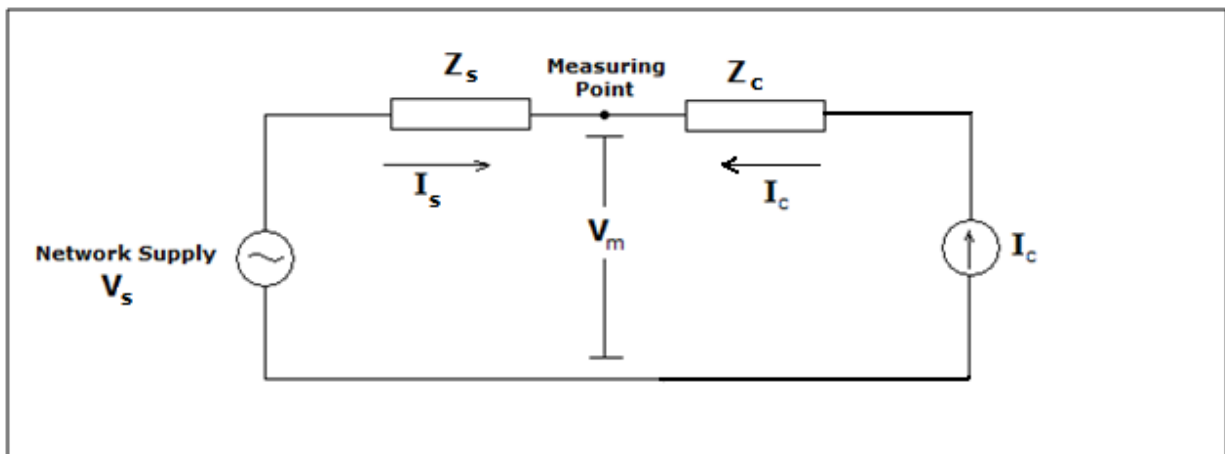

Figure (5.18): Simple network with nonlinear device connected to a sinusoidal supply

$$\mathbf{P}_M = \mathbf{P}_{M0} + \mathbf{P}_{M1} + \mathbf{P}_{Mh} \quad (5.6)$$

Where \mathbf{P}_{M0} is the DC component, \mathbf{P}_{M1} is the fundamental component, and \mathbf{P}_{Mh} is the total harmonic power at point \mathbf{M} .

Assuming that \mathbf{V}_S is an ideal supply, the nonlinear device is the only source of harmonics pollution, and it generates harmonic currents at different frequencies. Thus, harmonic powers, with a total value of \mathbf{P}_{Mh} , flow from the load side to the supply side and are dissipated in the resistance of the system impedance [12]. As a result, the nonlinear device converts power at the fundamental frequency to powers at the fundamental and harmonic frequencies. The THP method suggests that the THP at a certain node is an indication for the existence of a harmonic-producing load. Moreover, the sign of this power can be used to identify the location of the harmonic pollution source in radial systems, as follows [30].

- If $\mathbf{P}_h > 0$ at a certain point in the system, then a harmonic source exists upstream of this point, and the harmonic power is received from the source side.
- If $\mathbf{P}_h < 0$, then a harmonic source exists downstream of the node under study, and the harmonic power is received from the load side.

5.4.2. Applications of the THP method

The THP method has been examined to identify the harmonic-pollution sources. Three different examples are illustrated to testify to the proposed method. A simple three-bus system and 10-bus system are presented.

a. Simple 3-Bus system

A simple 3-Bus system is examined by applying the THP method in order to locate the harmonics pollution source (Figure 5.19). The system has a generator in Bus 1, with 1.5 MW and 13.8 kV. A linear load of 1 MVA is connected to Bus 2, and a 200 KVA nonlinear load is connected to Bus 3. The harmonic flow analysis is carried out using the ETAP 7.1 simulator package, and the results of this analysis are shown in Table 5.8.

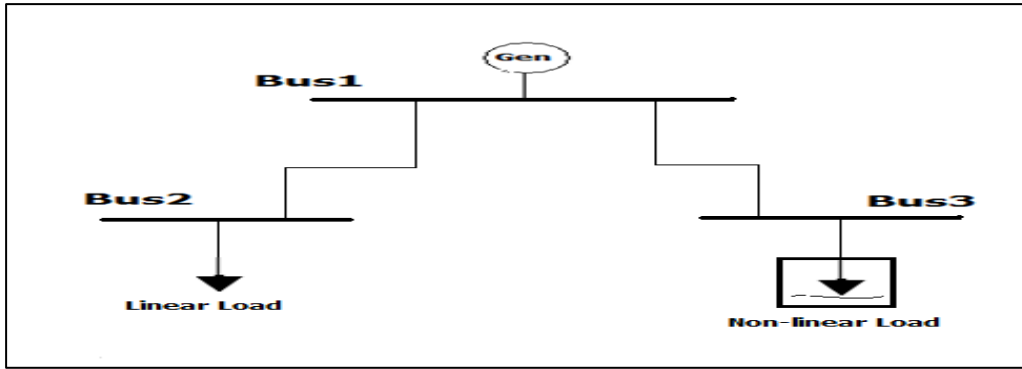

Figure (5.19): Simple network with nonlinear device connected to Bus 3

Table (5-8): Harmonic powers for simple 3-Bus network with a single nonlinear device

Harmonic Powers	Bus 1	Bus 2	Bus 3
P1(MW)	1.3982403	0.85117303	0.4158779
P5(W)	-45.12697	-4.5631933	-44.6246
P7(W)	-20.112218	3.89872138	-22.07874
P11(W)	-16.061749	-1.5275996	-15.41724
P13(W)	-10.076206	3.0483713	-12.51829
P17(W)	7.28417145	-0.2018508	7.859715
P19(W)	-8.2707208	2.21405786	-10.13608
THP(W)	-92.363692	2.86850686	-96.91524

One can indicate from Table 5.8 the following:

- The fundamental power P1 is positive in Bus 1, Bus 2, and Bus 3, and it decreases from the supply bus, Bus 1, to the load buses, Bus 2 and Bus 3.
- The negative sign of THP at Bus1 means that the harmonic-producing device is located downstream with respect to Bus 1.
- The positive sign of THP at Bus2 means that the harmonic-producing device is located upstream with respect to Bus 2, whereas the THP at Bus 3 are negative, indicating that the harmonic-producing device is connected to Bus 3.

b. Industrial 10-Bus system

The system has 2 nonlinear loads, one of each being connected to Bus 5 and Bus 9. Bus 1 is a generation bus. The bus-loading of the system is presented in Table 5.9, and the configuration of the system is shown in Figure 5.20.

Table (5-9): The bus loading for the industrial 10-Bus system

Bus ID	Voltage Level (kv)	P (MW)	Q (MVAR)	S (MVA)
Bus 1	13.8	3.541	2.087	4.11
Bus 3	0.48	0.479	0.202	0.52
Bus 4	13.8	1.441	0.753	1.626
Bus 5	0.48	1.006	0.394	1.080
Bus 6	2.4	0.419	0.259	0.492
Bus 7	13.8	1.614	1.099	1.953
Bus 8	0.48	0.367	0.227	0.431
Bus 9	0.48	1.232	0.763	1.449
Bus 10	0.48	0.553	0.342	0.650

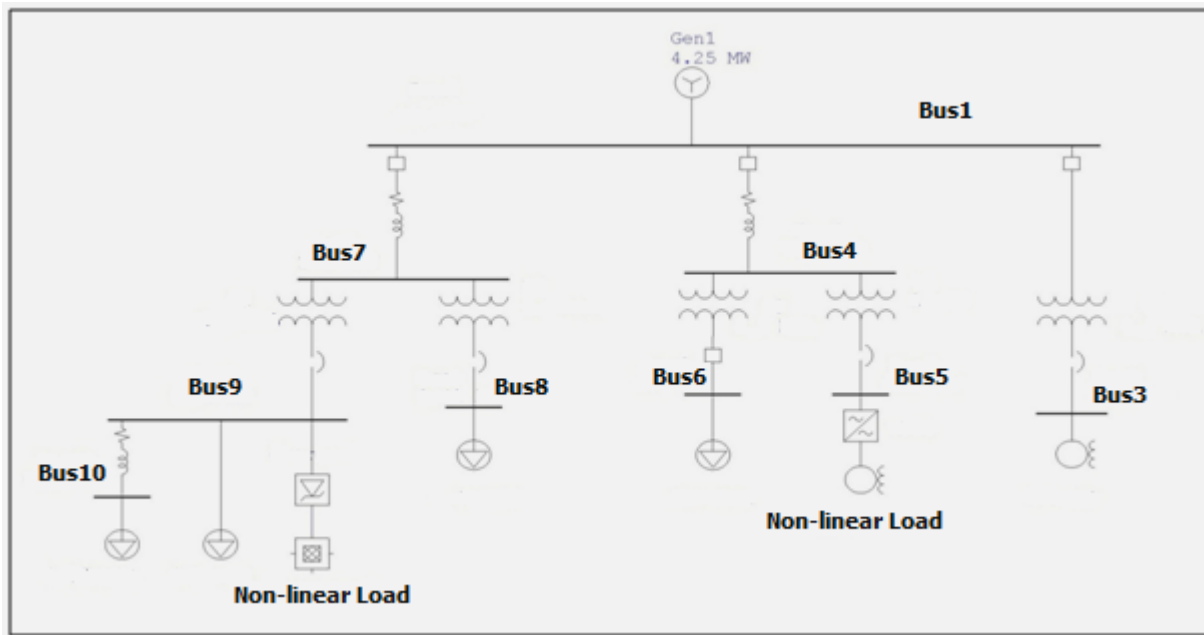

Figure (5.20): The 10-Bus industrial system with two nonlinear loads

The harmonic powers identified from the harmonic flow analysis are listed in Table 5.10. The harmonic flow analysis covers harmonic power flows up to the 25th harmonic. Because the output values from the ETAP 7.1 simulation package are limited to 4 digits after the decimal point, Bus 10 shows zero harmonic power flow, which is not accurate. Bus 10 should have a small amount of power flow to Bus 9. Hence, this is one of the obstacles that faces the THP

method when dealing with high-order harmonics, so another accurate simulation package has to be involved.

Table (5.10): Harmonic powers of industrial10-Bus system with two nonlinear loads

Harmonic Powers	Bus 1	Bus 3	Bus 4	Bus 5	Bus 6	Bus 7	Bus 8	Bus 9	Bus 10
P1(kw)	3539.5	433.1	1452.4	868.13	444.3	1601.6	352.8	1230	550
P5(w)	-0.3606	0.371	-6.71	-7.96	0.181	0.48	0.16	0.33	0
P7(w)	740.02	0.07	1.36	1.169	0.038	0	0	0	0
P11(w)	-792.45	0.435	11.72	14.12	0.24	0.188	0.257	-0.055	0
P13(w)	9.14	-0.44	-22.4	-20.44	-0.324	-1.617	-0.34	-1.29	0
P17(w)	-10.215	-0.011	-0.14	-0.144	-0.0015	-0.011	-0.002	-0.01	0
P19(w)	0.008	0.008	0.3	0.27	0.012	0.045	0.011	0.0332	0
P23(w)	0	0	0	0	0	-1.944	0	-1.96	0
P25(w)	0	0	0	0	0	-2.67	0	-2.65	0
THP(w)	-53.13	0.431	-15.911	-12.991	0.141	-5.531	0.082	-5.607	0

One can observe from Table 5.10 the following:

- All the powers at the fundamental harmonic are positive and the power direction will be from the higher value to the lower, depending on the system configuration in Figure 5.20.
- Bus 1 has negative THP, so the harmonics-producing devices are downstream with respect to Bus 1. That means the sources of the harmonics distortion are located on Bus 3 and/or Bus 4 and/or Bus 7.
- Bus 3 has positive THP; therefore, the harmonic-producing devices are upstream with respect to Bus 3. However, both of Bus 4 and Bus 7 have negative THP, so the harmonic-producing devices are downstream with respect to Bus 4 and Bus 7.
- Bus 4 has two downstream buses: Bus 5 and Bus 6. By checking the sign of the THPs of the two buses, one can indicate that the non-linear load is connected to Bus 5, because it has negative THP where Bus 6 has positive THP.
- Bus 9 has only one downstream bus, Bus 10, and because Bus 10 has zero THP, the identification of the non-linear load using the THP method has been questioned. If Bus 10 has negative THP, the nonlinear load will be connected to Bus 10; otherwise, the nonlinear load will be connected to Bus 9.

- Assuming that both Bus 9 and Bus 10 have non-linear loads, there will be two scenarios for THP's signs.
 - Both the THPs of Bus 9 and Bus 10 are negative: basically, one can say that the nonlinear loads are connected to Bus 10, which is not correct. The problem is not related to the accuracy of the THP method, but is related to the way of detecting the harmonic-producing devices. Using only the sign of the THP is applicable only for the end-users' buses and the connecting buses that have neither loads nor generators connected.
 - The THP of Bus 9 is negative and the THP of Bus 10 is positive: this may happen when a large nonlinear load is connected to Bus 9 and a small one is connected to Bus 10; therefore, the harmonic power can flow from Bus 9 to Bus 10, and if the amount of harmonic power injected by Bus 9 to Bus 10 is greater than the amount of harmonic power injected by Bus 10 into the system, the sign of THP of Bus 10 will be positive. In this case, the effect caused by Bus 9 to Bus 10 will not be noticeable, so Bus 9 will gain from this while Bus 10 will be negatively affected.
- When the bus under study is not an end-user bus or connecting bus, the negative sign of THP can be expressed as *the nonlinear load is located in this bus or downstream* rather than the *nonlinear load is located downstream with respect to this bus*.
- Considering the magnitude of the harmonic powers can be a solution to this problem; however, extensive analysis should be done in order to investigate this alternative solution.

The THP method has many advantages, such as being easy to implement and having a low data requirement for the true RMS voltage and current signals; however, it suffers from the high level of accuracy that is needed in the calculations, and it is not applicable for some distribution network cases. Nevertheless, the performance of the THP method can be enhanced by developing the method of deciding the bus that has the nonlinear load, so the magnitude has to be involved rather than using only the sign, to get accurate results.

5.5. Chapter assessment

Chapter 5 covered many subjects related to detecting harmonics pollution sources. Identifying the harmonics pollution sources can be a solution for limiting the harmonics

pollution in the distribution systems by applying a penalty fee if the injected harmonics exceed the limits. The correct modeling of the harmonic-producing devices is an important step that leads to not only understanding the devices' behaviour, but also to finding the best way for detecting the device. The nonlinear devices are divided into two groups: nonlinear magnetic devices and nonlinear switching devices. Several examples from both groups have been highlighted with their current waveforms and spectrums. After looking at the harmonic-producing devices as standalones, an investigation into how these devices can interact in the distribution system is demonstrated. Different polluted distribution systems are categorised into lightly polluted systems, medium polluted systems, and heavily polluted systems. The ratio of the nonlinear loads to the total system load decides the category of the polluted system. Moreover, the nonlinear loads can be connected in one place, or they can be distributed in the entire system. Both cases have been investigated for all polluted systems categories. How the harmonics pollution level changes when the rating power, the voltage level, the type of nonlinear load, and the network impedance are changed was the most important observation from the investigation. The last section in this chapter focused on the identification methods used to locate harmonics pollution sources in distribution systems. The total harmonic powers (THP) method was proposed as a method for detecting the harmonics sources. The THP method is a simple method that uses the sign of the THP at a specific bus to decide on whether the nonlinear loads are connected upstream or downstream with respect to that bus. Two obstacles can limit using the THP method in detecting the nonlinear loads for distribution systems: the high degree of accuracy in calculation, and that the method cannot detect by using only the sign a nonlinear load connected to a bus that has another nonlinear load connected to one of its downstream buses. The THP method can be developed to solve this problem by using the sign and magnitude of the THP.

Chapter 6

Conclusions and Future Research

The work presented in this thesis aims to investigate the monitoring of power quality in distribution systems. Power quality disturbances are categorized into stationary disturbances, which include voltage variations and harmonic distortion, and non-stationary disturbances, which include transient voltages variations and interruptions. Harmonics distortion is one of the most common power quality problems in distribution systems, and the growth of harmonics-producing devices in distribution systems increases the awareness of harmonic pollution consequences; therefore, harmonics studies have become an important task for designing and analysing distribution systems. As a result, harmonics pollution has to be evaluated in the distribution systems in order to have a deeper understanding of distribution systems behaviour.

Voltage harmonics and current harmonics are the two types of harmonics pollution. Voltage harmonics distortion is responsible for many transient power quality problems, so voltage harmonics gets more attention than current harmonics. The restructuring of distribution systems with an increase in nonlinear loads creates more harmonic currents in the distribution networks. Current and voltage harmonics can be evaluated using different indices: THD and TDD. Voltage harmonics distortion is more important from the utilities' point of view, while keeping current harmonics distortion within limits in order to maintain good power quality is the main issue for end-users.

Electrical power organizations set standards to limit the harmonics pollution in the distribution systems, and an incentive-based regulation has been agreed upon by many as a solution to force customers and utilities to follow these standards. If any customer or utility exceeds the standard limits, they would have to pay a fee related to their harmonics pollution levels. Precise identification of harmonics pollution sources is an essential step in order to apply the incentive scheme properly; however, the identification process requires monitoring the harmonics pollution in the distribution systems.

The large number of sensors needed to monitor the distribution system increases the cost of the monitoring system; therefore, the sensors have to be installed in an optimum way that decreases their quantity and their construction fixed cost. A new optimization approach for

allocating the monitors in the distribution system has been explored. The proposed approach reduces the monitoring system cost by placing the harmonics pollution monitors in minimum-cost locations that can observe all buses and branches of the distribution system. The number of monitors is affected by the percentage of the nonlinear loads in the distribution network; thus, investigations on lightly polluted systems, medium polluted systems and heavily polluted systems have been covered. The relationship between harmonics pollution levels from one side and the nonlinear load types, power ratings, and voltage levels from the other side has been highlighted as an important observation of the polluted systems investigation

The Total Harmonic Powers (THP) method has been used to identify harmonics pollution sources. This method uses the positive or negative sign of the THP at a specific bus to decide whether the nonlinear loads are connected upstream or downstream with respect to that bus. In addition to its simplicity, the THP method is efficient, and requires only the network voltage and current values which can be provided by the proposed monitoring system. The ability to apply the THP method on any distribution system has been examined in order to confirm its validity for different systems.

6.1. Conclusions

The conclusions derived from the investigation conducted throughout this thesis are as follows:

- The harmonic currents consequences appear in electrical systems as voltage distortion due to the interaction between the harmonic currents and the network impedance.
- Capacitor banks have to be designed properly in order to be protected from being a sink for high-order harmonics or from harmonic resonance phenomena.
- Distribution of harmonic pollution monitors in the network limits the system impedance variation impact on assessing the harmonic pollution level.
- The monitor cost fall into two parts: the first part is the fixed cost, which includes the analysing data unit (typical PC) and the transferring data means; the second part is the location cost, which includes the transducer and DAQ costs.
- Reducing the monitoring system cost can be done by minimizing the number of monitors used and by placing the monitors in the least costly locations.

- The packing-covering optimization approach minimizes monitoring system cost by reducing the number of monitors used; however, the proposed vertex-colouring approach minimizes monitoring system cost by reducing the number and location cost of monitors.
- The main advantage of the proposed vertex-colouring approach is the low required input data; only the Existence Matrix, which is an integer representation of the Y-Bus matrix, is required as input. The elements in the main diagonal of the Existence Matrix represent the number of current branches of each bus; however, the non-diagonal elements represent the connections between buses.
- The vertex-colouring reduces the number of current branches monitored; therefore, data redundancy is reduced using the proposed method, which leads to reduction of the media to store the data as well as the bandwidth for sending and receiving the measuring data.
- In order to keep the accuracy of the monitoring system within an acceptable limit, the increase of nonlinear loads in a distribution system will force the monitoring system to install extra monitors to provide the required measuring data.
- The correct modeling of the harmonics-producing devices is an important step that leads to not only understanding the device behaviour, but also to finding the best way for detecting the device.
- When the distance between the harmonics-producing bus and the bus under study is short, the susceptibility and capability of being polluted is high. The distance in the distribution system can be representative of the network impedance.
- Operating at high voltage levels increases the load impedance; therefore, the ability of being polluted from nearby buses that have lower voltage levels decreases due to harmonic currents attempting to find shorter paths and lower impedance. However, the amount of power loss resulting from harmonic currents is increased due to the increase in the loads' impedance.
- When a nonlinear, heavily loaded bus, and a linear, lightly loaded bus share the same PCC, both buses account for the harmonics pollution produced to the PCC from IEEE standards point of view.
- The THP method may not be able to detect by using only the sign the nonlinear load connected to a bus which has another nonlinear load connected to one of its downstream buses, due to the possibility of changing the sign of the downstream bus by the harmonic

currents that are injected into it. The THP method can be developed to solve this problem by using the sign and the magnitude of THP.

6.2. Future Research

The research results in this thesis point to several issues where future research can be done; some of these issues are:

- This study should be extended to cover the effects of daily load variations in the distribution system on monitoring system performance from one side, and on the harmonics pollution level from the other side.
- The impact of the load diversity factor on the harmonics pollution level has to be investigated.
- The cost equation of the monitor has to be developed in order to include the cost of different voltage levels in the distribution system, since the cost of a PT that can be used in 69kV is much higher than a PT installed in a 0.48kV bus.
- This research can be extended to investigate the effects of installing a distributed generator on the concentrated nonlinear load bus from the harmonics pollution perspective.
- The THP method, by taking the THP magnitude into consideration besides the sign for detecting harmonics pollution sources in the distribution system, has to be investigated before its validity can be confirmed.

Bibliography

- [1] "IEEE Recommended Practice for Monitoring Electric Power Quality," IEEE Std. 1159-1995.
- [2] TK Abdel-Galil, EF El-Saadany, and MMA Salama. Effect of new deregulation policy on power quality monitoring and mitigation techniques. In 2001 IEEE/PES Transmission and Distribution Conference and Exposition, volume 1, 2001.
- [3] J. Arrillaga, MHJ Bollen, and NR Watson. Power quality following deregulation. Proceedings of the IEEE, 88(2):246-261, 2000.
- [4] DCS Reis, PRC Villela, CA Duque, and PF Ribeiro. Transmission systems power quality monitors allocation. In 2008 IEEE Power and Energy Society General Meeting-Conversion and Delivery of Electrical Energy in the 21st Century, pages 1-7, 2008.
- [5] W. Xu and Y. Liu. A method for determining customer and utility harmonic contributions at the point of common coupling. IEEE Transactions on Power Delivery, 15(2):804-811, 2000.
- [6] M.H.J. Bollen and I.Y.H. Gu. Signal processing of power quality disturbances. IEEE, 2006.
- [7] DL Brooks, RC Dugan, M. Waclawiak, A. Sundaram, E.C. Inc, and TN Knoxville. Indices for assessing utility distribution system RMS variation performance. IEEE transactions on power delivery, 13(1):254- 259, 1998.
- [8] H.E.L.F.A.N. INDIVIDUAL. REVIEW OF METHODS FOR MEASUREMENT AND EVALUATION OF THE HARMONIC EMISSION LEVEL FROM AN INDIVIDUAL DISTORTING LOAD. 1999.
- [9] B.W. Kennedy. Power quality primer. McGraw-Hill Professional, 2000.
- [10] A. Cataliotti, V. COSENTINO, M. AIELLO, and S. NUCCIO. A Self- Synchronizing Instrument for Harmonic Source Detection in Power Systems. IEEE Transactions on Instrumentation and Measurement, 2005.
- [11] M. McGranaghan, BW Kennedy, M. Samotyj, E.C. Inc, and TN Knoxville. Power quality contracts in a competitive electric utility industry. In Harmonics And Quality of Power, 1998. Proceedings. 8th International Conference on, volume 1, 1998.
- [12] W.A. OMRAN, H.S.K. EL-GOHAREY, M. KAZERANI, and MMA SALAMA. Identification and Measurement of Harmonic Pollution for Radial and Non-radial Systems. IEEE transactions on power delivery, 24(3):1642-1650, 2009.
- [13] L. Cristaldi and A. Ferrero. A digital method for the identification of the source of distortion in electric power systems. IEEE Transactions on Instrumentation and Measurement, 44(1):14-18, 1995.
- [14] L. Cristaldi, A. Ferrero, and S. Salicone. A distributed system for electric power quality measurement. In Instrumentation and Measurement Technology Conference, 2001. IMTC 2001. Proceedings of the 18th IEEE, volume 3, 2001.
- [15] A. P. J. Rens and P. H. Swart, "On techniques for the localization of multiple distortion sources in three-phase networks: Time-domain verification," ETEP, vol. 11, no. 5, pp. 317-322, 2001.
- [16] E. El-Saadany. Power Quality Improvement for Distribution Systems under Non-linear Conditions. 1998. Unpublished doctoral dissertation, University of Waterloo, Waterloo, Canada
- [17] W. Xu, X. Liu, and Y. Liu. An investigation on the validity of power direction method for harmonic source determination. IEEE Power Engineering Review, 22(7):62-62, 2002.

- [18] "IEEE Recommended Practice for Industrial and Commercial Power Systems Analysis," IEEE Std. 399-1997.
- [19] M.H.J. Bollen. Understanding power quality problems: voltage sags and interruptions. Wiley-IEEE Press, 2000.
- [20] G.W. Chang and P.F. Ribeiro. Harmonics theory. Chapter 2, IEEE Tutorial on Harmonic Modeling, 1998.
- [21] "IEEE Recommended Practices and Requirements for Harmonic Control in Electrical Power Systems," IEEE Std. 519-1992, revision of IEEE Std. 519-1981.
- [22] EJ Davis, AE Emanuel, and DJ Pileggi. Evaluation of single-point measurements method for harmonic pollution cost allocation. In IEEE Power Engineering Society Summer Meeting, 1999, volume 1, 1999.
- [23] L. S. Czarnecki, "Comments on active power flow and energy accounts in electrical systems with nonsinusoidal waveforms and asymmetry," IEEE Trans. Power Del., vol. 11, no. 3, pp. 1244–1250, Jul. 1996.
- [24] C. Du, MHJ Bollen, E. Agneholm, A. Sannino, and L. ABB AB. A New Control Strategy of a VSC-HVDC System for High-Quality Supply of Industrial Plants. IEEE Transactions on Power Delivery, 22(4):2386- 2394, 2007.
- [25] E.F. Fuchs and M.A.S. Masoum. Power quality in power systems and electrical machines. Academic Press, 2008.
- [26] R. El Shatshat, M. Kazerani, and MMA Salama. Power quality improvement in 3-phase 3-wire distribution systems using modular active power filter. Electric Power Systems Research, 61(3):185-194, 2002.
- [27] MA Eldery, EF El-Saadany, MMA Salama, and A. Vannelli. A novel power quality monitoring allocation algorithm. IEEE Transactions on Power Delivery, 21(2):768{777, 2006.
- [28] MA Eldery, F. El-Saadany, and MMA Salama. Optimum number and location of power quality monitors. In Harmonics and Quality of Power, 2004. 11th International Conference on, pages 50-57, 2004.
- [29] PJ Talacek and NR Watson. Valuation of harmonic injection costs. International Journal of Electrical Power and Energy Systems, 26(10):741-749, 2004.
- [30] T. Tanaka and H. Akagi. A new method of harmonic power detection based on the instantaneous active power in three-phase circuits. IEEE transactions on power delivery, 10(4):1737-1742, 1995.
- [37] P.F. Ribeiro, D.I. Lamp, C. Fluorescent, S. Motors, P. Resistive, P. Inductive, C.I. Lamp, A. Conditioner, R. Heater, W. Machine, et al. Distribution system and other elements modeling. IEEE Power Engineering Society, Tutorial on Harmonics Modeling and Simulation. IEEE Power Engineering Society, 1998.
- [38] J. Arrillaga and NR Watson. Power system harmonics. Wiley, 2003.
- [39] A. Cataliotti and V. Cosentino. Disturbing Load Identification in Power Systems: A Single-Point Time-Domain Method Based on IEEE 1459- 2000. IEEE Transactions on instrumentation and measurement, 58(5), 2009.
- [40] E. Gunther. Harmonic and Interharmonic Measurement According to IEEE 519 and IEC 61000-4-7. In Transmission and Distribution Conference and Exhibition, 2005/2006 IEEE PES, pages 223-225.
- [41] C. Venkatesh, D.S. Kumar, D.S. Sarma, and M. Sydulu. Estimation and Mitigation of Voltage and Current Harmonics in Distribution Systems.
- [42] VE Wagner, JC Balda, DC Gri_th, A. McEachern, TM Barnes, DP Hartmann, DJ Phileggi, AE Emmanuel, WF Horton, WE Reid, et al. Effects of harmonics on equipment. IEEE Transactions on Power Delivery, 8(2):672{680, 1993.

- [43] K. Wilkosz. Harmonic Sources Localization: Comparison of methods utilizing the voltage rate or the current rate. In *Electrical Power Quality and Utilisation, 2007. EPQU 2007. 9th International Conference on*, pages 1{6, 2007.
- [44] T. Hoevenaars, K. LeDoux and M. Colosino, "Interpreting IEEE STD 519 and meeting its harmonic limits in VFD applications," in *Proceedings of the IEEE Industry Applications Society 50th Annual Petroleum and Chemical Industry Conference, Houston, Texas*, pp. 145 – 150, Sep 15-17, 2003.
- [45] H. Zang and Y. Zhao. Intelligent Identification System of Power Quality Disturbance. In *Intelligent Systems, 2009. GCIS'09. WRI Global Congress on*, volume 1, 2009.
- [46] E. Compatibility. Part 4, Section 30: Power quality measurement methods. Technical report, IEC 61000-4-30.
- [47] S. Perera, VJ Gosbell, and B. Sneddon. A study on the identification of major harmonic sources in power systems. *AUPEC02, Sept-Oct, 2002*.
- [48] T. Pfajfar, B. Blazic, and I. Papic. Harmonic Contributions Evaluation With the Harmonic Current Vector Method. *IEEE Transactions on Power Delivery*, 23(1):425-433, 2008.
- [49] P.A. Laplante. *Electrical engineering dictionary*. CRC Press, 2000.
- [50] J. Van den Keybus, J. Driesen, D. Bartolive, and R. Belmans. Simulation of large numbers of non-linear loads in distribution systems. In *Harmonics and Quality of Power, 2000. Proceedings. Ninth International Conference on*, volume 2, 2000.
- [51] R. Bergeron and K. Slimani. A method for the determination of the customers share of the contribution to the level of harmonic voltage on an electric network. In *IEEE Power Engineering Society Summer Meeting, 1999*, volume 1, 1999.
- [52] R.C. Dugan, S. Santoso, M.F. McGranaghan, and H.W. Beaty. *Electrical power systems quality*. McGraw-Hill Professional, 2002.
- [53] K.M. El-Naggar, H.M. Ismail, and M. Al-Fahd. Harmonic modeling, analysis, mitigation of Kuwait EHV electrical network. *Electrical Engineering (Archiv fur Elektrotechnik)*, 91(3):145-152, 2009.
- [54] M. Davidian and D.M. Giltinan. Nonlinear models for repeated measurement data: an overview and update. *Journal of Agricultural, Biological, and Environmental Statistics*, 8(4):387- 419, 2003.