

**Effect of Thermal Pretreatment on Digestibility of
Thickened Waste Activated Sludge and Primary Sludge in
Two-stage Anaerobic Digestion**

by

Rubaiya Sarwar

A thesis
presented to the University of Waterloo
in fulfillment of the
thesis requirement for the degree of
Master of Applied Science
in
Civil Engineering

Waterloo, Ontario, Canada, 2015

© Rubaiya Sarwar 2015

AUTHOR'S DECLARATION

I hereby declare that I am the sole author of this thesis. This is a true copy of the thesis, including any required final revisions, as accepted by my examiners.

I understand that my thesis may be made electronically available to the public.

Abstract

This study investigated the effect of high pressure thermal (HPTH) pretreatment on the biodegradability of a mixture of primary sludge (PS) and thickened waste activated sludge (TWAS) in single-and two-stage continuous anaerobic digestion. The HPTH was applied to the TWAS only at 150⁰C and 3 bars for 30 minutes. All the systems were operated at mesophilic temperature (35⁰C). The objective of this study was to evaluate the impact of TWAS pretreatment on hydrolysis and fermentation in acid phase digesters and to evaluate potential for increased methane production in the subsequent methanogenic digester. For the two-stage systems, the impact of hydraulic retention time (HRT) on performance was evaluated at two different conditions.

The biodegradability of TWAS after pretreatment was evaluated through BMP tests and an increase of 16% biodegradation was observed with pretreated TWAS (PTWAS) as compared to raw TWAS. The HPTH also increased the solubilisation of TWAS by 25-34%. The biodegradable products generated in the pretreated stage were further hydrolyzed and acidified in the acidogenic stage and produced 2 fold higher VFAs in the pretreated digester compared to the control digester. To evaluate the impact of PT on hydrolysis dynamic tests were employed and a two-component hydrolysis model was fit to the data. The readily biodegradable hydrolysis coefficient (K_r) for the control and pretreated digesters were 3.09 d⁻¹ and 2.53 d⁻¹ respectively. Thus, the overall rates of solubilisation were higher for the control than the pretreated digester. However, the advanced pretreatment stage was capable of producing 10% more VFA/TCOD compared to the control. The dynamic tests showed that despite slower hydrolysis rates in the pretreated digesters this PT was capable of producing higher fermentation products in the pretreated digester of the acidogenic phase.

The results of this study showed that the HPTH pretreatment resulted in about a 30% increase in the methane production in both single and two-stage processes. Also, same yield value of 0.16 L CH₄/ g TCOD added was found for the pretreated digester in two stage system with 10 day HRT and in the control digester of single stage system with 13 day HRT. Thus, integration of pretreatment with two stage digestion yielded similar methane production to that observed with a control that had an extended HRT.

Acknowledgements

First and foremost, I would like to express my gratitude to my supervisor Dr. Parker for his great supervision, professionalism and patience during this research. I am always thankful to him for teaching me how to critically think about everything. I am sincerely grateful that I had the opportunity to work with such a smart, thoughtful, and encouraging supervisor. I cannot thank him enough for all he has done for me.

I am thankful to Dr. Elsayed for always being helpful and kind to me. His valuable advice and nice manner are sincerely acknowledged. I owe him debt of gratitude for his support to work throughout the project.

I want to give my sincere thanks to Mark Sobon and Mark Merlau for their technical assistance and Terry Ridgway for their valuable help in Lab. I am grateful to Bipro Dhar for teaching me several experimental techniques and for patiently answering my many questions. Special thanks go to Robert K. Thomas, Aline Rosa, Cameron Adams and Gary Voorthuyzen for helping me with the operation and maintenance of my bench-scale reactors.

Lastly, I would like to acknowledge the endless support of my mother for taking full responsibility of my three kids. I would like to thank my husband, Mohammad Nazrul Islam who supported my decision to complete graduate studies and encouraged me every step along the way.

Table of Contents

AUTHOR'S DECLARATION.....	ii
Abstract.....	iii
Acknowledgements.....	iv
Table of Contents.....	v
List of Figures.....	viii
List of Tables.....	x
Chapter 1 - Introduction.....	1
1.1 Motivation.....	2
1.2 Objectives.....	2
1.3 Scope.....	3
Chapter 2 - Literature Review.....	4
2.1.1 Introduction.....	4
2.1.2 VSS Removal and Solubilisation.....	7
2.1.3 Other Parameters.....	8
2.2 BMP Tests.....	9
2.3 Acidogenic Phase.....	11
2.3.1 Introduction.....	11
2.3.2 VSS Reduction.....	11
2.3.3 VFA Production.....	11
2.3.4 Dynamic Tests.....	13
2.4 Methanogenic Phase.....	14
2.4.1 Introduction.....	14
2.4.2 VSS Reduction.....	14
2.4.3 Stability of Digesters.....	15
2.4.4 Methane Production.....	16
Chapter 3 - Materials and Methods.....	17
3.1 Thermal Pre-treatment.....	17
3.2 Reactor Design and Materials.....	18
3.3 Operation of Anaerobic Digesters.....	21
3.3.1 Start up of Digesters.....	21
3.3.2 Project Schedule and Sampling Timeline.....	21

3.4 Sampling Protocol.....	23
3.4.1 Pretreated Cycle and Collection.....	23
3.4.2 Anaerobic Digester Monitoring	24
3.5 Sample Analysis.....	24
3.5.1 Suspended Solids	24
3.5.2 TCOD.....	25
3.5.3 sCOD.....	25
3.5.4 Ammonia.....	25
3.5.5 TKN	26
3.5.6 VFA.....	26
3.5.7 pH.....	27
3.5.8 Gas Data.....	27
3.6 BMP Test	27
3.7 Dynamic Test.....	28
Chapter 4 - Results and Discussion.....	30
4.1 Sample Characteristics.....	30
4.1.1 BMP Tests.....	34
4.2 Effects of Pretreatment	37
4.2.1 COD Concentrations and Sludge Solubilisation	38
4.2.2 Suspended Solids	39
4.2.3 Other Parameters.....	41
4.3 Acidogenic Phase Performance	42
4.3.1 Steady State Results	43
4.3.2 Dynamic Tests	51
4.4 Methanogenic Phase Performance	81
4.4.1 Stability of the Digesters.....	82
4.4.2 Comparison of Biogas Production and Methane Yield Among Systems	83
4.5 Overall Removal Efficiencies	88
Chapter 5 - Conclusion	91
Chapter 6 - Recommendation	93
References.....	94
Appendix A System-1	100

Appendix B System-2	104
Appendix C System-3	109

List of Figures

Figure 2.1 Schematic representation of anaerobic decomposition.....	4
Figure 3.1 Apparatus for HPTH pretreatment.....	18
Figure 3.2: Schematic diagram of the process (a) control process, (b) Pretreated process.....	19
Figure 3.3: Two stage CSTR anaerobic digester setup.....	20
Figure 3.4: Project timeline of major operations	22
Figure 3.5: Analytical methods used to determine effects of HPTH on TWAS.....	24
Figure 4.1: BMP test results of raw samples	35
Figure 4.2: Methane yield obtained in BMP test	36
Figure 4.3: Average COD concentrations before and after pretreatment of TWAS.....	38
Figure 4.4: COD Solubilisation in all Systems	39
Figure 4.5: Comparison of suspended solids during pretreatment.....	40
Figure 4.6: pH in acidogenic digesters a) System-1 and b) System-2	44
Figure 4.7: Suspended solids and COD removal in the a) System-1 & b) System-2.....	46
Figure 4.8: COD Solubilisation in Acid Phase digesters	47
Figure 4.9: VFA accumulation in Acid phase for System-1 & 2.....	50
Figure 4.10: pH in digesters for Phase-1 Dynamic test	53
Figure 4.11: VSS concentrations in Phase-1 dynamic test	54
Figure 4.12: sCOD in digesters for Phase-1 dynamic test.....	55
Figure 4.13: Hydrolysis rate constant determination for phase-1 dynamic test a) control, b)pretreated	58
Figure 4.14: Ammonia concentrations in control and pretreated digesters for Phase-1 dynamic test.....	59
Figure 4.15: VFAs in the control digester for Phase-1 dynamic test.....	60
Figure 4.16: VFAs in the pretreated digester for Phase-1 dynamic test	60
Figure 4.17: TCOD concentrations in digesters for Phase-1 dynamic test.....	61
Figure 4.18: pH in digesters for Phase-2 Dynamic test	63
Figure 4.19: VSS concentrations in digesters for Phase-2 dynamic test.....	64
Figure 4.20: sCOD Concentrations in digesters for Phase-2 dynamic test.....	66
Figure 4.21: Hydrolysis rate constant determination for Phase-2 dynamic test a) control, b) pretreated...	68
Figure 4.22: Ammonia concentrations in digesters for Phase-2 dynamic test.....	69
Figure 4.23: Increase of VFAs in the control digester for Phase-2 dynamic test	70
Figure 4.24: Increase of VFAs in the pretreated digester for Phase-2 dynamic test.....	71
Figure 4.25: TCOD concentrations in the digesters for Phase-2 dynamic test.....	72

Figure 4.26: pH in digesters for Phase-3 Dynamic test	73
Figure 4.27: VSS concentrations for Phase-3 dynamic test.....	73
Figure 4.28: sCOD concentrations for Phase-3 dynamic test	74
Figure 4.29: Hydrolysis rate constant determination for Phase-3 dynamic test a) control & b) pretreated	75
Figure 4.30: NH ₃ -N concentrations in Phase-3 dynamic test.....	78
Figure 4.31: VFAs in control bottle for Phase-3 dynamic test	79
Figure 4.32: VFAs in the pretreated bottle for Phase-3 dynamic test.....	79
Figure 4.33: Comparison among phases in dynamic test.....	80
Figure 4.34: COD concentrations in the methanogenic phase of the Systems	84
Figure 4.35: Methane Yield in all systems for TCOD added	85
Figure 4.36: Final TSS concentration in all Systems.....	88
Figure 4.37: Overall VSS destruction in all Systems.....	89
Figure 4.38: Final ammonia concentrations in all Systems	89

List of Tables

Table 3-1: Anaerobic digesters sampling timeline.....	23
Table 4-1: Characteristics of Raw PS samples	31
Table 4-2: Characteristics of the Raw TWAS samples.....	32
Table 4-3: Biodegradability determination of raw sludge	37
Table 4-4: Impact of PT on additional parameters.....	41
Table 4-5: Other parameters of Acid phase digesters	51
Table 4-6: Initial conversion rates in Phase-1 dynamic test	54
Table 4-7: Single and dual model hydrolysis values with RMSE for Phase-1 dynamic test.....	56
Table 4-8: Initial conversion rates in Phase-2 dynamic test	64
Table 4-9: Hydrolysis kinetics in Phase-2 dynamic test	66
Table 4-10: Rate of parameters in Phase-2 dynamic test.....	74
Table 4-11: Single and dual model hydrolysis values with RMSE for Phase-3 dynamic test.....	76
Table 4-12: Stability parameters for the Methanogenic phase digesters	83

List of Abbreviations

AD	Anaerobic Digester
CSTR	Continuous Stirred-Tank Reactor
HPTH	High Pressure Thermal Hydrolysis
AC	Acidogenic Phase Digester
MN	Methanogenic Phase Digester
PT	Pretreated
CT	Control
HRT	Hydraulic Retention Time
PS	Primary Sludge
PPS	Pretreated Primary Sludge
TWAS	Thickened Waste Activated Sludge
PTWAS	Pretreated Thickened Waste Activated Sludge
TSS	Total Suspended Solids
VSS	Volatile Suspended Solids
ISS	Inorganic Suspended Solids
TCOD	Total Chemical Oxygen Demand
sCOD	Soluble COD
PCOD	Particulate Chemical Oxygen Demand
NH₃-N	Ammonia Nitrogen
TKN	Total Kjeldahl Nitrogen
ON	Organic Nitrogen
VFA	Volatile Fatty Acids
OLR	Organic Loading Rate
BMP	Biochemical Methanogenic Potential
α	VFA/ Alkalinity Ratio
P	Biodegradable Particulate COD
P₀	Initial Biodegradable Particulate COD
P_{0,s}	Initial Slowly Biodegradable Particulate COD
P_{0,r}	Initial Rapidly Biodegradable Particulate COD xvi
K_{hyd}	Hydrolysis First-Order Constant
K_{hyd,s}	Hydrolysis First-Order Constant for Slowly Biodegradable Particulate COD
K_{hyd,r}	Hydrolysis First-Order Constant for Rapidly Biodegradable Particulate COD
S1	System-1
S2	System-2
S3	System-3

Chapter 1- Introduction

Anaerobic digestion is a well-known process to stabilize sludge and produce valuable methane gas (Anderson et al., 1994). It avoids the use of oxygen and by producing methane is a less energy process for sludge stabilization. However, there is an interest in improving the performance of digestion systems. AD consists of several steps including hydrolysis, acidogenesis, and acetogenesis and methanogenesis processes (Ferrer et al., 2004). The hydrolysis step disintegrates and converts particulate organic matter to simpler substrates such as sugar, amino acids and long chain fatty acids by extracellular enzymes that are present in the sludge. Disintegrating particulates by hydrolysis is relatively slow and requires elevated SRTs (20-30 days) and can lead to low (30-50%) organic matter removal efficiencies (Merlin et al., 2014). In sludge digestion, the rate limiting process is typically the hydrolysis step and this can be accelerated through pretreatment (Bialek et al., 2014). The main mechanism of pretreatment is to rupture the bacterial cell membranes releasing the soluble organic substances and nutrients. Existing pretreatment methods can be broadly categorized as thermal, biological, mechanical and chemical processes (Bougrier et al., 2006). High pressure thermal (HPTH) pretreatment has been demonstrated to be successful both in the laboratory and full scale plants for pretreating thickened waste activated sludge (TWAS) (Burger and Parker, 2013).

In conventional waste water treatment plants, the anaerobic digester is operated with a mixture of primary and secondary sludge (WAS or, TWAS). However PS has been found to be more digestible compared to the TWAS. For example, methane production from PS was observed to be 306 L CH₄ kg⁻¹ VS fed as compared to 146 to 217 L CH₄ kg⁻¹ VS fed for WAS (Bougrier et al., 2006). Hence only pretreatment of TWAS is typically conducted. Two established thermal pretreatment processes are CAMBI and Exelys (Burger and Parker, 2013). There is however little literature on the use of thermal pretreatment prior to digestion in two-stage anaerobic digestion.

The efficiency of anaerobic digestion has been reported to be enhanced by separating it into two stages (Hidalgo et al., 2014). There are several advantages found in two stage processes as compared to single stage operation. It gives the opportunity to grow two different types of bacteria in separate environments where the optimum operating conditions are provided for each organism. It can also prevent the exposure of methanogens to potentially inhibitory volatile fatty acids that are that produced by acidogenic bacteria. Further, it reduces the potential for methanogens to be exposed to pH shocks (Bialek et al., 2014). Hence,

the main objective of this study was to evaluate the effect of HPTH pretreatment of TWAS prior to mesophilic single- and two-stage anaerobic co-digestion of TWAS and PS.

1.1 Motivation

Thermal pretreatment of WAS is the most widely researched and utilized pretreatment method. For more than a decade successful full scale installations of the HPTH process have been reported (Tattersall et al., 2011). HPTH pretreatment has been found to reduce sludge volume and produce Class A biosolids. Reduced sludge production reduces disposal costs and also produces valuable methane gas which is a source of energy. Class A biosolids contain no detectable levels of pathogens and can be utilized on a wider range of agricultural lands (Henze et al., 2008). HPTH was chosen for this study because of its proven potential growing implementation in practice.

Recent studies by Jhang et al. (2014), Hidalgo et al. (2015), C. Li et al. (2014), Xue et al. (2015) have studied either pretreatment or phased anaerobic systems. In these studies pretreatment was either employed ahead of the methanogenic phase digester or the acid phase digester was employed as a pretreatment to increase the hydrolysis step and produce more VFA to obtain more readily biodegradable compounds. In this study, HPTH pretreatment was operated as a separate process before two-stage mesophilic anaerobic digestion systems. This additional step of pretreatment was conducted to observe if the biodegradable compounds created as a result of pretreatment could accelerate the acidogenesis phase HRT and produce more readily biodegradable compounds. The readily biodegradable compounds were expected to be consumed by methanogens in the later stage to produce more methane.

1.2 Objectives

The study was conducted in three stages that assessed HPTH pretreatment performance, acid phase digester performance and methanogenic phase digester performance. The project was conducted in three systems and each system was operated with a parallel process that did not have pretreatment as a control. The objectives of the studies were:

1. Characterization of the raw and pretreated TWAS using analytical and bioassay methods to evaluate how pretreatment may increase the rate and extent of anaerobic digestion.
2. Evaluate the enhancement of hydrolysis and fermentation by pretreatment through dynamic batch tests that were conducted with acid digesters.
3. Compare single stage verses two stage digestion performance with respect to methane production.

4. Evaluate the effect of HRT on two stage digestion of pretreated WAS.

1.3 Scope

This project investigated the impacts of HPTH on TWAS digestion in single stage and two stage anaerobic digesters at mesophilic conditions. The scope of this project included:

1. Characterization of the raw and digested samples with respect to pH, suspended solids and COD and nitrogen species
2. Assessment of the biodegradability and methane yield of the various combinations of TWAS and PS with or without pretreatment with BMP tests
3. Operation of four bench-scale anaerobic digesters (AD) fed with a mixture of PS and TWAS or PTWAS
4. System- 3 was operated as a single stage AD and thus only two digesters were operated.
5. Dynamic tests were conducted in three phases with differing substrate to inoculums ratio to observe the effect of pretreatment on acidogenic phase in terms of hydrolysis rate and fermentation.

Chapter 2 - Literature Review

The literature review section consists of three main parts that address thermal pretreatment, acidogenic digestion and methanogenic digestion. The impact of these treatments on physical biochemical and biological properties of raw sludge (PS and TWAS) are discussed. The four key biological and chemical stages of anaerobic digestion are hydrolysis, acidogenesis, acetogenesis and methanogenesis as shown in Figure 2.1. Among the three main parts of this study the HPTH pretreatment was expected to accelerate the hydrolysis process, while the acidogenic phase was expected to further hydrolysis and fermentation while methanogenic activity was mainly assumed to take place in the second phase digesters

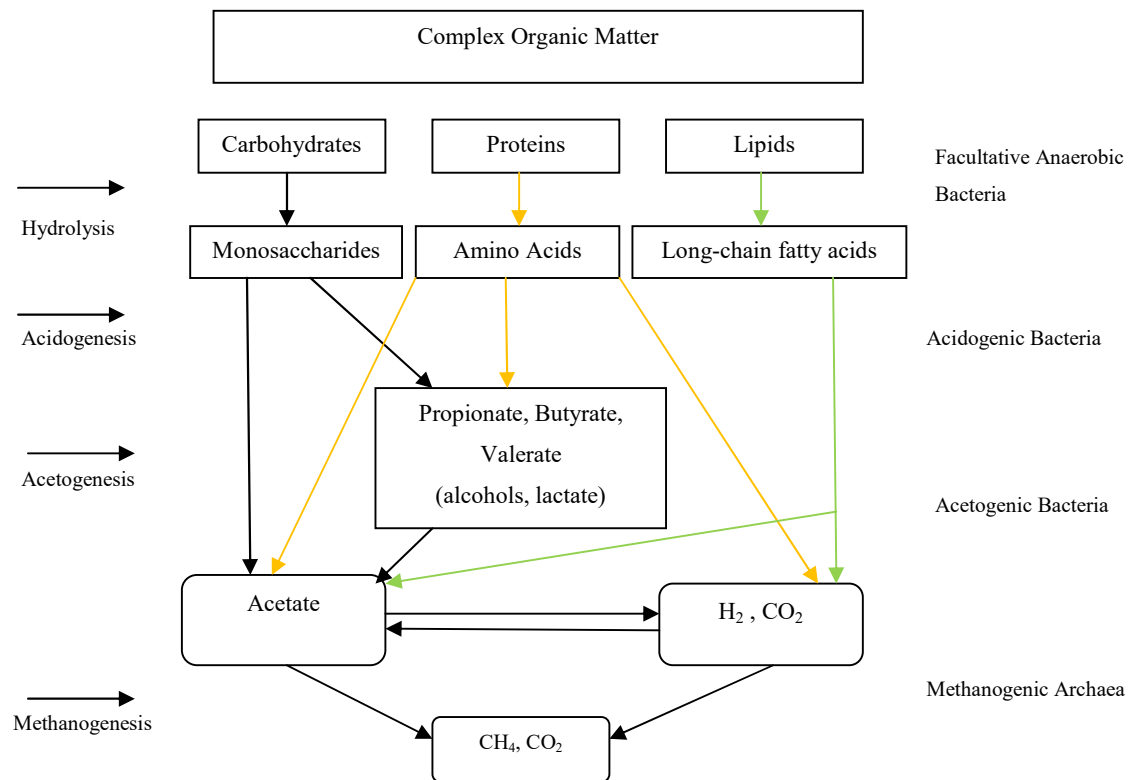

Figure 2.1 Schematic representation of anaerobic decomposition

2.1.1 Introduction

Hydrolysis is known as the rate limiting step in many anaerobic digestion processes (Wahidunnabi & Eskicioglu, 2014). Pretreatment of sludge has been found to increase the hydrolysis rate by rupturing bacterial cell walls that makes organics more readily available to the microorganisms (Carrère et al., 2008). Thus, lower HRT's can be employed thereby minimizing digester volumes and accelerating

methane production. Phothilangka et al., 2008, have shown that the combining anaerobic digestion with HPTH pretreatment could accomplish increased biogas production. HPTH also sanitizes the sludge resulting in enhanced hygienization of sludge that complies with both the European Union (EU) policy on the elimination of pathogens and the Class A bio-solids standard of the US Environmental Protection Agency (USEPA) (Xue et al., 2015). The benefit of producing Class A bio-solids is it provides more diverse options for disposal and land application (USEPA, 1999).

Other than the benefits mentioned above HPTH pretreatment has also been reported to deliver additional benefits. HPTH pretreatment decreases the viscosity of the sludge that allows for improved mixing of digesters and as a result of this; the digesters could be operated at substantially higher organic loading rates (Morgan-Sagasume et al., 2010). Morgan-Sagasume et al. (2010), found that the ratio of acetic to propionic acid generated as a result of fermentation in HPTH was similar that reemployed to biologically remove phosphorous. Thus, the growth of polyphosphate accumulating organisms (PAO) can be enhanced by recycling dewatering streams from the anaerobic digester.

Thermal hydrolysis has been studied in the temperature range of 60⁰ C to 270⁰ C (Climent et al., 2007). Thermal hydrolysis processes can be categorized in two groups; pretreatment below 100⁰ C is considered a low temperature (LT) pretreatment and pretreatment above 100⁰ C under pressure is known as high pressure thermal hydrolysis (HPTH) (Burger, 2012). LT pre-treatment's have been found to increase sludge solubilisation with less energy than HPTH, but do not improve sludge digestion (Nielsen et al., 2004). Xue et al. (2015) reported that gas volume did not increase with temperatures ranging between 60⁰ C and 90⁰ C; whereas pretreatment at temperatures in the range of 140⁰ C to 160⁰ C allowed a reduction of the SRT for digestion from 18–20 day to 12–14 day. Thus, HPTH is more effective to produce biodegradable sludge than LT pretreatment. HPTH pretreatment technologies have been commercialized and are installed in more than 25 full-scale operations worldwide (Burger and Parker, 2013). The most well-known is the CAMBITM technology which is operated in batch mode. Initially the sludge is heated to 80⁰ C, and then the sludge is exposed to thermal hydrolysis at 165⁰ C at 7 bars for 30 minutes.

ExelysTM is another commercial HPTH pretreatment technique which is a continuous plug flow system that uses a series of batch tanks and has been proven to produce Class A biosolids. The operating conditions (temperature, pressure and retention time) of ExelysTM process are similar to those of CAMBITM. An important difference between these two processes is the flash period that is present in the

CAMBI™ process which allows the sludge to enter a flash tank after pretreatment is completed and the steam released is recycled back to heat raw sludge (Morgan-Sagasume et al., 2010). The original purpose of employing the flash period was to disintegrate the sludge however; another study has shown that COD solubilisation remained the same without including the flash period (Gurieff et al., 2011).

Thermal hydrolysis has been found to generate non-biodegradable products beyond a certain temperature depending on the characteristics of the raw sludge (Dwyer et al. 2008). In HPTH temperatures above 200⁰ C have been found to trigger Maillard reactions that will produce melanoidins which are high-molecular-weight heterogeneous polymers. The melanoidins have been found to be hard to degrade and might hinder the degradation of other organics (Xue et al., 2015). Temperatures ranging from 150⁰ C to 190⁰ C may also produce refractory compounds that will add to the effluent as soluble non-biodegradable COD. Dwyer et al. (2008) showed additional solubilised materials as a result of an increase in temperature from 140⁰ C to 165⁰ C, that were non-biodegradable. Therefore, temperature ranging from 140⁰ C to 190⁰ C also solubilize both biodegradable and non-biodegradable COD fractions.

The impact of HPTH on digestion depends on the temperature and duration of the thermal pretreatment. The temperatures and duration of pre treatment varies for a particular raw sludge. Li and Noike, (1992) evaluated heating WAS to temperatures in the range of 62⁰ C to 175⁰ C for durations between 15 and 120 min. Solubilisation and gas production after anaerobic digestion was reported to be highest at 170⁰ C for 60 min and achieved 2 times higher production than a control system. Burger and Parker (2013) applied HPTH on WAS at 150⁰ C for 30 minutes and observed an increase in solubilisation (56% of sCOD) and the rate of aerobic digestion. In many studies the ideal conditions of thermal pre-treatment are selected between 150⁰ C to 180⁰ C for 30 to 60 minutes (Li and Noike, 1992, Valo et al., 2004, Bougrier et al., 2006, Chauzy et al., 2007; Fdz-Polanco et al., 2008; Ramirez et al., 2009). However, the duration of thermal pretreatment has been found to have less influence when compared to temperature (Carrère et al., 2008). Thus, the most important factor in HPTH is the temperature and it should be higher to obtain more solubilisation that led to ultimate biodegradability. Also, the selected temperature should produce less refractory compound to avoid non-biodegradable soluble compounds in effluents.

Based on the literature review, a conservative temperature of 150⁰ C was chosen for the current study with a corresponding pressure of 3 bars for 30 minutes. The selected temperature 150⁰ C is less than the

existing commercial processes (CAMBI™ and Exelys™); whereas the selected duration is similar to them. The pressure is formed inside the vessel without any external support as a result of temperature increase at a constant volume. HPTH of TWAS at this temperature was expected to improve the hydrolysis rate by creating more readily biodegradable compounds and minimizing HRTs in the later two stages and single stage mesophilic CSTR processes.

2.1.2 VSS Removal and Solubilisation

The physical properties of the TWAS are commonly evaluated by monitoring TSS and VSS. This section summarizes literature that describes the impact of HPTH of TWAS on these parameters. The extent of VSS solubilisation can be calculated using equation 2.1.

$$\text{VSS solubilization (\%)} = \left(\frac{\text{VSS}_i - \text{VSS}_f}{\text{VSS}} \right) \times 100 \quad (2.1)$$

In equation 2.1, VSS_i and VSS_f were the VSS concentrations of TWAS before and after pretreatment respectively.

Burger and Parker (2013) employed HPTH at 150⁰ C for 30 minutes at 3 bars on WAS and found 56% of VSS was solubilised after pretreatment indicating that the particulates were more readily available for microorganisms during digestion. Morgan-Sagasume et al. (2010) studied three full scale CAMBI™ plants and showed that the HPTH pretreatment of WAS decreased TSS by 20-30% and this was accompanied by increased solubilisation (sCOD/TCOD ratio increased by 10 fold). Thus, HPTH converted VSS to sCOD which was readily available to the microorganisms during digestion.

HPTH solubilises particulate matter to simple organics and the degree of solubilisation is often employed as an indicator of increased biodegradability of TWAS. In many studies COD solubilisation has been presented as an indicator of the impact of HPTH pretreatment on sludge. The extent of COD solubilisation can be calculated using equation 2.2.

$$\text{COD solubilization (\%)} = \left(\frac{\text{sCOD}_f - \text{sCOD}_i}{\text{PCOD}_i} \right) \times 100 \quad (2.2)$$

In equation 2.2, sCOD_i and sCOD_f were the COD concentrations of TWAS before and after pretreatment respectively. PCOD_i was the initial particulate COD.

Burger and Parker (2013) showed 41% COD solubilisation was achieved for a synthetic WAS at 150 °C. Joshi (2014) reported 35% and 27% COD solubilisation of WAS collected from the Waterloo WWTP as a result of thermal pretreatment at 170 °C and 150 °C respectively. Xue et al. (2015) found COD solubilisation varied from 4.5-53.4% for a temperature range of 120 °C to 180 °C. Donoso-Bravo et al. (2010 b) employed HPTH pretreatment on WAS at a temperature and pressure of 170 °C and 8 bars over a range of times. This study showed that COD solubilisation increased until 15 minutes of pretreatment. However, the COD solubilisation remained constant at 45% for 15 to 30 minutes. Li and Noike (1992) and Valo et al. (2004) reported a solubilisation of 60% after a 170 °C pre-treatment. Bougrier et al. (2007) reported a solubilisation of 34% at 135 °C and 46% at 190 °C. Viewed collectively, COD solubilisation ranged from 28 to 54% at temperature ranging from 150 °C to 170 °C and solubilisation increased with temperature increase. Solubilisation also depended on the duration of pretreatment but after certain duration (15 to 30 minutes) of pretreatment the solubilisation remains constant. To conclude, thermal pretreatment increased the solubilisation of sludge and the duration of highest solubilisation should be determined for a particular type of sludge to avoid longer duration of pretreatment.

2.1.3 Other Parameters

pH, COD, VFA and nitrogen species are often reported as measures of the extent and the rate of digestion increase after pretreatment because hydrolysis is expected to make suspended and particulate compounds more readily available for microbial growth and metabolic activities. Previous studies conducted on the impact of HPTH on these responses are discussed in this section.

Pretreatment accelerates the hydrolysis process by solubilising compounds and as a result pH may change after pretreatment. Maintaining a range of pH (6.6-8.2) is necessary to operate anaerobic digestion (Parker, 2014). Xue et al., (2015) showed the pH of pretreated WAS increased from 7.74 to 7.93 and 7.9 at 120⁰ C and 180⁰ C respectively. There was no noticeable change of pH when HPTH at 60⁰ C to 90⁰ C was employed. Bougrier et al. (2008) showed that the pH of WAS increased from 6.9 to 7.3 after pretreatment at temperatures of 90 °C to 150 °C and then decreased to 6.8 when 170 °C was employed. The pH decrease was attributed to either volatilization of acidic compounds or protein desorption. Burger (2013) reported a pH decline from of 8.5 to 7.8 as a result of HPTH of synthetic WAS generated in a biological reactor in the lab. The pH reduction was attributed to VFA generation during HPTH pretreatment. Morgan-Sagasume et al. (2010) studied full scale plants operating a CAMBI™ process (operated at 165 °C and 7 bars for 30 minutes) and showed that HPTH decreased the pH of the WAS from

an average of 6.7 to 6.2. In summary the literature shows that the pH of sludges after pretreatment is a function of the operating conditions and also depends on the properties of the raw sludge.

Proteins contribute a substantial fraction of the organic matter that is present in sludge. The organic nitrogen present in proteins will ultimately be converted to ammonia when degraded. As a result, the degradation of nitrogen-bearing compounds through HPTH can provide supporting information on the fate of organic matter. Moreover, ammonia is one of the parameters that is of concern for inhibition of anaerobic systems if a threshold value (3000 mg/L) is exceeded. Thus, information on the increase of ammonia during HPTH was of interest. Most of the studies conducted on HPTH have reported conservation of TN through pretreatment (Burger and Parker, 2013, Donoso-Bravo et al. 2010, Bougrier et al., 2008, Gurieff et al. 2011). Burger (2013) suggested that proteins were converted to polypeptides as a result of HPTH. Bougrier et al. (2008) found that the release of ammonia increased with pretreatment temperature when it was below 90 °C and above this temperature the concentration of ammonia remained constant. Morgan-Sagasume et al. (2010) reported NH₄⁺-N increased 0.3 to 0.8 g N/L at the Fredericia plant and 0.7-0.9 g N/L at the Næstved plant where the CAMBI™ process was employed on thickened WAS at 160 °C and 6 bar. Thus, depending on the characteristics of the raw sludge and temperature some HPTH have been observed to only solubilise proteins whereas; some studies have observed direct release of ammonia.

2.2 BMP Tests

The biodegradability of the TWAS is expected to improve through HPTH pretreatment and hence this biological property was of interest. The BMP test has been employed to estimate the biomethane potential of a variety of substrates (Elbeshbishy et al., 2012; Kianmehr, 2010; Raposo et al., 2011; Labatut et al., 2011). All these studies have employed somewhat similar procedures for the BMP test however there is no standard detailed procedure available (Elbeshbishy et al., 2012). In general, two different procedures for conducting the BMP test have been reported. The first approach is known as the blank assay while the second is the German guideline for fermentation tests (Elbeshbishy et al., 2012). In the blank assay tests, separate assays are conducted with inocula alone to estimate the methane production from this source. In the German guideline for fermentation tests, the inocula are pre-incubated for approximately 5 days and no substrate addition is done during this time. This procedure eliminates the need for a seed blank and the waste of sample. However, a longer period of incubation might be required with this approach. As a result, the blank assay approach was utilized in this study.

The biodegradability of the sludge obtained from the batch high solids BMP test depends on the substrate to inoculums ratio. Elbeshbishy et al. (2012) found for the Guelph's inoculums, a lower S/X ratio resulted a higher methane yield with a maximum value of 340 ml CH₄/g TCOD at an S/X of 0.25 g COD substrate/g VSS inoculum. Thus, higher inoculums might result in lower biodegradability results. According to the literature too high a value of S/X may result in a toxic environment inside the bottle because of inhibition and too low S/X may hinder the biodegradation process as a result of lack of microorganism (Prashanth et al., 2006, Raposo et al., 2006). Lesteur et al. (2010) proposed the use of a high S/X ratio (1 to 3) to limit the endogenous biogas production and hence avoid any bias in results. A wide range of S/X ratios have been reported in the literature (0.5-5.7 g VS substrate/g VS inocula) (Elbeshbishy et al., 2012). Therefore, the important factors affecting the biodegradability result of a BMP test are the high S/X ratio (greater than 1).

The characteristics of inoculums and the amount added to BMP test also effects the test results. For example, the maximum biodegradability was lower for Toronto's inoculums because of higher initial concentration of soluble compounds that led to higher gas production in the blank. Jensen et al. (2011) recommended that the inocula used in the BMP test should be collected from a complex feed material operated reactor to ensure a diverse and balanced microbial population. Thus, the inoculums source plays a significant role in the BMP test results and obvious seed source from a waste treatability can lead to flawed data interpretation and conclusion by underestimating ultimate biodegradability.

The extent of anaerobic biodegradability can be calculated from BMP data using the experimental methane generated and the theoretical value. Equation 2.2.; Zamanzadeh, 2012).

$$I_b = \frac{V_{CH_4}}{350 \times M_{COD}} \quad (2.3)$$

Where,

i_b = Biodegradable fraction of sludge;

V_{CH_4} = Volume of total cumulative methane generated;

M_{COD} = Mass of initial COD measured before incubation;

350 = Theoretical volume of methane generation (ml) per g COD at STP;

2.3 Acidogenic Phase

2.3.1 Introduction

Phased anaerobic digesters have several benefits in terms of solids destruction when compared to single-stage CSTR systems (Pohland and Ghosh, 1971). The two main groups of microorganisms in an anaerobic environment are acidogens and methanogens. These two groups have kinetically different characteristics and are able to dominate in separate phases. An equal number of acidogenic and acetogenic bacteria in single- and two-phase anaerobic digesters were reported by Zhang and Noike (1991). Thus, it was concluded that by separating the phases maximum utilization of acidogenesis took place.

The phases are typically separated by employing different HRTs for each phase. Usually, the acidogenesis phase has a short HRT while the methanogenic phase requires a longer HRT (Zamanzadeh, 2012). In prior studies, the HRT for the acidogenic phase has varied from 1-5 days whereas; the methanogenic phase required more than 7 days (Zamanzadeh, 2012). Both thermophilic (50 to 60 °C) and mesophilic (30 to 38 °C) temperatures have been employed to operate the digesters (Han et al., 1997). Thermophilic temperatures were employed to enhance the hydrolysis process inside the digester (Ge et al., 2010). Therefore, less than 7 days HRT were found to be suitable for acidogenic phase along with mesophilic temperature operated digester.

2.3.2 VSS Reduction

This section describes the result of studies that have assessed acidogenic digesters operated with lower HRTs (1-5 days). Jang et al. (2014) reported a 27% VSS reduction efficiency in a 1 day SRT thermophilic AD (TAD) that was employed as a pretreatment stage for a methanogenic digester. Eastman and Ferguson (1981) studied the acid phase anaerobic sludge digestion treating municipal primary sludge. The HRT in the acidogenic phase digestion system varied from 1 to 3 days and the highest VSS reduction of 19% was obtained at 1.5 days. In this study, the VSS reduction decreased as HRT increased. Thus, viewed collectively VSS removal from 19% to 27% was observed for acidogenic phase within 1 to 5 days.

2.3.3 VFA Production

VFAs are the product of acidogenesis that occurs in the absence of external electron acceptors (Gujer and Zehnder, 1983). VFAs are produced from the fermentation of three organic groups that are produced through hydrolysis (simple sugars, amino acids and long chain fatty acids). VFAs and other intermediates

that dissociate and generate protons can lower the pH a digester if they accumulate. The acidogenic phase HRT is typically set at as low value to enhance the establishment of an acidic environment by washing out methanogenic bacteria (Parker, 2005). The pH has been found to range from 5 to 7 for the acidogenesis phase if there is no external control (Min et al., 2005). However, in order to maintain an acid environment with lower pHs some studies have controlled pH. For example, Mespolim et al. (2015) also controlled the pH and maintained 5.5 pH for the entire experimental period to ensure VFA production in the acidogenic phase by automated dosing of 1 M hydrochloric acid. Partial methane production has been reported at pH values of 6.2-6.5 but at pH values of 5.5 the activity of methanogens ceases (Min et al., 2005). Thus, if methane production is to be minimized in the acid phase digester the pH might need to be controlled with acidic chemical addition if it is not maintained by the raw feed sludge between pH 5 and 6.

The impact of HRT on the production of VFA and sCOD is of interest as this is a key design parameter for acid phase digesters. It is expected that the production of VFA will increase with increased HRT because this determines the contact time between bacteria and substrate. Therefore, increased HRT should increase the rate of degradation of the substrate and produce more sCOD and eventually more VFAs. However, some researchers have found decreased VFA production with increasing HRTs (Min et al., 2005, Elefsiniotis and Oldham, 1994, Mespolim et al., 2015). Min et al. (2005) reported highest production of VFA at 2.7 days with a value of 0.17 mg VFA/mg VS and no further VFA increase was observed up to an HRT of 8.2 days. Mespolim et al. (2015) reported the amount of substrate COD converted into residual VFA in the acidogenic reactor were 27.5, 28.4 and 36.6 g COD for the 5, 3 and 2 d HRTs, respectively and as a result the impact of varying HRTs were negligible. Morgan-Sagasume et al. (2010) observed no significant change of VFA production ($0.5\text{--}0.6 \text{ gVFA}_{\text{COD}} / \text{g sCOD}$) between 1 to 6 days HRT regardless of operating conditions. Therefore, VFA production was found independent of HRTs and the decreased VFA production in some studies could be a result of methanogenesis activity due to higher HRT for that particular system.

VFA and COD production trends have been found to depend on the substrate used. An increasing trend in VFA production rate ($.04\text{--}.08 \text{ gVFA} / \text{g VS/d}$) was observed with an increase in HRT (1-5 days) for 10 wt % food wastes and an opposite trend ($.14\text{--}.02 \text{ gVFA} / \text{g VS/d}$) was observed with 25 wt % food waste that was mixed with primary sludge (Min et al., 2005). Morgan-Sagasume et al. (2010) found, the VFA yields observed in HPTH sludge fed systems ($0.2 \text{ g VFA}_{\text{COD}} / \text{g TCOD}$) were up to 2-fold higher compared to

raw sludge fed digesters. Thus, it can be concluded that depending upon the substrate used the VFA might increase or decrease with HRTs and that pretreated substrate yields are higher (2-4 fold) as compared to raw substrates.

2.3.4 Dynamic Tests

The rate of hydrolysis of TWAS and PTWAS was determined through dynamic tests. The hydrolysis process is known as an extracellular and partly non-biological process. In this process the readily biodegradable matter is produced by rupturing the cell membranes of complex particulate organic matter. The acidogenic phase is usually assumed to accelerate the hydrolysis rate to generate more readily biodegradable compounds that will yield more methane in a later phase.

Hydrolysis kinetics are commonly described with a first-order relationship under constant pH and temperature (Batstone et al., 2002). However, the simplification of the hydrolysis process has been found to be insufficient when describing the hydrolysis of particulate matter. Hence, more elaborate models that consider the readily and slowly biodegradable fractions of the sludge have been recommended (Yasui et al., 2008; Ramirez et al., 2009). Further the hydrolysis rate of a substrate is dependent on the acclimation of the anaerobic biomass (Gavala et al., 2003). Therefore, a major fraction of PCOD which are readily biodegradable as a result of HPTH, are expected to be hydrolyzed and fermented in the acidogenic phase digesters and only slowly hydrolysable particulates will pass through for further hydrolysis in the methanogenic phase.

The presence of hydrolysable matter is different in PS and TWAS and as a result the hydrolysis rate constants also vary. Yasui et al., 2008, reported different nature of hydrolysable matter in the primary sludge (PS) and waste activated sludge (WAS). The major portion (75%) of PS is slowly hydrolysable matter and for WAS it is mainly heterotrophic biomass (50-75%). The slowly hydrolysable fraction of PS and WAS is also different and different rates of hydrolysis has been reported under anaerobic conditions in studies (Yasui et al., 2008; Yasui et al., 2006). On the basis of this background, both single and dual hydrolysis models were employed in the current study to examine which model best described the hydrolysis process in the acidogenic phased digestion system.

The hydrolysis rate constant is an important parameter to quantify when assessing whether use of an acidogenic phase accelerates the hydrolysis process. Eastman and Ferguson (1981), reported a hydrolysis

constant for the biodegradable particulate COD in the range of 0.11 to 0.20 d⁻¹ at 35 °C and a pH range of 5.14 to 6.67. As can be seen from the reported hydrolysis rate constants, pH and temperature can considerably influence the rate constant. Zamanzadeh (2012), reported, readily biodegradable hydrolysis constants, $K_{hyd,r} = 1.88$ and 4.63 d⁻¹ and slowly biodegradable hydrolysis constants $K_{hyd,s} = 0.094$ and 0.133 d⁻¹ for mesophilic and thermophilic digesters respectively with a 3.5 day HRT. Thus, increased pH and temperature have been found to increase the hydrolysis rate constant.

In the current study, the readily and slowly hydrolysable fractions in the sludge were evaluated to determine if pretreatment generates readily biodegradable products. Zamanzadeh (2012), found the rapidly hydrolysable and slowly hydrolysable fractions raw mixed sludge of 36% and 25% respectively. Straub et al. (2006) reported 44 and 31% for the rapidly and slowly hydrolysable fractions of a primary sludge only. Yasui et al. (2006) reported a value of 53% for the slowly and 20% for the rapidly hydrolysable particulates for hydrolysis of WAS. Therefore, readily hydrolysable fraction was found lower in WAS compared to PS or mixed sludge.

2.4 Methanogenic Phase

2.4.1 Introduction

In two stage systems the methanogenic phase digester is fed the effluent of the acidogenic phase digester to convert simple organics into methane (Dareioti and Kornaros, 2015, Mespolim et al., 2015). According to the literature, the methanogenic phase requires an HRT of more than 7 days (Min K.S. et al., 2005). Both thermophilic (50 to 60 °C) and mesophilic (30 to 38 °C) temperatures have been employed in the operation of anaerobic digesters (Dague et al., 1996). Improved performance and operational stability have been reported with two-phase anaerobic digesters operating at high organic loading rates (Pohland and Ghosh, 1971; Ghosh 1978) as compared to single stage operation. This section summarizes pertinent literature on the performance of the methanogenic stages of two stage anaerobic digestion.

2.4.2 VSS Reduction

Improved VS removal efficiencies have been reported for two phase digestion systems when compared to single stage digesters with shorter HRT (Ghosh, 1987, Bhattacharya et al., 1996; Han and Dague, 1997; Vandenburg and Ellis, 2002; Skiadas et al., 2005; Nges and Liu, 2009). One study reported VSS reduced 45% at 40 day HRT in the control system whereas; the same VSS destruction was obtained

within 10 day HRT when a thermophilic pretreatment was applied in the previous stage for 1 day SRT (Jhang et al., 2014). Dareioti et al. (2015) operated a two stage system at three HRTs (24, 16 and 12 day) in a methanogenic stage following an acidogenic stage (HRT varied from 5-0.5 day).The highest VS removal efficiency observed was 70%, at an HRT of 16 day in the methanogenic phase when compared to the single stage system. The studies mentioned above have found higher removal (40% to 70%) of organic content compared to single stage systems. Thus, two stage systems can reduce the HRT while achieving higher VSS destruction.

It has also been found that two stage systems are beneficial when operated at lower HRT. Mespolim et al. (2015) operated two stage systems and the VS destruction was compared with the single stage digester where no significant differences were observed for 30 and 20 day HRT. However, for 12 day HRT the VS destruction was 26% and 35% in the single stage and stage system respectively. Hence, two phase system was beneficial over conventional single stage when lower (less than 20 day) HRT system is operated as higher HRTs tend to achieve similar VSS destruction in both with or without pretreated digesters.

2.4.3 Stability of Digesters

The pH is an important indicator of stable digester condition in methanogenic systems. Other than pH, the TVFA/alkalinity ratio is another indicator of process stability. In the literature a ratio less than 0.3–0.4 has been reported to be indicative of a stable condition. Dareioti et al. (2015) operated an anaerobic mesophilic co-digestion of ensiled sorghum, cheese whey and liquid cow manure in a two-stage CSTR system. This study found stable pH for HRT values of 24 and 16 days and the pH was around 8. However, at a lower HRT of 12 day the pH decreased to 6.63, as a result of VFA accumulation and methanogenesis inhibition. The TVFA/alkalinity ratio ranged between 0.02 to 0.15 for 24 day and 16 day HRT whereas; the ratio was found to be 2.32 for a 12 day HRT. Thus, the 12 day HRT was deemed to yield unstable digestion on the basis of this indicator. To avoid this situation, Mespolim et al. (2015) controlled the pH of both stages by adding buffers. The pH of the methanogenic phase for 25, 17 and 10 days was maintained as pH 7. Jhang et al., (2014) conducted a thermophilic aerobic digestion as sludge pre-treatment for a mixture of primary and secondary sludge samples. The pH values of the mesophilic anaerobic digestion system ranged between 7.0 and 7.5 until the 20-d SRT but again instability of digester was observed due to decreasing pH at 10 day HRT Viewed collectively most of the studies maintained stable methanogenic digestion conditions for HRTs above 16 days and below that instability was observed. Thus, a system operated at an HRT below 16 days with two stage operational conditions should be stable and maintain proper pH and alkalinity to enhance methanogenesis process.

2.4.4 Methane Production

The goal of methanogenic digesters is to maximize methane production with minimum HRT. In the two stage process acidification is maximized using an acidogenic phase digester and readily biodegradable matter in the form of VFAs is introduced to the methanogenic digester. It is typically assumed that the methanogenic digester will be able to consume the readily available substrates and convert them into methane. Mespolim et al. (2015) observed a 40% increase in methane yield ($L\ CH_4/ g\ COD\ added$) in a two stage system (acidogenic phase HRT=2 day and methanogenic phase HRT=10 day) compared to single stage with similar HRT of 12 day. Jhang et al. (2014) reported an increment in methane production rate of approximately 42%, when a thermophilic anaerobic digester (TAD) with a 1 day SRT was operated ahead of a methanogenic digester. Hidalgo et al. (2014) compared a two phase system and a single phase system with residues from the used vegetable oil processing industry (OW) and with pig manure (PM) in semi-continuous sequencing digesters operated at mesophilic temperature for 20 day HRT. The results obtained from this study showed that for a feed ratio of OW/PM1:3 v/v, average biogas production was $0.33\ m^3 /kg\ VS\ removed$, with a methane content 66 % in the single stage system whereas; the two phased system (first stage with 2-3 day HRT) produced an average biogas production of $0.40\ m^3 /kg\ VS\ removed$ with a methane content of 67 %. The biogas production was 21% higher with similar methane content compared to the single phased system. Hence, the two stage system had a noticeable increase of methane production compared to control systems. To conclude, higher methane yield was achieved for two phased systems compared to single phased digestion.

Chapter 3 - Materials and Methods

Two types of feed sludge (PS and TWAS) were used in this study and they were transported from the source wastewater treatment facility once every two weeks inside a cooler that was loaded with icepacks. The primary sludge was collected from the primary clarifier that had an HRT of 3 hours. The TWAS was collected from the effluent of a dissolved air flotation (DAF) system. The TWAS that was thickened through the DAF was obtained from a secondary clarifier. The samples were stored separately at 4⁰ C, and the required volume of feed was obtained daily; two hours prior to feeding. Physical, biochemical and biological properties of the raw PS, raw TWAS, PTWAS, and digested samples were assessed by common laboratory analyses and BMP testing was conducted on raw and pretreated samples to characterize biodegradability. Pretreatment was conducted on the TWAS only, and the feeds to the digesters were a mixture of either TWAS or PTWAS with PS.

3.1 Thermal Pre-treatment

High pressure thermal pretreatment of TWAS was performed with a mini pressure reactor (Parr® Model 4563) with a working volume of 400 ml. The process used for HPTH in this study is shown in Figure 3.1. The TWAS was pretreated at a temperature of 150°C and pressure of 3 bars for 30 minutes. The heater required 30 minutes to reach 150⁰ C, then 30 minutes were given to complete the pretreatment and finally another 45 minutes were required to cool down the reactor vessel to 40⁰ C before opening it. A thermocouple attached with the reactor vessel was connected to a display to monitor the temperature of the reactor contents. A built-in variable speed motor stirred the sample continuously throughout the process to avoid over heating of the apparatus, and to mix the sample. The reactor was heated with a mantle heater assembly connected to a programmable temperature control. After 30 minutes of operation, tap water was recycled around the vessel enclosing the sample by connecting by flexible tubing on the head of the reactor vessel.

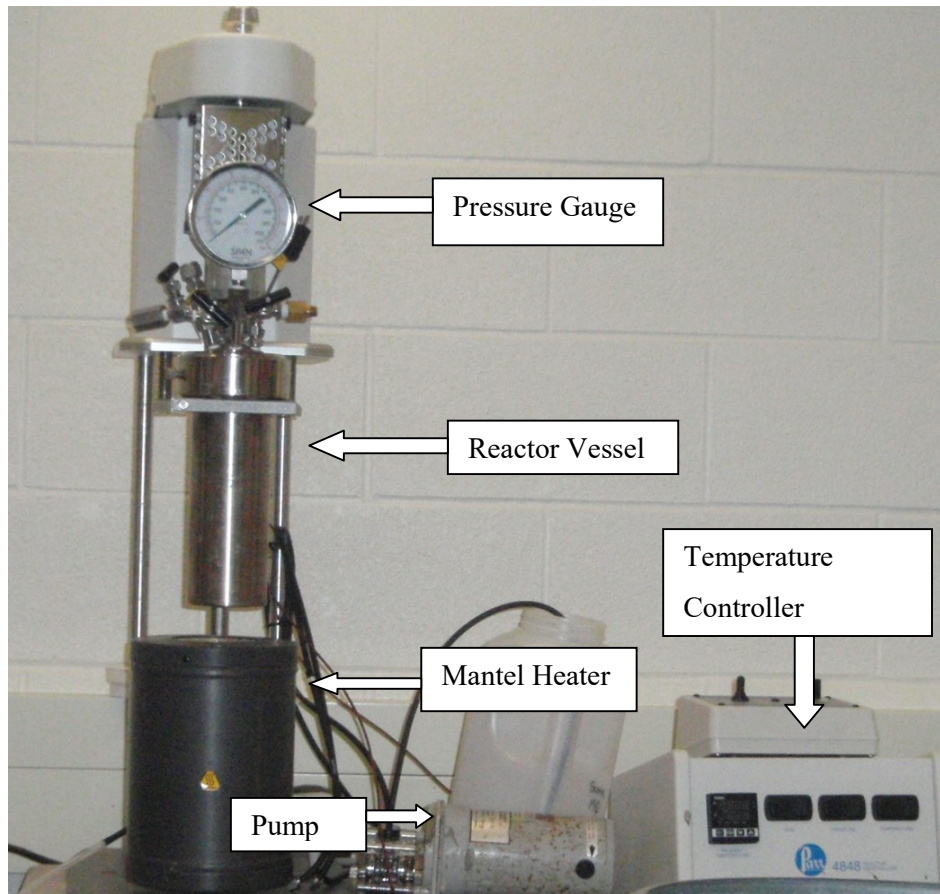

Figure 3.1 Apparatus for HPTH pretreatment.

3.2 Reactor Design and Materials

The impact of pretreatment on TWAS biodegradability was assessed in a long term test with two phase and single phase mesophilic anaerobic digesters. An overall process flow diagram representing the reactor operating conditions is presented in Figure 3.2. This study was conducted as three Systems. System 1 & 2 were operated as two phases whereas, System 3 was operated as a single phase. The two phased system consisted of an acidogenic phase digester and a methanogenic phase digester. Each System consisted of parallel setups, the control and the pretreated digesters. The control digesters were fed with TWAS & PS whereas, the pretreated digesters were fed with PTWAS & PS. All other conditions including HRTs were the same for both the control and the pretreated digesters in each System. System-1 was operated with a 2 day HRT in the acidogenic phase and a 13 day HRT in the methanogenic phase whereas; System-2 was

operated with a 2 day HRT in the acidogenic phase and a 9 day HRT in the methanogenic phase. System-3 was operated as single phase, with a 13 day HRT.

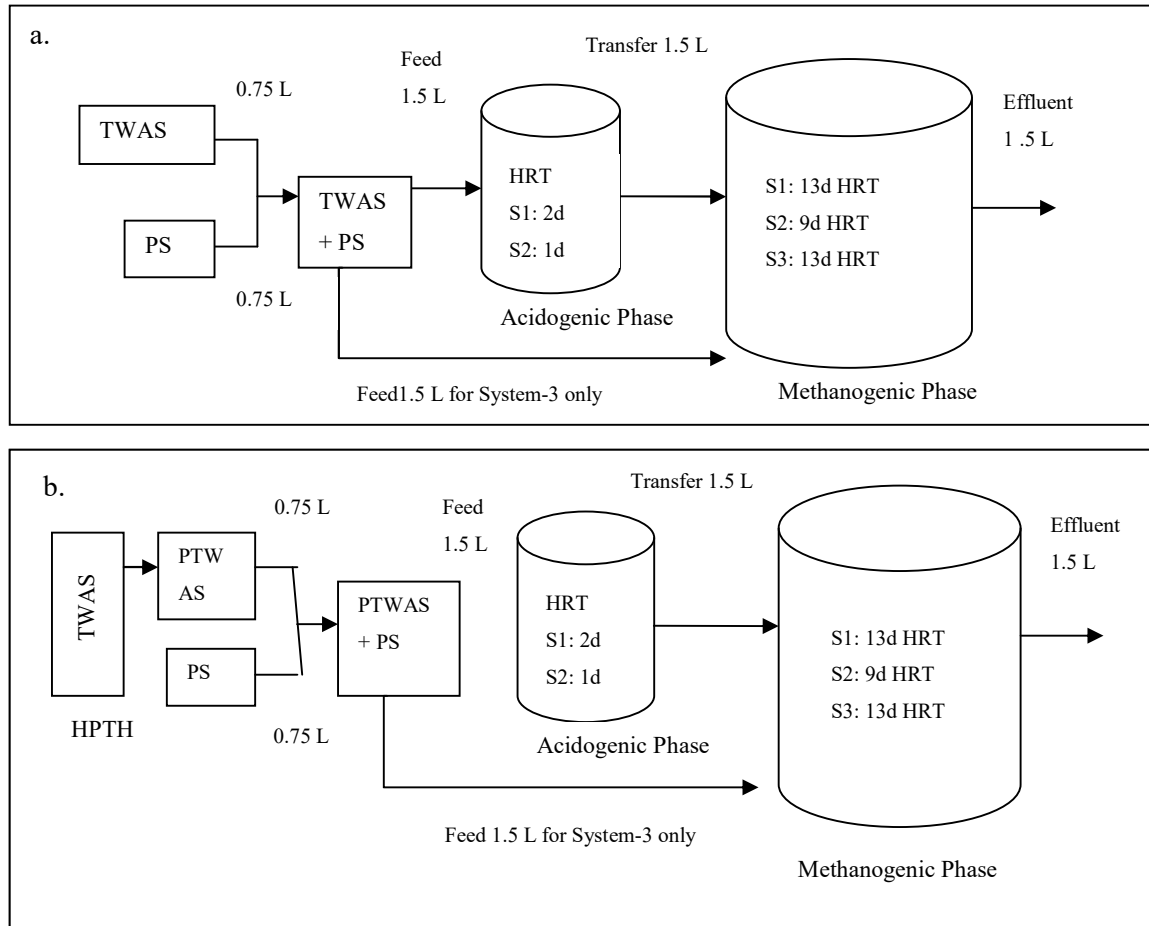

Figure 3.2: Schematic diagram of the process (a) control process, (b) Pretreated process.

Figure 3.2 displays the setup and configuration of the two stage digesters operated in all systems. Cylindrical digesters with total volumes of 22 L were used for the methanogenic phase while 5 L digesters were employed for the acidogenic phase. The working volume of the methanogenic phase digesters was 19.5 L in System-1 & System-2 and 13.5 L in System-3. The working volume for the acidogenic phase was 3L in System-1 and 1.5 L in System-2. The control system was fed with raw TWAS and raw PS (1:1 by volume ratio) and the pretreated system was fed with pretreated TWAS and raw PS (1:1 by volume ratio).

All four digesters were operated at a constant mesophilic temperature of $37\pm 1^\circ\text{C}$. The digesters were wrapped with a thermal water jacket made from plastic tubing. The heating water was continuously circulated through a water bath that was set at 38°C . The temperature inside each digester was monitored continuously by bi-metallic analog thermometers from Fisher Scientific (model no. B613105700RMD). Mixing in the digesters was provided by a Bodine® Model 0158 DC Gearmotor that was connected to a power converter. Each mixer had a rotational speed of 200 rpm.

Gas volume and gas composition were monitored daily. The gas volume was measured using a standard wet tip gas meter (<http://wettipgasmeter.com>) and the gas composition was analyzed by a gas chromatograph (Model SRI 310 C, SRI instrument, USA) equipped with a thermal conductivity detector. Helium gas was used as a carrier gas (3.5 ml/min). In the methanogenic digesters a 5 L Tedlar® gas sampling bag was connected between the gas sampling port and the gas meter to buffer pressure changes in the reactor during sludge feeding, wasting, and sample collection. In the acidogenic digester a gas line was attached to a 5 L Tedlar® gas sampling bag. The acidogenic phase was assumed to produce minimal gas because of its operating conditions and thus no flow meters were attached to the digesters. Each digester had two valves for feeding, wasting, and sampling purposes. The upper valves were used for feeding and the lower valves were used for wasting and sample collection. A peristaltic pump was used to feed, waste, and collect samples from the digesters. Gas lines connected to the gas flow meter were always kept closed with a valve to avoid suction of water during sampling and wasting.

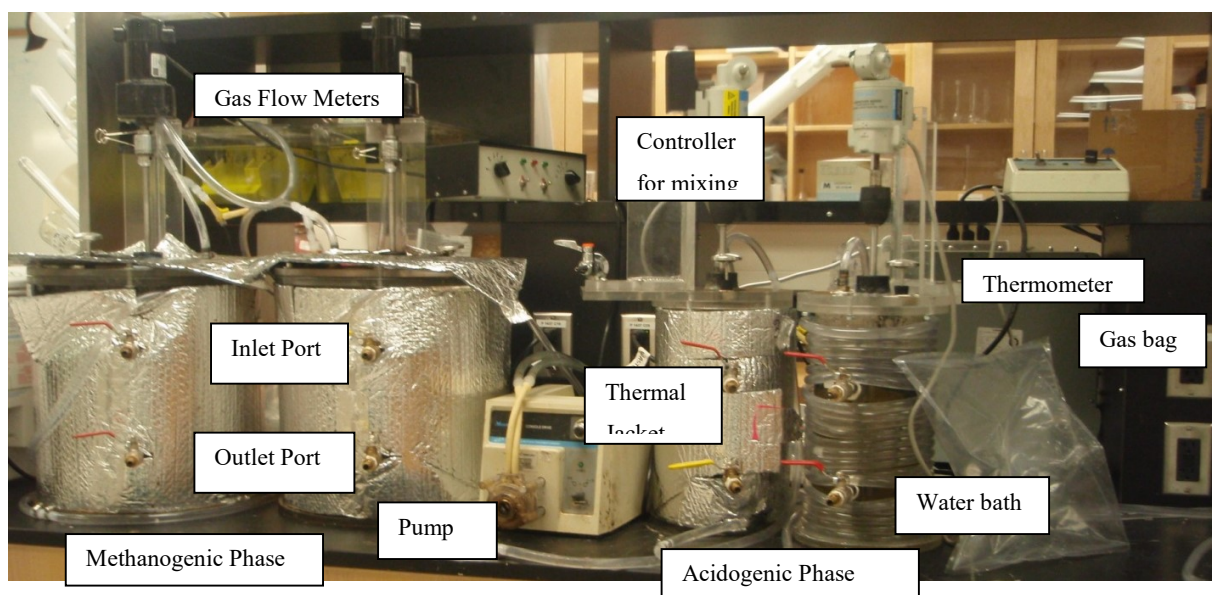

Figure 3.3: Two stage CSTR anaerobic digester setup.

3.3 Operation of Anaerobic Digesters

3.3.1 Start up of Digesters

All four anaerobic digesters (acidogenic and methanogenic phase) were operated from day 0 to 160 and only the methanogenic phase digesters were operated from day 160 to 210, as a single phased system. The bench scale digesters were batch fed daily at the same time using a pump. Initially, the digesters were washed out with nitrogen gas to confirm no air inside the digesters; and the gas bags were also partially filled with nitrogen gas to buffer the digester on the first day of operation. The seed sludge was collected from an anaerobic digester at the Kitchener Wastewater Treatment Plant. The acidogenic digesters (control and pretreated) were fed with 1.5 L of seed sludge and 1.5 L of feed (0.75 ml TWAS+ 0.75 ml PS for control and 0.75 ml PTWAS+ 0.75 ml Ps for the pretreated digester). On day 2, 75% of the methanogenic digesters (total working volume= 19.5 L) or, 15 L were filled up with seed sludge (stored in refrigerator at 4⁰C) and 1.5 L effluent was transferred from the acidogenic phase digester to the methanogenic digester. For the next three days this procedure was followed until the methanogenic digesters reached 19.5 L. Once the methanogenic digesters reached 19.5 L, a normal feed cycle was followed. In each feed cycle 1.5 L of effluent was discarded from the methanogenic digesters. Then, 1.5 L was collected from the acidogenic phase digesters to transfer into the methanogenic digesters. Finally, the acidogenic phase digesters were fed with raw sludge. The control digester was fed with a mixture of 0.75 ml TWAS & 0.75 ml PS whereas; the pretreated digester was fed with a mixture of 0.75 ml PTWAS & 0.75 ml PS. The amount fed was same for all the Systems and the working volumes of the digesters were altered to provide the desired HRT. The working volume of acidogenic phase digesters were 1.5 L and methanogenic phase were 13.5 L for System-2. System-3 was operated as a single phased system, and the working volume was 19.5 L in both digesters.

3.3.2 Project Schedule and Sampling Timeline

The operation of the anaerobic digesters started July 18, 2014 and finished February 27, 2015. The project timeline and major operations of the study relative to the starting time have been shown in Figure 3.4. Steady state for the methanogenic reactor in System-1 was obtained after 3 HRTs (39 days). The acidogenic reactor reached steady state just after a week as it was operated at a 2 day HRT. The steady state condition was confirmed by observing constant COD and SS concentrations with time. A similar approach was followed for System-2 & 3. The digesters were continuously operated and the later Systems reached steady state earlier and within 2 complete HRTs.

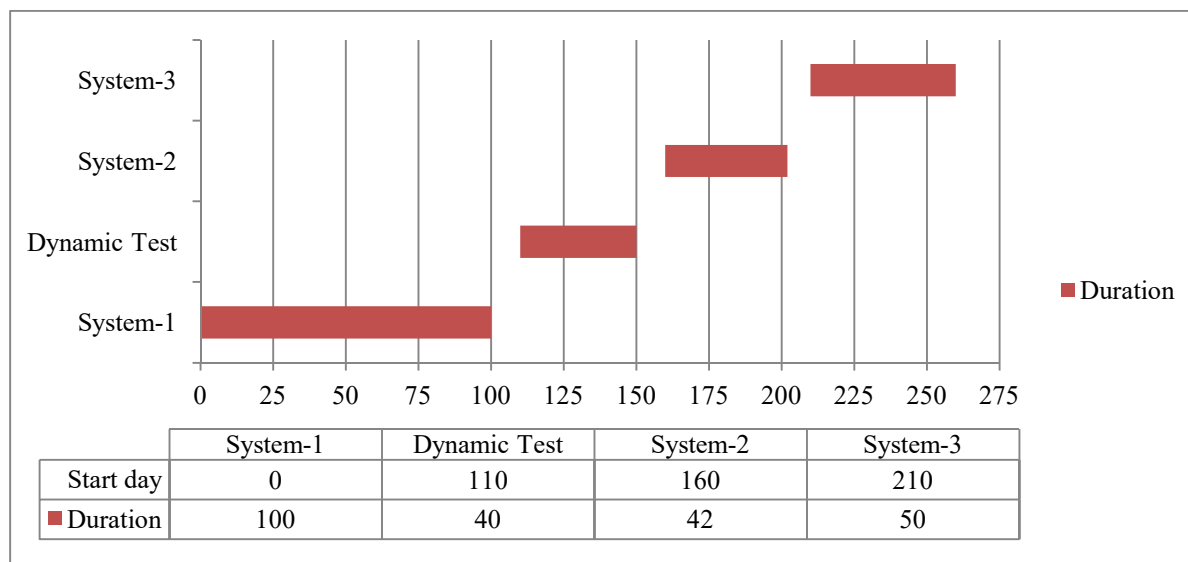

Figure 3.4: Project timeline of major operations.

After evaluating the performance of the two stage digesters in System-1, dynamic testing was conducted on the acidogenic phase digesters. During the dynamic tests, the methanogenic digesters were fed as single stage CSTRs and the effluents from the acidogenic phase digesters were discarded. During the dynamic tests, the acidogenic phase digesters were fed with TWAS and PTWAS. The dynamic tests were conducted to verify if HPTH pretreatment was generating any biodegradable COD that could be acidified to more readily biodegradable compounds, hence obtain reduced HRT. Upon completion of the dynamic tests System 2 testing was operated with the two stage configuration to evaluate the impact of a reduced HRT on system performance. System-3 testing was subsequently conducted to compare two stage performances with single stage operation. The sampling plan employed for the various Systems over the test period is shown in Table 3.1.

Table 3-1: Anaerobic digesters sampling timeline

	Days from start up	pH	TSS, VS S	TCOD, sCOD	VFA	Alkalinity	NH ₃ -N	TKN
System-1	0-45	Daily	Weekly	Weekly		Weekly		
	45-100	Daily	Weekly	Weekly	Weekly	Weekly	Weekly	Weekly
Dynamic Test	110-150	Daily	Daily	Daily	Daily	Daily	Daily	Daily
System-2	160-170	Daily	Weekly	Weekly	Weekly	Weekly		
	171-202	Daily	Weekly	Weekly	Weekly	Weekly	Weekly	Weekly
System-3	210-260	Daily	Weekly	Weekly	Weekly	Weekly	Weekly	Weekly

3.4 Sampling Protocol

The raw samples (PS, TWAS), pretreated samples (PTWAS) and the digested samples (acidogenic phase and methanogenic phase effluents) were analyzed, following the schedule described in Table-3.1. All the samples were analyzed in duplicate and with standards, where applicable. The methods of the laboratory tests and standards have been discussed in section 3.5. All test samples were analyzed immediately except VFA samples. Samples for VFA analysis were stored in the refrigerator at 4⁰ C after addition of 0.2 ml phosphoric acid (H₃PO₄) with 1.3 ml sample.

3.4.1 Pretreated Cycle and Collection

The pretreatment of TWAS was done as a batch procedure daily in 4 batches in order to generate 750 ml of feed daily for seven days. The excess pretreated samples were stored in the fridge at 4⁰ C in a container to feed on the weekends, and raw PTWAS sample analysis. To evaluate the effect of pretreatment on TWAS, laboratory analysis was done on the sample before and after pretreatment on the same day. The tests were repeated three times for each batch of sample that arrived within the two week time period. TSS, VSS, TCOD, sCOD, pH, alkalinity, ammonia and VFA were measured in each analysis.

3.4.2 Anaerobic Digester Monitoring

The effluents from the acidogenic phase and methanogenic phase digesters were collected daily to measure pH. The gas tips counted in the gas flow meter were also noted daily at the same time to obtain 24 hour gas production. Samples were tested for other parameters as described in section 3.3.2. Both liquid and gas samples were collected prior to feeding. The biogas composition was measured three times a week and the gas flow meters were calibrated, and leak testing of all four digesters were done once every week. Mixing was provided continuously for the entire experimental period and the temperature was monitored daily.

3.5 Sample Analysis

The physical and biochemical properties listed in Figure 3.5 were analyzed using conventional methods and according to the appropriate sections of Standard Methods for the Examination of Water and Wastewater (Eaton et al., 2005). Each sample was measured in duplicate, and standard samples were prepared for all the biochemical tests. Biogas was measured using gas flow meters and gas composition was also measured in duplicates for all four digesters.

Physical	Biochemical	Biodegradability
<ul style="list-style-type: none">•TSS•VSS	<ul style="list-style-type: none">•pH•Alkalinity•VFA•TCOD•sCOD•NH₃-N•TKN	<ul style="list-style-type: none">•BMP

Figure 3.5: Analytical methods used to determine effects of HPTH on TWAS.

3.5.1 Suspended Solids

The total suspended solids (TSS), and volatile suspended solids (VSS) were measured according to Standard Methods 2540 D and E (APHA 1998). Total suspended solids were measured by filtering dilute samples through a Whatman Glass Microfibre filter (934-AH) with a pore size of 1.5 µm that had been previously dried at 550°C. The filtered samples were then placed in an aluminum dish care with tongs. The filter was then dried at 105°C for at least one hour. The increase of weight in the filter paper represented TSS. Finally, the filter paper was combusted at 550°C for at least 45 minutes. The weight loss

in the ignition represented VSS. All the transportation of filtered samples inside the aluminum dishes was carried out using a covered container to avoid any loss of sample during transportation from one place to another.

3.5.2 TCOD

TCOD analysis was conducted according to Standard Method 5220 D (APHA, 1998). HACH vials (Range: 0-1500 mg COD /L) were used to measure chemical oxygen demand (COD). A series of diluted standard samples were prepared and measured to obtain a calibration curve. For analyzing the samples, a homogenizer was used for 30 seconds to mix 20 ml of the sample. The sample was then diluted to the appropriate factor and the diluted sample was again homogenized for 30 seconds. After that 2 ml of sample was added to each vial. HACH vials were used to measure chemical oxygen demand (COD). Three vials were used for each sample. For each test, a blank and standard vial was also prepared. The blank vial contained 2 ml of distilled water, the standard COD solution by HACH that has a COD value of 1000mg/L. The vials were then inverted 10 times before placing in the preheated HACH COD reactor for 2 hours at 150⁰C. The heater was preheated for 30 minutes and the temperature was confirmed using an analog thermometer. Once the vials were digested for 2 hours, they were allowed to cool down to room temperature before measuring. Once they were at room temperature all the vials were measured using a HACH DR/2000 Spectrophotometer.

3.5.3 sCOD

A volume of 50 ml of sample was collected in a centrifuge tube that was then centrifuged for 30 minutes. The supernatant was filtered through 0.45 µm membrane filters (Non-Sterile membrane filter, Cat. No. CA28148-584 Pall® Life Sciences, VWR, Canada). The filtered sample was diluted and added to the HACH COD vials as described in the TCOD section 3.5.2. Similar procedure was applied to determine the sCOD of samples.

3.5.4 Ammonia

Standard HACH vials were used to measure ammonia with a range of 0-50 ml NH₃-N. Centrifuged and filtered samples prepared for sCOD were collected and diluted for ammonia measurement. A volume of 0.1 ml of filtered sample was added to the vial, along with the Ammonia Salicylate and Ammonia Cyanurate Reagents. The vials was then capped tightly and shaken thoroughly to dissolve the reagents. For each test, a standard and blank vial was prepared. Once mixed, the vials were kept in the rack for 20

minutes to complete the reaction. After 20 minutes all the vials were measured with a HACH DR/2000 Spectrophotometer.

3.5.5 TKN

The TKN analysis method employed in this study was developed in the Environment Canada Wastewater Technology Center in Burlington, Ontario. It involved adding 1.5 ml of a digestion solution to 1 ml of the homogenized sample in a digestion flask. The digestion solution was prepared by first dissolving 40 g potassium sulfate and 2 ml selenium oxychloride in 250 ml sulfuric acid. This solution was then diluted by the addition of deionized water to reach a volume of 500 ml. After the addition of the digestion solution the sample was digested in a Bran and Luebbe BD-40 block digester at 220°C for 1.5 hours followed by digestion at 380°C for 2.5 hours. This digestion converted all the organic nitrogen to ammonia. The samples were allowed to cool down to room temperature overnight, diluted, and analyzed the next day using the Bran and Luebbe Auto Analyzer 3 to colorimetrically measure the concentration of ammonia in samples. In the Auto Analyzer, the ammonia in a sample was reacted with sodium hypochlorite, a sodium hydroxide buffer solution, and phenol to produce indophenol. Sodium nitroprusside present in the buffer reagent intensified the colour prior to colorimetric analysis at 660 nm.

3.5.6 VFA

The volatile fatty acid (VFAs) content of samples was quantified using gas chromatography (Model: Hewlett Packard HP 5890 Series II) equipped with a Nukol fused-silica capillary column and flame ionization detector (FID). Helium gas was used as a carrier gas. The filter samples from the sCOD analysis were utilized in this analysis, and the filtrate was acidified to pH 2 using 1 N phosphoric acid before GC-FID analyses. A 1.5 ml glass vial with septa cap (Sigma- Aldrich) was used to prepare the sample. A volume of 1.3 ml of filtered sample from sCOD analysis was added to the vial with 0.2 ml of phosphoric acid. The vial was shaken for 30 seconds using a shaker to ensure well mix.

To monitor the stability of the methanogenic phase digesters, the VFA to Alkalinity ratio was measured with a 4-point titration method, adapted from Buchauer, 1998. A volume of 3 ml of filtered sample prepared for sCOD analysis was diluted to make 50 ml of solution. The solution was titrated with 0.1 N sulfuric acid solution with constant mixing until pHs of 5, 4.3, and 4 were reached. The pH was measured with a pH Meter (Model 420A, Orion Research Inc., USA). The volume of acid required to reach each pH

end point was recorded. Finally, alkalinity and VFA concentration were calculated according to the equation provided by Buchauer, 1998.

3.5.7 pH

The pH values of all the digesters were measured daily with a pH Meter (Model 420A, Orion Research Inc., USA).

3.5.8 Gas Data

Gas volume and gas composition were monitored daily. The gas volume was measured using a standard wet tip gas meter (<http://wettipgasmeter.com>). The gas tip meters were checked daily by squeezing the gas bag and inserting gas inside the flow meter to count the tips. The gas composition was analyzed by a gas chromatograph (Model SRI 310 C, SRI instrument, USA) equipped with a thermal conductivity detector. Helium gas was used as carrier gas (3.5 ml/min). A gas sample was collected from the gas sampling line attached to the digesters with an air tight 100 ml syringe. Plastic septum was used to cover the tip of the syringe to avoid any loss of gas on the way from the digester to the gas chromatograph machine. The gas was injected slowly in the machine. Before each measurement, the machine was injected with 99.99% methane gas collected from a cylinder to confirm the stability of the machine and accuracy of the results.

3.6 BMP Test

The biochemical methane potential (BMP) test was conducted to evaluate the anaerobic biodegradability of different combinations of the raw and pretreated samples. In this study, 500 ml serum bottles were utilized to complete the test. Anaerobically digested sludge was collected from the Cambridge Wastewater Treatment Plant and used as inocula. HPTH pre-treatment was implemented on both sludges for this test.

Each bottle contained 225 ml of seed sludge and 25 ml feed sludge. For the blank, the bottle contained only 225 ml seed sludge, and no feed sludge was added. The bottles that contained only one type of feed sludge were filled with 25 ml of that type of feed sludge (i.e., TWAS, pTWAS, PS and pPS); the bottles that contained a combination of two feed sludges (i.e., PS + TWAS, pPS + pTWAS, PS + pTWAS and TWAS + pTWAS) were filled with 12.5 ml of each type of feed sludge. The thermal pretreatment was conducted as described in section 3.1. for both PS and TWAS, and digested in various combinations.

The bottles were initially filled with the seed sludge, and then purged with nitrogen gas (~1 min/bottle). The bottles were then sealed with septum and aluminum caps. They were incubated at 38 °C to let them degas, during which the gas was released from the bottles using a manometer. After the degassing was done, the bottles were filled with the feed sludge and returned to the incubator at 38 °C. Before placing them in the incubator, 5 ml samples were collected from each bottle to measure TCOD and sCOD. After that the gas production was measured daily with the manometer. The test continued for 16 days. The biogas composition was analyzed daily as described in section 3.5.8. To calculate the biodegradable fraction equation 2.3 was used.

3.7 Dynamic Test

The Dynamic test was designed to assess the enhancement of hydrolysis rate and fermentation of PTWAS on acidogenic phase environment. Acidogenic phase was assumed to accelerate the hydrolysis rate in order to reduce the overall HRT of the systems while generating more readily biodegradable compounds by fermentation that will help produce more methane in a later phase.

The first step of anaerobic digestion is hydrolysis and also known as the rate-limiting step. Pre-treatment's has been utilized to accelerate this process. The separation of two stages instead of one is believed to improve the hydrolysis rate and fermentation further depending on the characteristics of the feed sludge. One of the most common hydrolysis kinetics is a first-order relationship under constant pH and temperature (Batstone et al., 2002). However, the simplification of the hydrolysis process was found insufficient while describing the hydrolysis of particulate matter. As a result, literatures recommended more elaborate models to consider the readily and slowly biodegradable fractions of the sludge (Yasui et al., 2008; Ramirez et al., 2009).

The purpose of HPTH of the TWAS was to intensify the solubilisation of PCOD into simple sCOD in order to obtain readily biodegradable compounds and improve the hydrolysis and fermentation rate inside the acidogenic phase. A set of batch test was conducted on the acidogenic phase for TWAS and PTWAS to identify if the solubilised PTWAS was enhancing the hydrolysis rate further in order to produce more VFAs. The biodegradable particulate of sludge is typically used to estimate the hydrolysis rate constant. The particulate COD was calculated from Equation 3.1.

$$\text{PCOD} = \text{TCOD} - \text{sCOD} \quad (3.1)$$

Hydrolysis rate constants (K_1 and K_2) for the TWAS and PTWAS were determined by fitting a first-order model demonstrated in equation 3.2. The PCOD value was obtained from the batch experiments. A dual-

pathway first-order model in equation 3.6 was also fit to the PCOD data. Both models were compared to evaluate best fit data.

The single-pathway model for hydrolysis was

$$\frac{dP}{dt} = -K \times P \quad (3.2)$$

Integrating equation 2.4 yields:

$$P = P_0 \times e^{-K \times t} \quad (3.3)$$

The dual-pathway model for hydrolysis was:

$$\frac{dp_r}{dt} = -K \times P_r \quad (3.4)$$

$$\frac{dp_s}{dt} = -K \times P_s \quad (3.5)$$

Integrating and adding equation 2.6 and 2.7 yields:

$$P = P_{0s} \times e^{-K_s \times t} + P_{0r} \times e^{-K_r \times t} \quad (3.6)$$

$$P = P_{0s} + P_{0r} \quad (3.7)$$

$$P = P_{0s} \times e^{-K_s \times t} + (P_0 - P_{0s}) \times e^{-K_r \times t} \quad (3.8)$$

Where,

P = biodegradable particulate COD at time t, in mg/L;

P₀ = initial biodegradable particulate COD, in mg/L;

P_{0s} = initial slowly biodegradable particulate COD, in mg/L;

P_{0r} = initial rapidly biodegradable particulate COD, in mg/L;

K = first-order kinetic constant, in day;

K_s = first-order kinetic constant for slowly biodegradable COD, in day;

K_r = first-order kinetic constant for rapidly biodegradable COD, in day;

t = time, in day.

A non-linear regression was performed using the MS Excel solver function to estimate the first-order coefficients of the hydrolysis rate as well as the initial slowly and rapidly biodegradable organic matter through fitting equation (3.8) to the biodegradable particulate COD degradation data. The root mean square error (RMSE) was the minimizing function for the model curve fitting and as a result the lower value of RMSE represents better fit.

Chapter 4 - Results and Discussion

The characteristics of the raw sludges, the thermal pretreatment product and the digestion results for various conditions are discussed in this section. The results and discussion are divided in five sections. Section-4.1 & 4.2 focus on results obtained from the three different Systems of study. In section 3.1 the characteristics of the raw TWAS and PS sample are discussed. The data was used in the later sections to compare the effects of thermal pretreatment with the anaerobic digester results. Section 3.2 will demonstrate the effect of pretreatment on TWAS and the average value of PTWAS and PS were used as the feed data to the pretreated anaerobic digester. In sections 3.3 & 3.4 a comparison between the control and pretreated digesters is presented. The control digester was fed with raw TWAS and PS and the pretreated digester was fed with pretreated TWAS and PS. Section 3.3 will describe the advantages and disadvantages of the acidogenic stage of anaerobic digesters and hence only Systems 1 & 2 are discussed. Section 3.4 compares the methanogenic stage of System-1 & 2 and the single stage of System-3. Finally, Section 3.5 discusses the overall effect of thermal pretreatment combined with two stage CSTR process and overall removal efficiencies along with achievements for all three Systems.

4.1 Sample Characteristics

The physical, biochemical and biological properties of the raw TWAS and PS are discussed in this section. The data in this section will provide a platform for comparison with the effluents from the pretreatment and the anaerobic digesters that are described in later sections. A summary of the lab test results for the TWAS and PS streams for all three Systems are presented in Tables 4.1 and 4.2 respectively. The samples were characterized with respect to suspended solids, COD, ammonia, alkalinity, pH, and TVFAs. The ratios of some parameters were tested to verify the presence of biodegradable contents, solubilisation and the buffering capacity of the samples. The results are presented as averages and standard deviations for all parameters.

Table 4-1: Characteristics of Raw PS samples

Parameter	Unit	System-1	System-2	System-3	Reference
TSS	mg/L	53000±4100 (20,3)	46500±2000 (12,3)	48700±3700 (12,3)	30500
VSS	mg/L	45300±2100 (20,3)	37000±3100 (12,3)	39700±2600 (12,3)	23400
VSS/TSS	%	86	80	81	77
TCOD	mg/L	69700±2400 (20,2)	55500±3200 (12,3)	59500±4500 (12,3)	56900
sCOD	mg/L	3900±450 (20,2)	3050±370 (12,3)	4140±720 (12,3)	3100
sCOD/TCOD	%	6	6	7	5
NH ₃	mg N/L	100±17 (12,2)	105±6 (8,2)	160±8 (8,2)	61
TKN	mg N/L	3750±100 (8,1)	3772±70 (8,1)	3400±240 (8,1)	
TVFA ^a	mg COD/L	150±10 (12,3)	165±15 (8,2)	185±10(8,2)	
Alkalinity	mg as CaCO ₃ /L	900±30 (12,1)	750 ±60(8,1)	800±50 (8,1)	
TVFA/sCOD	%	4.25	4.99	4.63	
pH	N/A	5.6±.12 (120,1)	5.3±.23 (30,1)	5.5±.15 (40,1)	5.6

^aTVFA= acetic acid + propionic acid+ butyric acid+ iso butyric acid + valeric acid +iso valeric acid

Bracketed values in each column indicates number of samples and their replicates

Table 4-2: Characteristics of the Raw TWAS samples

Parameter	Unit	System-1	System-2	System-3	Reference
TSS	mg/L	36000±3200 (20,3)	42500±2300 (12,3)	43900±2840 (12,3)	59000
VSS	mg/L	27600±3100 (20,3)	36000±3400 (12,3)	35700±1960 (12,3)	47200
VSS/TSS	%	77	85	81	80
TCOD	mg/L	45600±4000 (20,2)	53500±4000 (12,3)	53800±3800 (12,3)	79300
sCOD	mg/L	3500±600 (20,2)	3300±400 (12,3)	4040±420 (12,3)	300
sCOD/TCOD	%	8	6	8	0.4
NH ₃	mg N/L	140±20 (12,2)	160±30 (8,2)	250±15 (8,2)	190
TKN	mg N/L	2300±140 (8,1)	2340±180 (8,1)	2000±100 (8,1)	
TVFA	mg COD/L	230±30 (12,3)	250±45 (8,2)	260±40 (8,2)	
Alkalinity	mg as CaCO ₃ /L	1800±100 (12,1)	1600±70 (8,1)	1750±35 (8,1)	
TVFA/Alkalinity	N/A	0.15	0.16	0.14	
TVFA/sCOD	%	6.52	7.75	6.84	
pH	N/A	6.3±.13 (120,1)	6.1±.15 (40,1)	6.3±.12 (40,1)	6.4

^aTVFA= acetic acid + propionic acid+ butyric acid+ iso butyric acid + valeric acid +iso valeric acid

Bracketed values indicates number of samples and their replicates

The results presented in Table-4.1 & 4.2 spanned three seasons of wastewater treatment plant operation and as a result seasonal variations were observed in the data. The seasonal variations for all parameters were within 20% except for ammonia in the PS, which had a higher value in System-3. The ammonia in

the PS was almost two times higher in System-3 compared to Systems 1 & 2. The reference values were obtained from Metcalf and Eddy, 2003 for typical municipal primary and secondary sludge. All the parameters were consistent with the reference values except the sCOD value of the TWAS. The average sCOD/TCOD ratio of TWAS was 7% in the samples whereas; it was only 0.4% in the reference.

However, the sCOD/TCOD ratio was consistent for the PS samples.

The TSS and VSS concentrations of the TWAS and the PS were compared along with the VSS/TSS ratio as indicators of the organic matter in the sludges. Compared to the TWAS sample the PS sample had 17% higher TSS and 19% higher VSS on an average of all Systems. On average the TWAS contained 4% TSS and the PS contained approximately 5% TSS. The TSS/VSS ratio of the TWAS was 77-85% and PS was 81-86%, indicating presence of high and similar amount of organic content. The seasonal variation observed for TSS and VSS parameters were within 14% for both samples. These variations will impact the results presented in later sections. Data will be normalized and only ratios will be used to compare the results among Systems.

The biochemical properties such as COD, ammonia, TKN, alkalinity and TVFA were measured to characterize the initial extent of COD solubilisation, nitrogen speciation and buffer capacity of the samples that were used in the subsequent tests. In terms of TCOD, the average values for the PS were 20% higher than the TWAS. By contrast, the sCOD was similar in both TWAS and PS. The sCOD concentrations in the TWAS were consistently low and constituted approximately 7.3% of the TCOD. In this study, thermal pretreatment was employed to increase the sCOD, which would help to produce more methane and pretreatment was done only for the TWAS. Previous studies have found minimal effect of thermal hydrolysis on the PS (Phothilangka et al., 2008) as it contains more lipids and very low amount of cells that could be ruptured by thermal pretreatment (Parker, 2015)

The concentrations of TVFA indicate the fermented fraction of COD in the samples and is an indication of the availability of substrates for the methanogenesis process. The TVFA of the TWAS was 46% higher compared to the PS on an average of three Systems. The TVFA concentrations were within typical limits as indicated in Metcalf and Eddy (2003). The TVFA/sCOD ratio was only 7.1% in PS and 4.6% in TWAS, which implies there was very low amount of TVFA accumulation in the samples. The sCOD contributed only 6% of TCOD in the PS sample and 7.3% of TCOD in the TWAS sample.

Ammonia has the potential to inhibit anaerobic systems if the threshold value (3000 mg/L) is exceeded. Hence, it was considered important to know the initial ammonia value in the raw sludge to compare the

increase in later sections and also to identify if there was any significant amount of organic matter solubilisation during sludge handling process. The ammonia concentrations were higher (almost 50 %) in the TWAS as compared to the PS in all Systems. The presence of ammonia influenced the pH values, as the pH was high in the TWAS compared to the PS. The pH of the PS was slightly more acidic than the TWAS.

Alkalinity is required to maintain the stability of the anaerobic digester as it can buffer pH fluctuations if accumulation of TVFAs occurs. The alkalinity in the TWAS sample was more than two times higher than the PS sample. However, both of them had high alkalinity values as compared to the reference value. High alkalinity value is required to maintain the stability of anaerobic digesters. System-1 & 2 have two stage anaerobic digestion systems and accumulation of TVFAs will occur in the acidogenic phase with shorter HRT to be utilized by methanogenic System organisms. To maintain the stability of the methanogenic digesters, the high alkalinities will be required.

4.1.1 BMP Tests

BMP tests were conducted to characterize the anaerobic biodegradability of the substrates. Figure 4.1 presents the BMP test results for the TWAS, PS, PTWAS and pPS samples in terms of cumulative methane production over a period of 16 days. The plan that was employed to conduct the BMP test and detailed results are summarized in Appendix-A. Pre treatment of the TWAS increased the methane production 34%, whereas the pretreatment of the PS only increased methane production by 6%. From Figure 4.1 it is obvious that pretreatment affected CH_4 from TWAS more than PS.

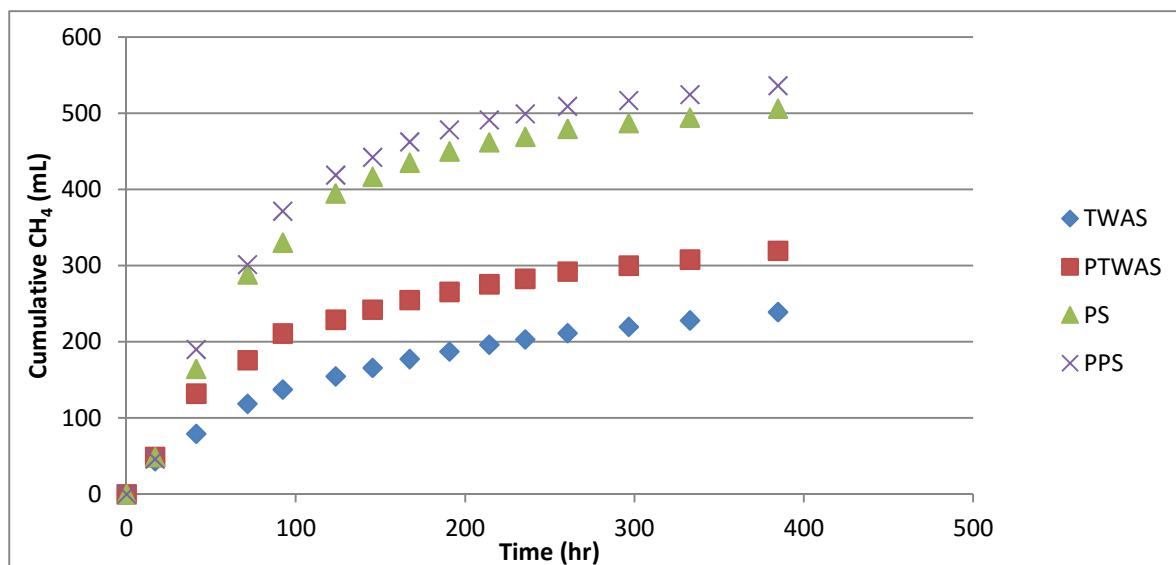

Figure 4.1: BMP test results of raw samples.

The BMP data was normalized for all the substrate with respect to TCOD added. This was done to compare the results with respect to the same platform. Figure 4.2 shows the methane yield in terms of substrate TCOD added to the test bottles. Various combinations of the TWAS, PS, with or without pretreatment were employed to achieve the best combination for maximum methane production. The methane yield of the PS was 10.8 L CH₄/g TCOD added, and for the pPS was 11.4 L CH₄/g TCOD added (Figure 4.2). Hence, the methane yield of the pPS was only 5% higher than the methane yield of PS. As a result, the pretreatment of the PS was excluded in subsequent experiments. From Figure 4.2 it can be seen that the methane yield was 2.3 times higher in the PS compared to the TWAS. Among the four sludge blends, the PS and PTWAS blend showed the highest methane yield of 9.6 L CH₄/g TCOD added. This yield was 17% higher compared to the PS and TWAS blend. Again the difference between the pPs+PTWAS combination and the PS+PTWAS combination was 6%. Hence, to minimize required energy and costs, only the TWAS of mixed sludge feeds for AD were subsequently pretreated.

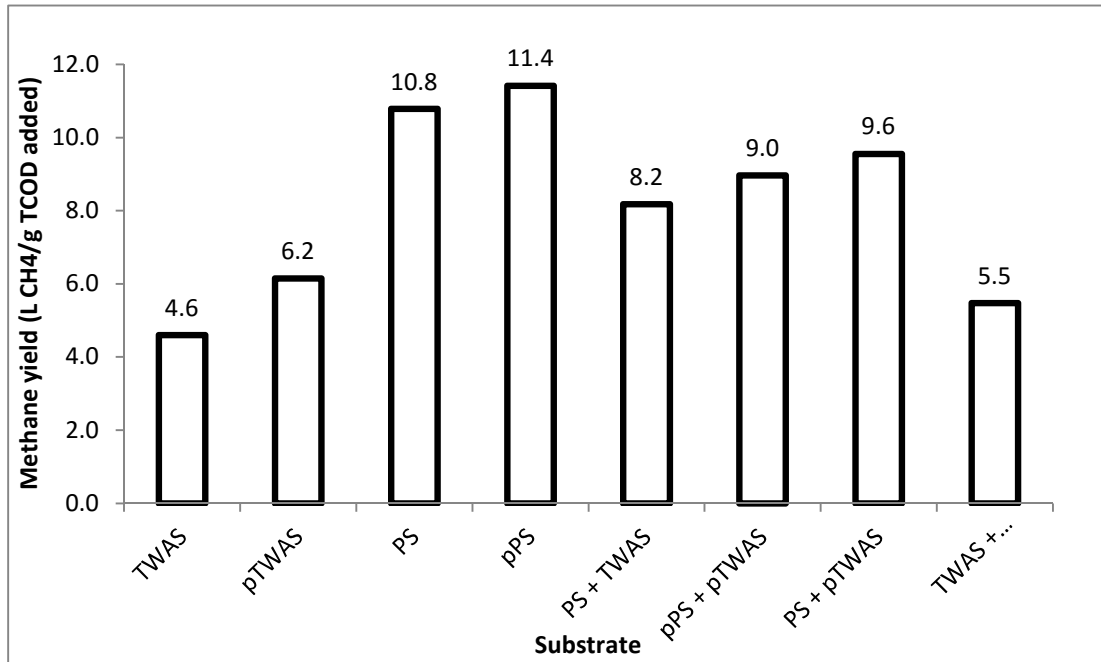

Figure 4.2: Methane yield obtained in BMP test.

An estimate of the biodegradable fraction of the sludge particulate matter was required for the subsequent estimation of the hydrolysis kinetic parameters. Hence, the BMP test results were used to estimate the biodegradable fraction of the organic matter. Table -4.3 presents methane production and TCOD added data for the two runs of the BMP tests. The standard deviation was less than 3% and as a result not shown in the calculations. The methane volume produced was calculated for STP conditions for mass balance calculations.

Table 4-3: Biodegradability determination of raw sludge

Parameters	Inocula		TWAS		PTWAS		PS	
	Run 1	Run 2	Run 1	Run 2	Run 1	Run 2	Run 1	Run 2
CH4 (ml)	119.00	120.00	243.00	239.00	327.00	312.00	465.00	455.00
TCOD in (g/L)	21.18	19.13	47.54	47.30	49.52	49.52	55.43	55.23
MASS								
CH4 (g COD)	0.34	0.34	0.69	0.68	0.93	0.89	1.33	1.30
TCOD in (g)	4.77	4.30	5.95	5.49	6.00	5.54	6.15	5.69
Biodegradability			0.30	0.31	0.48	0.44	0.72	0.69
Average Biodegradability			0.30		0.46		0.70	

The biodegradable fraction of the sludge was determined using Equation 2.3. The net values of the total influent COD and methane production of raw sludge was calculated by subtracting the influent COD and methane production generated in the control bottles. To obtain the mass of CH₄ as g COD at STP, produced methane in each bottle was divided by 350 (ml CH₄ / g COD at STP). Finally, the mass of methane at STP was divided by the total influent COD mass of each bottles to determine the biodegradable fraction of the raw sludge. The biodegradable fractions of the TWAS, PTWAS and PS were estimated as 30%, 46% and 70% respectively. The ultimate biodegradability reported for PS by Parkin and Owen (1986) was 69% and was 30-50% for WAS (Parker, 2005). Thus, the biodegradable fractions obtained from the BMP test of this study were comparable with literature findings.

4.2 Effects of Pretreatment

This section presents the results from pretreatment of the TWAS sample. The results obtained before and after pretreatment of the TWAS are presented. Although, solubilisation of particulate matter was considered as the main parameter to assess the impact of the pretreatment, the changes in other parameters (TCOD, TSS, VSS, NH₃, TKN, TVFA, pH, Alkalinity) through pretreatment will also be discussed. BMP test result on TWAS and PTWAS will be presented to characterize the impact of pretreating TWAS on anaerobic biodegradability. The results of the three Systems were compared to assess if there were any impacts of seasonality on the pretreatment performance.

4.2.1 COD Concentrations and Sludge Solubilisation

The literature has shown that HPTH increases sludge solubilisation, which enhances subsequent microbial growth and metabolic activities. Pretreatment causes the rupture of microbial cell wall of the TWAS, which releases EPS (carbohydrates, proteins, lipids) and VFAs. The release of EPS and VFAs might be the reason of increase of sCOD (Dhar et al., 2012). Figure 4.3 shows average COD concentrations before and after pretreatment for the three Systems. PCOD was calculated by subtracting sCOD from TCOD for each measurement. In this section, COD solubilisation has been discussed to evaluate the effect of pretreatment on particulate organic matter. The COD solubilisation ratio was defined as the fraction of the initial TCOD that was present in the soluble form. Values from Figure 4.3 along with equation 2.2 were employed to calculate the COD solubilisation.

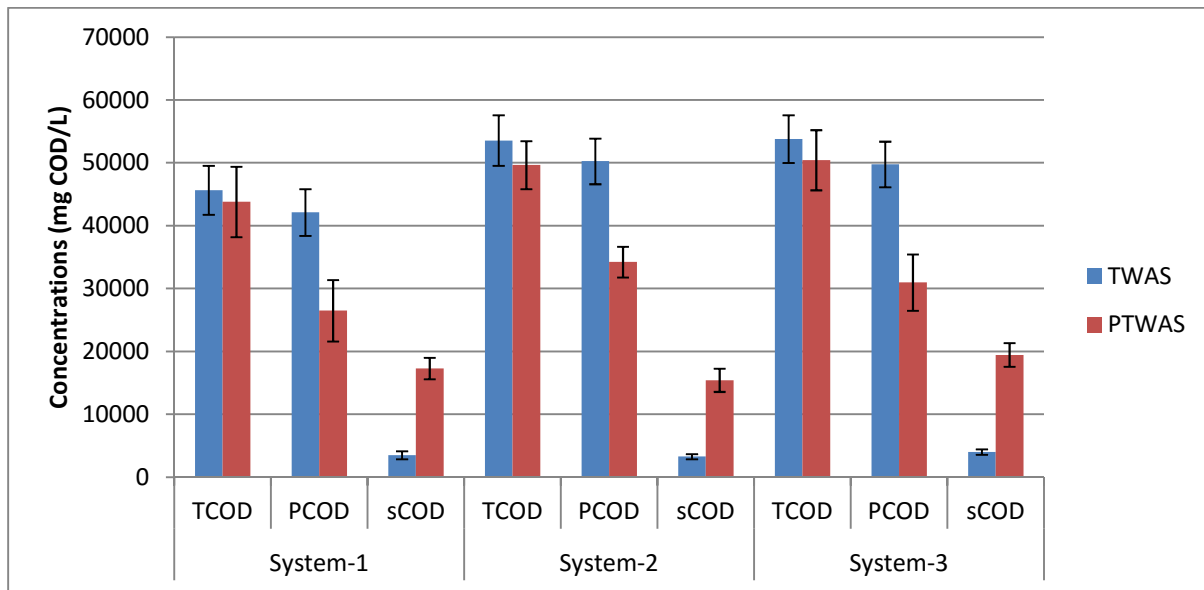

Figure 4.3: Average COD concentrations before and after pretreatment of TWAS.

COD solubilisation is an indicator of pre-treatment performance and an increase of COD solubilisation is often employed as an indicator of improved efficiency of subsequent anaerobic digestion. Figure 4.4 shows the solubilisation of the TWAS before and after pretreatment. The values of COD solubilisation obtained by employing equation 2.2 for the TWAS increased by 24 to 33% through pretreatment. The solubilisation range reported in the literature (section 2.1.2) was 28 to 45% and hence the solubilisation observed in this study was comparable to previous findings. Sludge solubilisation as a result of pretreatment is a function of sludge type, sludge age, type of pretreatment, pretreatment intensity and duration. The temperatures employed in previous studies (section 2.1.2) have ranged from 150 to 170 °C

and the pore diameter of the filters (0.45 to 1.6 μm) through which the soluble COD was measured have differed. Moreover, the pressure, duration of pretreatment and mode of operation also differed among the referenced studies. Therefore, a direct comparison between the COD solubilisation values measured in this project was deemed to be inappropriate. However, compared to other studies of sludge solubilisation those found in this experiment were within the range previously reported. The increase of COD solubilisation was expected to enhance the hydrolysis rate and improve acidogenic performance in the acid phase reactors by producing more fermentable products.

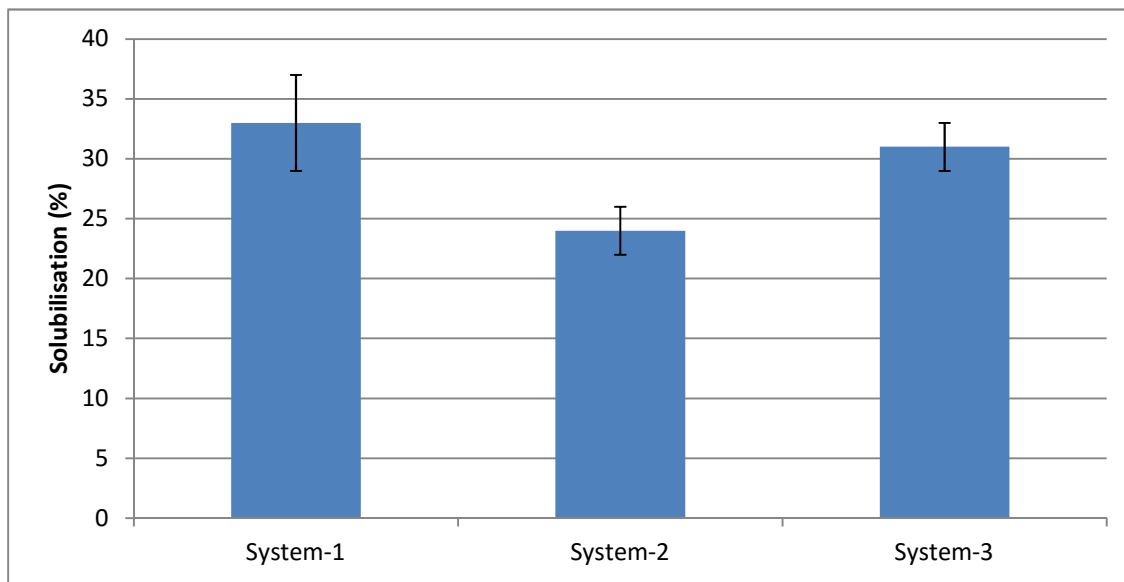

Figure 4.4: COD Solubilisation in all Systems.

A reduction in TCOD concentration through pretreatment indicates removal of organic matter. The TCOD was expected to remain the same before and after pretreatment (Morgan-Sagasume et al., 2010, Dhar et al., 2012, Burger and Parker, 2013). The resulted revealed a small variance (less than 10%) was found in TCOD value after pretreatment which was deemed to be insignificant. Thus, thermal pretreatment conserved the TCOD through pretreatment process.

4.2.2 Suspended Solids

The suspended solids concentrations were monitored throughout the operation to characterize the impact of PT on particulates. ISS for each measurement was calculated from the difference of TSS and VSS measurements. Figure 4.5 shows the average concentrations of TSS, VSS and ISS for all three systems during pretreatment. From the graphs it was concluded that the inorganic portion of suspended solids

remained unchanged through PT. A reduction of TSS and VSS values was however observed due to thermal pretreatment of 28% and 34% respectively (combined in all Systems). The reduction of ISS was only 3% and was not statistically significant. Thus it was concluded that no solubilisation of inorganic particulate matter took place.

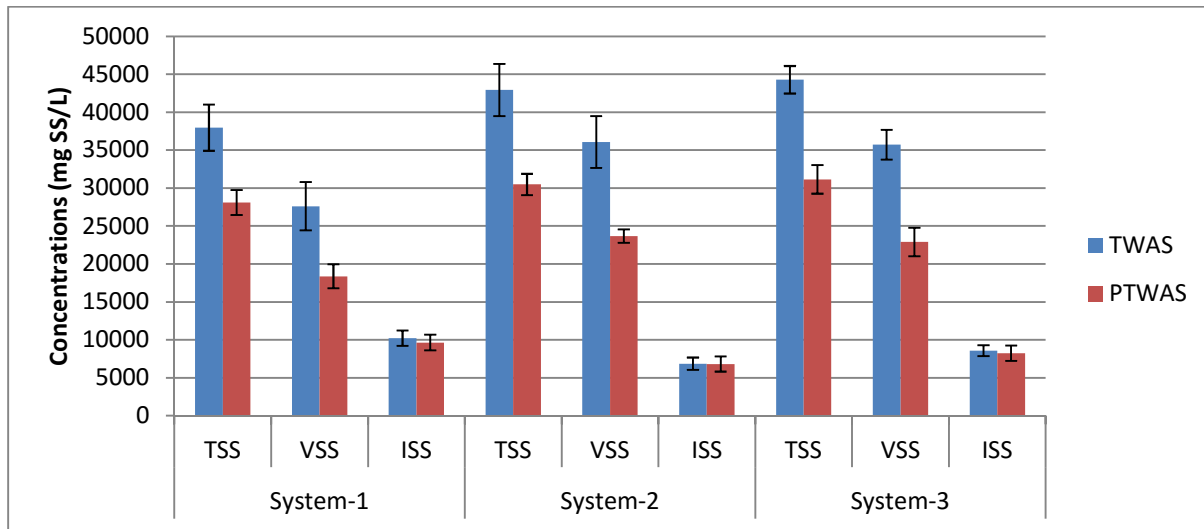

Figure 4.5: Comparison of suspended solids during pretreatment.

Morgan-Sagasume et al. (2010) and Burger G. (2012) employed equation 3.2.1.1 to calculate TSS reduction.

$$\text{TSS decrease (\%)} = ((\text{TSS}_i - \text{TSS}_f) / \text{TSS}_i) * 100 \% \quad (3.2.1.1)$$

In this equation TSS_i and TSS_f are the TSS concentrations obtained before and after pretreatment.

The average TSS decrease for each system was calculated and the average of the three systems was compared with the literature value. The average decrease in TSS concentration due to pretreatment in a study of the CAMBI™ pretreatment technology was 20-30% (Morgan-Sagasume et al., 2010). Thus, the 28% TSS decrease found in this study was within the range of literature values.

The VSS to TSS ratio indicates mineralization of the particulate matter as a result of pretreatment. However, if VSS is solubilised and no change is observed in VSS then this ratio can change without any mineralization occurring. In this study the VSS/TSS ratio was calculated for the average TSS and VSS values of each System. The average VSS/TSS ratio before and after pretreatment was $79 \pm 15\%$ and $72 \pm 8\%$, respectively. Thus, the decrease in the VSS/TSS ratio found was only 7% across all three Systems

and was statistically insignificant. Bougrier et al. (2008) and Burger (2012) reported 9% and 10% decreases in the VSS/TSS ratio of a sludge that was pretreated at 150 °C. Therefore, the ratio found from this study was comparable to the findings of literature mentioned above. Thus, it was concluded that no mineralization occurred during pretreatment and only solubilisation took place to convert a PCOD to sCOD.

4.2.3 Other Parameters

The effect of pretreatment on ammonia, VFA, alkalinity and pH were measured to obtain additional insight into its impact on the sludge. Table-4.4 presents the values for these parameters before and after PT. The ratio of TVFA to sCOD and ammonia to TKN was also presented to show their contribution in the sludge. The rationale for monitoring these parameters is subsequently discussed.

Table 4-4: Impact of PT on additional parameters

Parameter	Unit	System-1		System-2		System-3	
		Before PT	After PT	Before PT	After PT	Before PT	After PT
TKN	mg N/L	2130±150	2190±18 0	2340±178	2530±19 0	1990±10 0	2090±14 0
NH ₃	mg N/L	100±17	140±26	160±27	195±14	250±14	315±45
TVFA	mg COD/L	230±34	310±29	250±45	325±23	260±40	400±38
TVFA/sCOD	%	7	2	8	2	6	2
NH ₃ / TKN	%	5	6	7	8	13	15
Alkalinity	mg as CaCO ₃ /L	1800±100	2050±11 0	1600±70	2150±78	1750±35	1950±23
pH	N/A	6.3±.15	5.9±.32	6.1±.15	5.8±.12	6.3±.12	5.9±.34

As pretreatment is expected to rupture microbial cell walls and release proteins from organic nitrogen; there is the possibility of an increase in ammonia after pretreatment. Some studies have found no significant change of ammonia after pretreatment, and hence no mineralization of organic nitrogen (Burger and Parker, 2013). However, Bougrier et al. (2008) and Donoso-Bravo et al. (2010) reported that HPTH pretreatment slightly increased the ammonia concentration. This could happen due to some

mineralization of organic nitrogen to release ammonia. The results presented in Table- 4.4 indicate an increase of ammonia in all three Systems that was not statistically significant considering the error bars. Also, the ammonia varied from 5-15% of TKN before and after pretreatment. As a fraction of TKN the increase of ammonia through pretreatment was less than 2% in all three Systems. Hence the results indicate no significant mineralization of organic nitrogen occurred as a result of pre-treatment.

A change in TVFA was believed to be indicative of fermentation that may have happened through pretreatment. As pretreatment is assumed to be a hydrolysis step not much fermentation was expected. A 30% increase in TVFA through PT was observed as compared to the raw TWAS. Similar to the ammonia results the TVFA as a fraction of sCOD was only 2 % which was deemed to be negligible. Hence, minimal fermentation took place through pretreatment.

The pH was measured in the raw samples throughout the project to confirm the stability of the digesters. The pH remained relatively constant throughout all Systems with a slight decline. Table-3 shows the decreased pH of the TWAS from an average of 6.2 to 5.8. The slight decline in pH after pretreatment could be due to the increase in TVFA. The pH decrease was expected as it has been shown that HPTH pretreatment produces volatile fatty acids (Morgan-Sagasume et al., 2012).

To conclude, the TWAS COD was substantially solubilised through the HPTH pretreatment. Moreover, particulate organic matters were preferentially solubilised and negligible solubilisation of inorganic particulates was observed. The results obtained in this study indicate that the organics were solubilised rather than mineralized and were comparable to literature findings. The nitrogen species results indicated that proteins were solubilised rather than mineralized when compared as a fraction of TKN.

4.3 Acidogenic Phase Performance

System-1 and System-2 were operated as two stage CSTR anaerobic processes with different HRTs. The acid phase HRT for System-1 was 2 days whereas; it was 1 day for System-2. Both continuous and batch tests were performed on the acidogenic phase of the systems. In the continuous systems, the control digester was fed with a mixture of TWAS and PS with a 50:50 volumetric ratio whereas; the pretreated digester was fed with a mixture of PTWAS and PS at the same volumetric ratio. In the batch test the digesters were fed with only TWAS or PTWAS and no PS was added. The batch tests were dynamic and were conducted to determine the rate of hydrolysis and fermentation and will be discussed in section 4.3.2. In section 4.1.1, the biodegradable fraction of raw sludge was calculated through BMP tests and

PTWAS ($i_b = 46\%$) had a 16% higher biodegradable fraction compared to TWAS ($i_b = 30\%$). This section will discuss the results obtained from lab tests to assess if the higher biodegradable fraction generated as a result of HPTH pretreatment was acidified in this stage.

4.3.1 Steady State Results

The purpose of the acidogenic reactor was to acidify the substrate and thus improve the performance of the methanogenic reactor. The control digester was fed with raw sludge (PS & TWAS) only whereas; the pretreated digesters fed included pretreated TWAS along with PS. The feed values employed in this section were obtained from the average of PS and TWAS concentrations for the control digester and the average of PS and PTWAS for the pretreated digester. The PTWAS contained more soluble compounds (COD solubilisation 25 to 34%) compared to the TWAS and it was hypothesized it may be possible to reduce the HRT in this stage because hydrolysis had already been accomplished in the pretreatment stage.

4.3.1.1 pH and Alkalinity

In any AD stability is an important factor and pH is one of the most sensitive operating parameters because each microorganism has their own pH range to consume substrates. Yu and Fang, 2002; Kim et al., 2003, reported pH values ranging between 5.5 and 6.5 were optimum for hydrolytic and acidogenic microbes. As described in section 2.2.3, some prior studies controlled the pH of acidogenic digester by chemical addition to ensure acidification. However, in the continuous section of this current study, no pH adjustment was required for any digester. The pH profiles of the systems in the acidogenic digesters of two-stage AD are shown in Figure 4.6. The average effluent pH values for System-1 in the control and pretreated digesters were 5.53 ± 0.2 and 5.56 ± 0.15 respectively and the average effluent pH values for System-2 in the control and pretreated digesters were 5.4 ± 0.10 and 5.6 ± 0.10 respectively. The acid phase digesters were designed to separate the acidogenic microorganisms and that target was achieved as was observed by the high TVFA to alkalinity ratio values that were within a range of 2.2-2.8 in the Systems. To conclude, the pH of both digesters was within the optimum range of optimum acidogenic range as mentioned earlier.

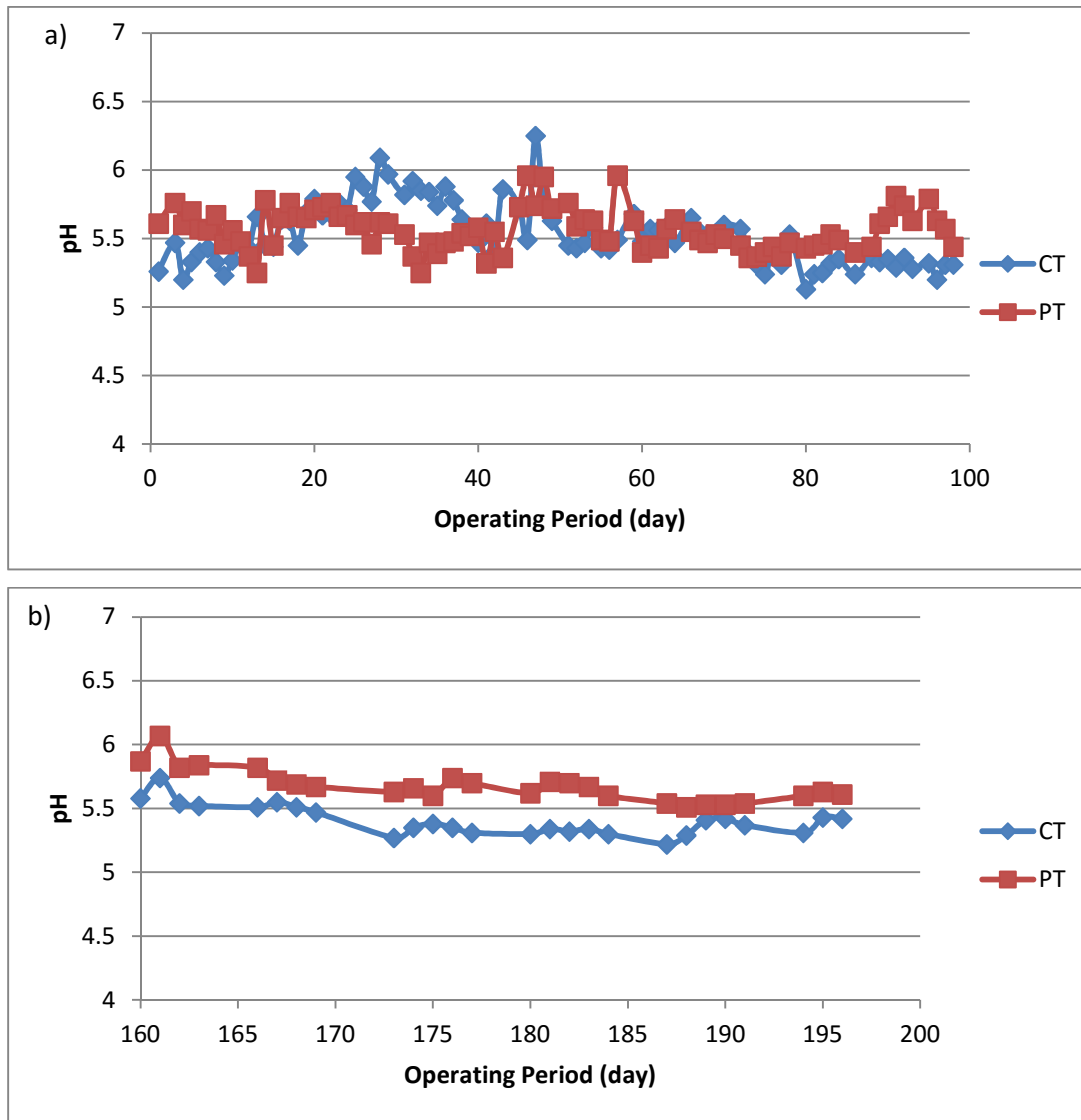

Figure 4.6: pH in acidogenic digesters a) System-1 and b) System-2.

4.3.1.2 TCOD Removal

In acid phase digesters, hydrolytic and acidogenic microorganisms are expected to dominate as their growth rate can be expected to be about ten times faster than methanogens (Ventura et al., 2014). If TCOD removal was observed it would indicate methane production and hence the activity of methanogenic bacteria which was not expected in the acidogenic phase. Hence COD concentrations were examined to assess whether there was significant methanogenesis. Figure 4.7 presents the COD and suspended solids concentrations in the Systems. In System-1, the average TCOD concentration decreased

from 58200mg/L to 52470 mg/L in the control digester, which suggested a 10% TCOD removal and the TCOD decreased from 57500 mg/L to 54600 mg/L, which suggested a removal efficiency of 5 % in the pretreated digester. Considering the error bars, the differences in removal efficiencies were less than 10% were statistically insignificant. In System-2 with a 1 day HRT the TCOD removal was again less than 10% in both digesters and as mentioned for System-1 this removal percentage was deemed to be negligible. The TCOD concentrations in System-2 decreased from 53000 mg/L to 49900 mg/L in the control digester which yielded a removal efficiency of 6% and it decreased from 52700 mg/L to 48400 mg/L in the pretreated digester which has a removal efficiency of 8%. In summary, the TCOD concentrations did not change substantially in the digesters during the tests and this was attributed to presence of acidogenic bacteria at a pH less than 6.

4.3.1.3 Hydrolysis

The effect of hydrolysis in the acid phase digesters was evaluated by examining the sCOD values. In System-1 with a 2 day HRT the sCOD of the control digester increased from 3800 to 10800 mg/L and for the pretreated digester it increased from 10760 to 22500 mg/L. Hence the sCOD increased 3 fold in the control digester whereas; it increased 2 fold in the pretreated digester. Reducing the HRT to 1 day in System-2 had no impact on the control digester's performance as the sCOD increased from 3250 to 9000 mg/L which was 3 times higher in the effluent than the feed value. However, the increment was less in the pretreated digester as the sCOD increased from 9600 to 12700 mg/L which was only 1.3 times higher in the effluent compared to the feed value. As a result, the sCOD increase was observed more in the control digester as compared to the pretreated digester for both HRTs.

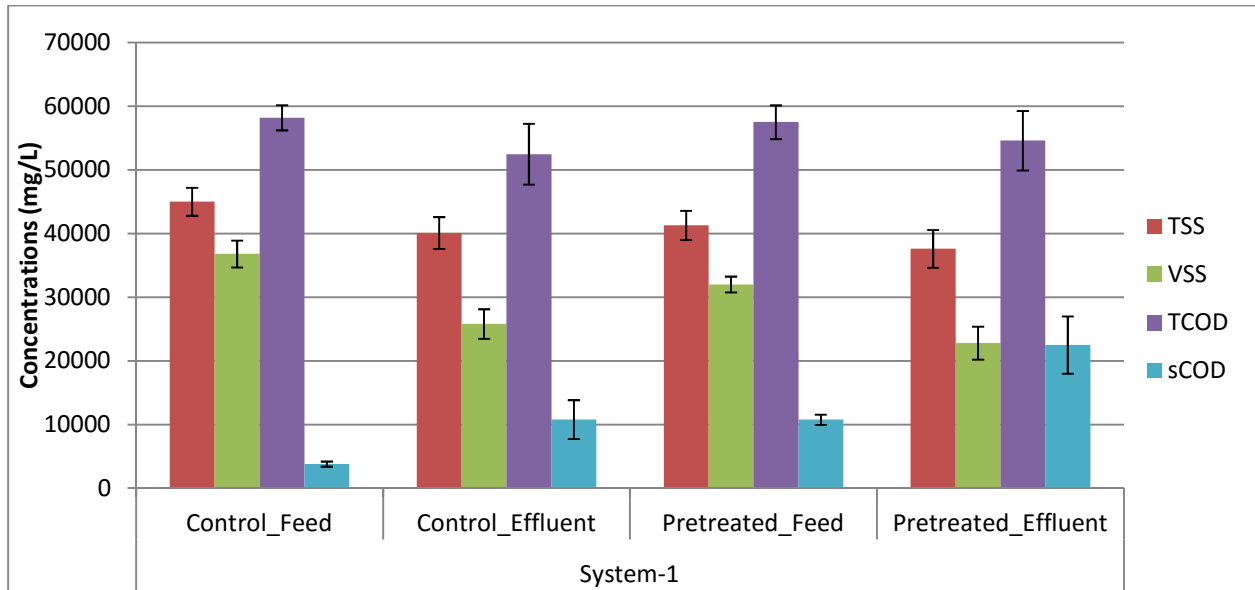

(a) Feed and effluent values of System-1.

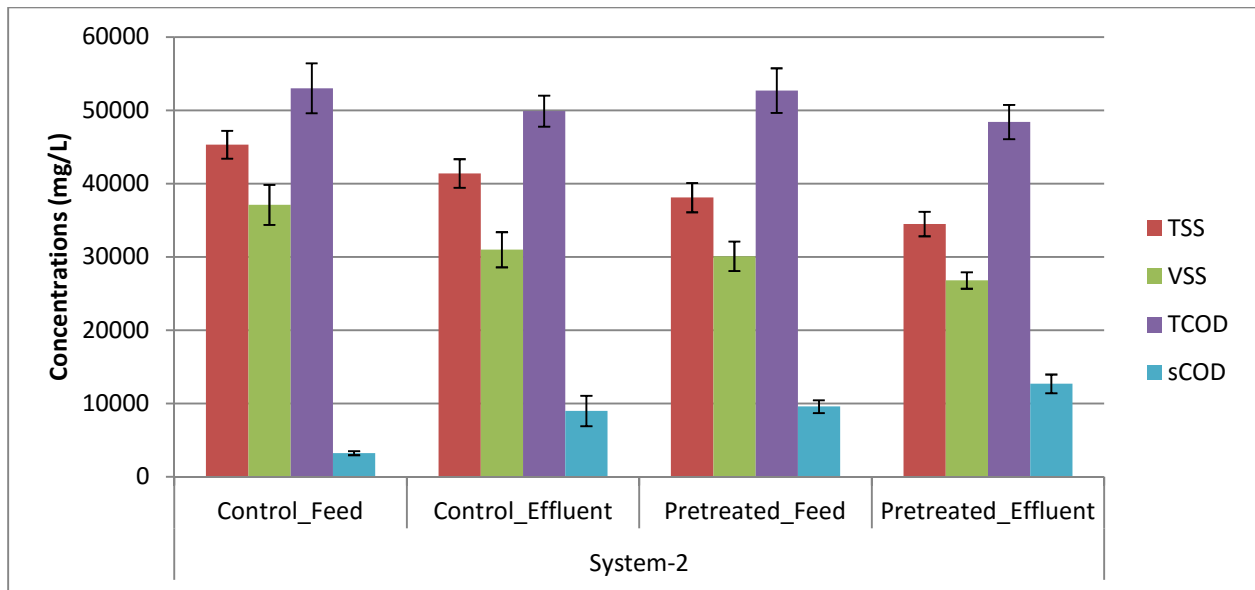

(b) Feed and effluent values of System-2.

Figure 4.7: Suspended solids and COD removal in the a) System-1 & b) System-2

The use of sCOD was not the only available indicator for hydrolysis in these tests because the control digester was fed with raw sludge whereas; the pretreated digester was fed with a more sterilized form of TWAS where a large amount of solubilisation had already taken place. Hence, COD solubilisation was

compared between System-1 and System-2 to evaluate the effect of HRT on the control and pretreated acid phase digester hydrolysis of particulate matter. Figure 4.8 presents the COD solubilisation of the control and pretreated digesters at the two HRTs. The COD solubilisation calculation was described in Section 2.1.2. The COD solubilisation values in the acidogenic phase digesters indicate the extent of hydrolysis in this step. In System-1, the COD solubilisation in the control digester was 11% as compared to 20% in the pretreated digester. By contrast, the reduced HRT in System-2 resulted in lower solubilisation in the pretreated digester (10%) as compared to the control digester (14%). However, in both Systems the particulates in the pretreated digester had undergone additional solubilisation that was achieved in the pretreatment stage (approx 25-34%). Considering this additional amount of solubilisation along with acid digester solubilisation it was concluded that pretreatment resulted in higher (43% in System-1 and 20% in System-2) solubilisation compared to the control system. The high amount of solubilisation with the pretreated feed was attributed to the HPTH of TWAS in the previous pre-treatment step. Furthermore, reducing HRT resulted in a decrease of solubilisation in the pretreated digester but increased the solubilisation in the control digester slightly (3% compared to System-1). To conclude, employing the HPTH pretreatment stage ahead of the acidogenic digester increased the overall solubilisation of the acidogenic digester but reduced HRT resulted in lower solubilisation in the pretreated digester.

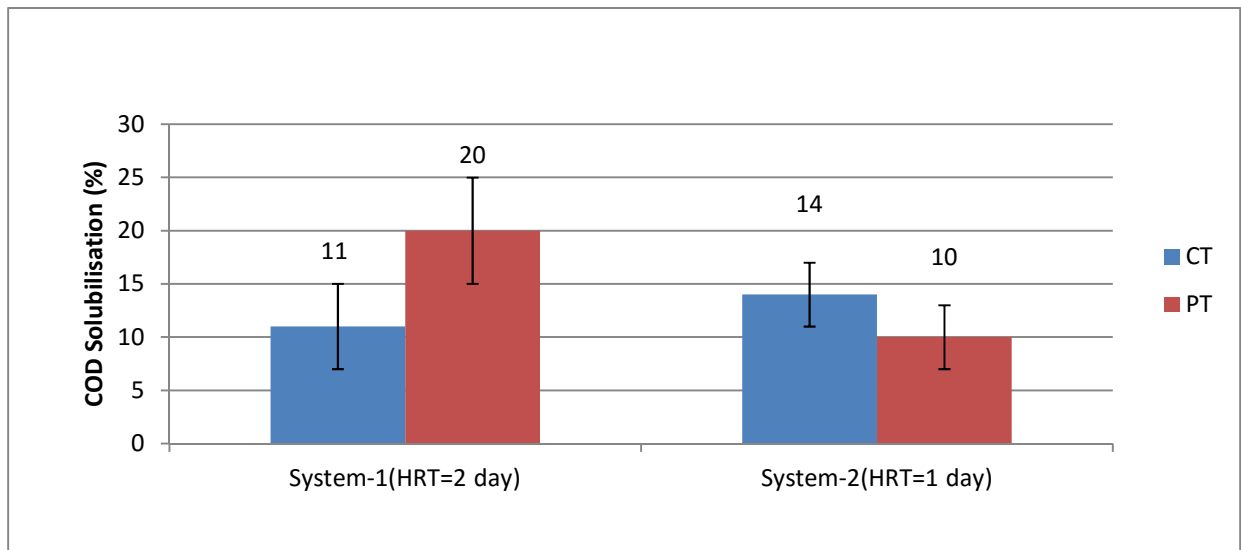

Figure 4.8: COD Solubilisation in Acid Phase digesters.

4.3.1.4 Suspended Solids

TSS removal is an indication of the removal of organic matter but may not be able to provide conclusive data in acidogenic phase. The gathered data may provide some information on the biodegradability of particulate matter in the systems for the acidogenic phase. The concentrations of TSS and VSS in the feed and effluent of the digesters are presented in Figure 4.7. The TSS concentrations decreased from 45000 mg/L to 40100 mg/L in the control digester for System-1, whereas for the pretreated digester they decreased from 41300 mg/L to 37600 mg/L. Hence, the control removed 11% of TSS as compared to 9% in the pretreated digester. In System-2, the TSS decreased from 45300 to 41400 mg/L in the control and from 38100 to 34500 mg/L in the pretreated digester, which resulted in a similar removal efficiency of 9% in both digesters. Despite of higher (30% in average of three systems) TSS removal efficiencies in the pretreated stage the TSS removal in the acidogenic digestion was almost same in both digesters. Therefore, the lack of improvement in TSS reduction in acidogenic phase between digesters indicates no significant improvement of particulate biodegradability occurred.

To confirm the result obtained from TSS and to investigate thoroughly, the VSS content of the digesters was also monitored. In System-1, the VSS decreased from 36800 mg/L to 25800 mg/L in the control whereas, it decreased from 32000 mg/L to 22800 mg/L in the pretreated digester. Hence, the VSS destruction was similar in both digesters with removal efficiencies of 30% and 29% in the control and pretreated digesters respectively. In System-2, the VSS decreased from 37100-31000 mg/L in the control and 30100-26800 mg/L in the pretreated digester with removal efficiencies of 16% in the control and 11% in the pretreated digester. The pretreatment stage reduced 34% VSS in the PTWAS compared to the raw TWAS sample. Compared to that the nominal differences (1% in System-1 and 5% in System-2) observed between the control and pretreated digesters it can be concluded that pretreatment did not increase the biodegradability of the particulate matter in the acidogenic phase digester.

4.3.1.5 VFA Production

Intermediate products such as sugars, long chain fatty acids and amino acids are generated by hydrolysis. Fermentative microorganisms present in the acidogenic phase consume these as substrate to produce readily biodegradable VFAs during acidification. The concentration and composition of various acids in the VFAs are presented in Figure 4.9 to characterize the extent of fermentation in the digesters in this study. From Figure 4.9 it can be observed that the VFA in the acidogenic phase increased dramatically for both control and pretreatment digesters and in both Systems. In System-1, the increment of TVFA in the

effluent compared to the feed value was greater in the control digester than the pretreated digester. In the control digester the VFA increased 15 times from 575 ± 27 mg COD/L to 8696 ± 317 mg COD/L whereas, in the pretreated digester the increment was 13 times increased from 705 ± 45 mg COD/L to 9140 ± 335 mg COD/L. The TVFA of control digester in System-2 increased from 600 ± 50 mg COD/L to 5040 ± 965 mg COD/L, which was an 8 fold increase compared to the feed value. The TVFA of the pretreated digester in System-2 increased from 695 ± 55 mg COD/L to 6850 ± 390 mg COD/L, which was an increase of 10 fold compared to the feed value. Thus, decreasing HRT decreased the amount of TVFA produced in System-2 but increased the rate of production by 2 fold in the pretreated digester compared to the control digester.

The effluent concentrations of the control and pretreated digesters were of interest because these VFAs will contribute to the methane generation in the later stage. The actual concentrations of TVFA in System-1 with 2 day HRT in the control and the pretreated digesters were to 8700 ± 315 mg COD/L and 9140 ± 335 mg COD/L respectively. The effluents in the digesters had a nominal difference of 5% only. In System-2 with 1 day HRT the actual concentrations of TVFA in the control and the pretreated digesters were to 5040 ± 965 mg COD/L and 6850 ± 390 mg COD/L respectively. Hence, the effluent was 36% higher in the pretreated digesters compared to the control digesters. Therefore, lowering the HRT to 1 day increased the VFA production in the pretreated digester and produced more readily biodegradable products.

The performance of downstream methanogenic stage is dependent on both the concentration and proportion of individual VFAs produced in the acidogenic phase. In System-1, the dominant VFA in the effluent for both control and pretreated digesters was propionic acid followed by acetic, butyric, iso-butyric, valeric and iso-valeric acid. However, in System-2, different patterns were observed in the control and pretreated effluent. Acetic acid was dominant in pretreated effluent whereas, propionic was dominant in the control effluent. The presence of high content of acetic acid and butyric acid in both System-1 & 2 effluents ensures high methane production in the methanogenic phase. Acetic acid and butyric acids have been reported to be the preferred precursors of methane generation (Hwang et al., 2001, Merlin et al., 2014).

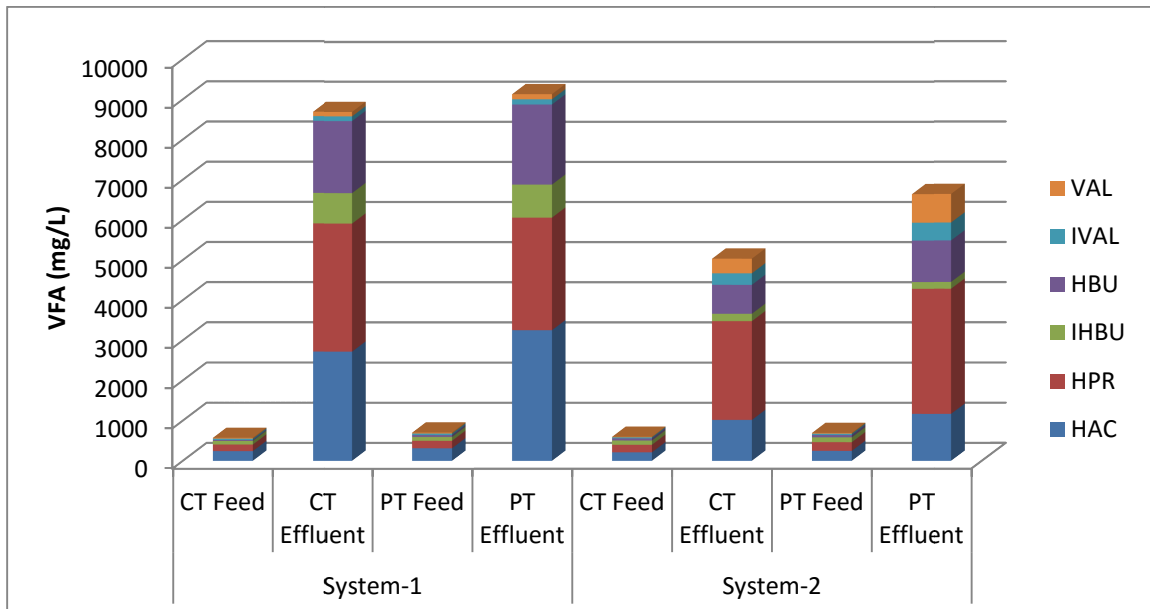

Figure 4.9: VFA accumulation in Acid phase for System-1 & 2.

4.3.1.6 Ammonia and TKN

Ammonia was expected to increase through the acid phase digester as hydrolysis of proteins was observed within the digester and this releases ammonia from amino acids. The ammonia increase was noticeable in both systems and in the control and pretreated digesters. Table-4.5 represents the Ammonia, TKN, alkalinity and pH of the feed and the effluent from the acidogenic phase digesters. In System-1, the ammonia increased from 120 to 800 mg N/L in the control digester and 140 to 1080 mg N/L in the pretreated digester. Hence, ammonia increased 7 fold in the control and 8 fold in the pretreated digester. Similar results were observed in System-2, as the ammonia increased from 125 to 720 mg N/L in the control digester and from 150 to 940 mg N/L in the pretreated digester. System-1 increased the ammonia in the acidogenic phase as compared to System-2 because of the higher HRT. In both systems almost similar amount of ammonia increase was observed which implies the fermentation rate for ammonia producing compounds was the same. However, as previously discussed solubilisation was higher in the pretreated digesters and hence it would appear that the fermentation of carbohydrate and lipids may have occurred at different rates than proteins.

It was expected that the TKN should be constant throughout the processes as TKN represents the total amount of ammonia and organic nitrogen present inside the digester. The organic nitrogen decreases to release ammonia in the digester and as a result the TKN value should remain same throughout the

process. In the acidogenic phase a decline in TKN amount was observed after digestion for both systems. However, the decline was less than 5 % in all of them, which was deemed to be negligible in both systems.

Table 4-5: Other parameters of Acid phase digesters

Parameter	Unit	System-1				System-2			
		CT Feed	CT Effluent	PT Feed	PT Effluent	CT Feed	CT Effluent	PT Feed	PT Effluent
NH ₃	mg N/L	120 ±16	800 ±120	140 ±20	1080 ±190	125 ±15	720 ±40	150 ±6	940 ±45
TKN	mg N/L	3030 ±110	2850 ±90	3080 ±110	2940 ±100	3090 ±40	2900 ±70	3150 ±30	3090 ±80
Alkalinity	mg as CaCO ₃ /L	1350 ±100	2291 ±200	1480 ±90	2770 ±120	1200 ±120	3440 ±210	1450 ±150	3220 ±150
pH	N/A	5.95 ±.15	5.53 ±.20	5.75 ±.20	5.56 ±.15	5.7 ±.15	5.4 ±.10	5.55 ±.35	5.6 ±.10
TVF A/Alkalinity	N/A	0.44	2.20	0.46	2.40	0.46	2.50	0.47	2.80

4.3.2 Dynamic Tests

In two stage digestion the acidogenic phase is separated from the methanogenic phase to accelerate the hydrolysis rate and hence reduce the overall HRT of the systems. In addition, it was expected that more readily biodegradable compounds would be produced by fermentation to produce more methane in the later phase. It was anticipated that HPTH of the TWAS would further intensify the solubilisation of PCOD into simple sCOD by improving the hydrolysis and fermentation rates in the acidogenic phase. As observed in section 3.2.1, HPTH increased the solubilisation of TWAS to 25-34%, and it was expected that the increased sCOD should generate more VFAs (readily biodegradable compounds) in the pretreated digester as opposed to the control digester. A set of batch tests were conducted on the acidogenic phase to identify if the solubilised PTWAS enhanced the hydrolysis rate to produce more VFAs.

The dynamic testing was conducted in three phases. Phases 1 & 2 were conducted using the existing acidogenic digesters (Control and Pretreated); whereas Phase 3 was conducted in a more controlled environment with 1 L serum bottles (Control and Pretreated), where 67% inoculums and 33% substrate

was added. In all three phases, the acidogenic digester effluents were used as inocula. TWAS was employed as a substrate for the Control configuration and PTWAS was employed for the pretreated configuration. The results presented for each phase corresponded to one reaction cycle, which was 36 hours for Phase 1 and 48 hours for Phases 2 & 3. All the data presented in the following section represent duplicate analytical results. The variability between duplicate tests was found to be less than 3%, and therefore the individual results were not shown in the graphs.

4.3.2.1 Phase-1

Phase-1 was operated with 50% inocula and 50% feed and samples were collected from the digesters every 2 hours for the first 12 hours and every 4 hours for the period from 24 to 36 hours. Samples were not collected in the time between 12 and 24 hours. The concentrations of the parameters were plotted against time to observe the cumulative effects of hydrolysis and fermentation. This test was designed to observe any improvement of hydrolysis and generation of fermentable products as a result of acidogenic activity of the microorganisms. As a result, it was deemed important to maintain the conditions suitable for acidogenic activity that should have a pH less than 6 whereas methanogenic activity generally occurs at pH values between 6.6 to 7.8 (Maspolim et al., 2015). The pH of the effluents from the digesters was therefore monitored to confirm that the conditions were appropriate for maximum acidogenic activity. Figure 4.10 summarizes the pH of the control and pretreated digesters throughout the test period. The pH of both digesters remained relatively constant throughout the period with average values of 5.47 ± 0.13 and 5.46 ± 0.07 in the control and pretreated digesters respectively, which had a variation of less than 3%. Thus, the pH of both digesters remained below 6, implying suitable operation condition for acidogenic activity. The pH was similar in the pretreated digester despite the HPTH pretreatment. This may have been due to the ammonia increase in pretreatment step that accumulated in the acidogenic digester.

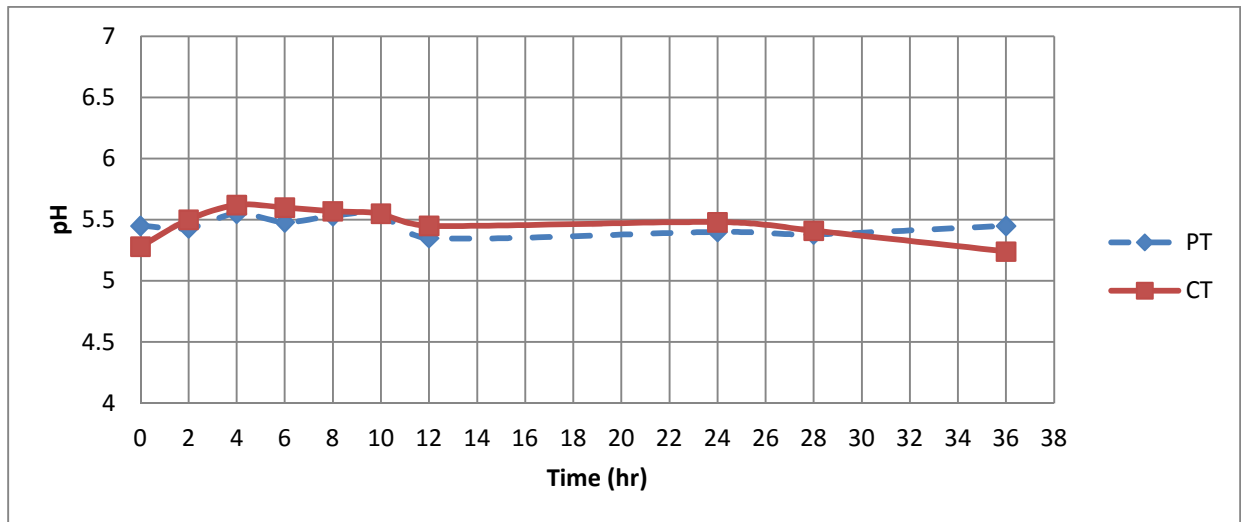

Figure 4.10: pH in digesters for Phase-1 Dynamic test.

VSS was employed as an indicator of the physical properties of the solids in the effluents; hence the removal of the VSS was employed to indicate solubilisation in the digesters. The effluent VSS values observed in each digester were compared to determine if PT resulted in higher VSS removal due to hydrolysis. Figure 4.11 presents the VSS removal in the digesters for the duration of the batch tests. A noticeable hydrolysis rate was observed in the period from 0 to 12 hours. Rates of hydrolysis were derived from the gradients of best fit line during the 0 to 12 hour section of the graphs and the R^2 values indicated that the data displayed a good fit. Table 4.6 shows the rates that were estimated. From Table 4.6 it can be seen that the rate of destruction of VSS in the control and pretreated digesters was different, and a higher rate of 562 mg/L-hr was observed in the control, whereas the pretreated test showed a VSS destruction rate of 498 mg/L-hr. It was hypothesized that the lower rate observed in the pretreated digester was because pretreatment sterilized the TWAS and as a result the rate at which the microorganisms degraded the substrates was slower compared to that of the raw TWAS.

The total VSS for the control digester decreased from 34200 mg/L to 26100 mg/L whereas, the VSS in the pretreated digester decreased from 28600 mg/L to 21160 mg/L. Hence, the control and the pretreated digesters achieved removal efficiencies of 23% and 26% respectively inside the digesters. From this batch test the pretreated digester average removal efficiency increased by 3% which was statistically insignificant. Thus, the VSS destruction was the same in both tests. However, as discussed in Section 3.2, 33% (in System-1) VSS destruction occurred during the pretreatment stage, and this contributed to the overall VSS destruction in the pretreated digester for the acidogenic phase. As a result the overall VSS

destruction including pre-treatment and digestion was 59%. Despite negligible differences (only 3%) between the control and pretreated digesters in the VSS destruction values, when PT and acid phase digestion were considered collectively, the overall VSS destruction improved. The combined effect suggested that PT improved overall VSS degradation.

Table 4-6: Initial conversion rates in Phase-1 dynamic test

Parameter	Unit	Time (hr)	Control		Pretreated	
			Rate	R ²	Rate	R ²
VSS	mg/L-hr	0-12	624	0.97	498	0.96
sCOD	mg/L-hr	0-12	650	0.95	217	0.92
NH ₃ -N	mg/L-hr	0-12	23	0.96	26	0.91

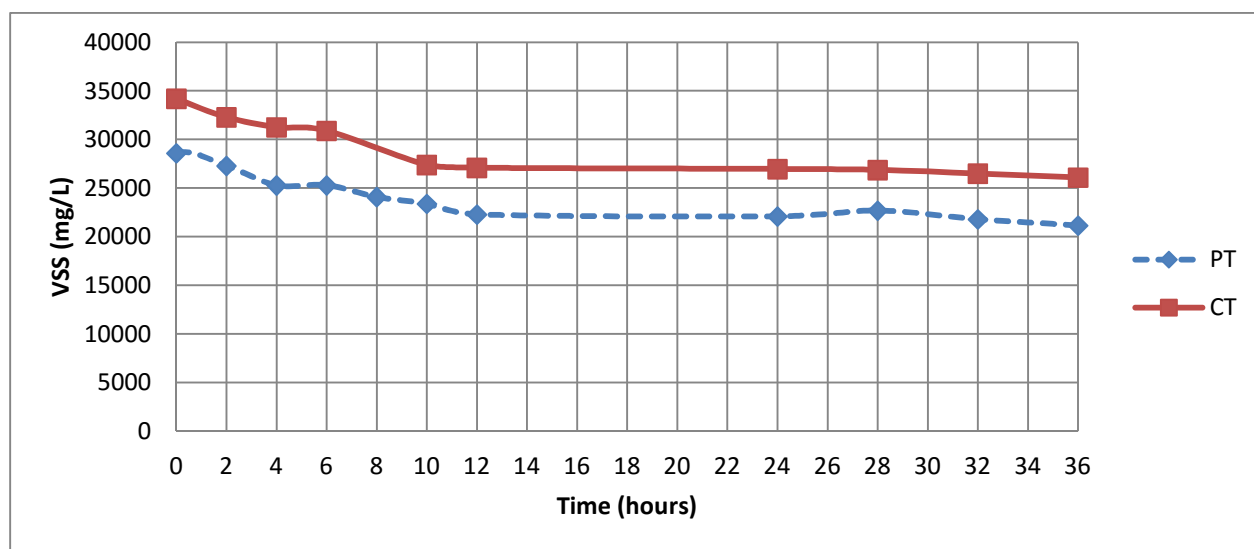

Figure 4.11: VSS concentrations in Phase-1 dynamic test.

The sCOD concentrations were employed as an additional indicator of the extent of solubilisation in the digesters. Figure 4.12 shows the sCOD concentrations in the control and pretreated digesters. The sCOD responses were generally consistent with the previously described VSS results. The sCOD concentrations in the pretreated effluent increased from 12200-15700 mg/L as compared to the control effluent that increased from 4800-11500 mg/L. The initial 2.5 fold higher sCOD concentrations of PTWAS were due to the HPTH pretreatment that was accomplished before the acidogenic phase. The overall increase of the sCOD in the batch tests was 129% in the control digester compared to 28% in the pretreated digester.

However, combining the pretreatment effect in the previous stage pretreated digester generated 36% more effluent sCOD in the pretreated digester compared to the control digester and the initial sCOD concentration was 154% compared to the initial control digesters concentration. Thus, the pretreated values increased at a slower rate but as a result of pretreatment in the earlier stage the increment of sCOD started from a higher value which ultimately achieved higher soluble products.

The rates of increase in the control and pretreated digesters were compared to confirm these observations. Figure 4.12 reveals a noticeable increase in sCOD in the period between 0 and 12 hours in both digesters. Beyond 12 hours the sCOD was further solubilised in the pretreated digester, whereas in the control the sCOD remained almost constant. Solubilisation rates were derived from the gradients of the best fit line during the 0 to 12 hours section of the graphs and the R^2 values indicated that the data displayed a good fit. Table-4.6 shows the observed rates in the period between 0-12 hours. The slope of sCOD in the control had a value of 572 mg/L-hr, whereas the pretreated effluent slope had a value of 170 mg/L-hr. Hence, the sCOD results showed the rate of solubilisation in the control digester was higher (more than threefold) than the pretreated digester. Thus, the control digester was able to solubilise a substantial fraction of the particulate organics; whereas in the PTWAS digester much of the particulate organics was already solubilised as a result of pretreatment. Thus the pretreated digester had lower availability of particulates that were available for conversion to sCOD.

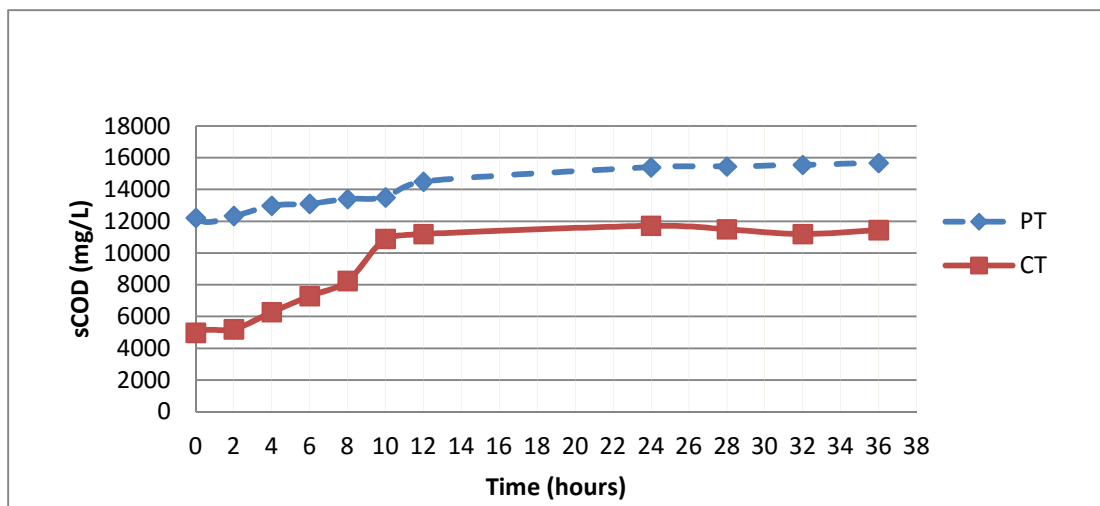

Figure 4.12: sCOD in digesters for Phase-1 dynamic test.

To better characterize the hydrolysis rates in the batch tests the PCOD present in the digesters was fit with a single first order model (Equation 3.3) and a dual kinetic model (Equation 3.8). The IWA anaerobic digestion model ADM1, utilizes first-order kinetics to describe hydrolysis of particulate matter (Batstone et al., 2002). However the sludges tested in this work were expected to include slowly biodegradable biomass and more readily biodegradable particulate matter. These components have been reported to hydrolyze with different rates under anaerobic conditions (Yasui et al., 2008). Hence, in order to describe the readily biodegradable and slowly biodegradable fractions of the particulate solids of TWAS and PTWAS, the more complex dual hydrolysis model was employed (Straub et al., 2006 & Ramirez et al., 2009). On the basis of this background, both hydrolysis models (Equations 3.3 and 3.8) were employed to examine which model best described the hydrolysis process in the acid phase digestion systems.

Table 4-7: Single and dual model hydrolysis values with RMSE for Phase-1 dynamic test

Digesters	Dual					Single	
	Readily hydrolysable rate coefficient, K_r (d^{-1})	Readily Biodegradable COD fraction, P_r	Slowly hydrolysable rate coefficient, K_s (d^{-1})	Slowly Biodegradable COD fraction, P_s	RMSE	Average hydrolysis, K_{hyd} (d^{-1})	RMSE
Control	2.67	0.22	0.02	0.78	0.0005	0.23	0.02
Pretreated	2.54	0.1	0.04	0.9	0.003	0.28	0.02

The PCOD data was derived as the difference between corresponding TCOD and sCOD values. The data and models were plotted as a fraction of concentrations against time in Figure 4.13. By visual observation it was concluded that in both digesters, the dual model showed a better fit than the single first order kinetics for PCOD solubilisation. Further, the root mean square error (RMSE) was employed as the minimizing function for the model curve fitting and as a result the lower value of RMSE represents better fit. Table 4.7 represents the hydrolysis rate constants and RMSE values for both models and digesters. The readily and slowly hydrolysis constants obtained from the dual model were 2.67 and 0.02 per day for the control digester; whereas 2.54 and 0.04 per day for the pretreated digester. From Table 4.7 it was found that the RMSE values for both digesters were much smaller in the dual model compared to the single. As a result the hydrolysis rate constants obtained from the dual model were deemed to be more appropriate for this study.

The readily biodegradable hydrolysis coefficients (K_r) for the control and pretreated digesters were within the range of values reported by Yausi et al., 2006. However, the readily hydrolyzable coefficients (K_r) for the digesters were higher than those reported in the literature. The higher K_r values may have been due to the presence of active heterotrophic biomass in the TWAS (Parker et al., 2008) that might contribute to the hydrolysis process and increase the coefficient value. The values for the slowly biodegradable hydrolysis coefficients (K_s) for both digesters were low compared to most of the literature. However, they were within the range reported by Gujer and Zehnder (1983) who analyzed the hydrolysis rates of various substrates. The lower K_s values were indicative of the relatively slow decay of microbial cells in the TWAS and PTWAS (i.e., protein, carbohydrate, lipid, and inert fractions). From the higher values of the slowly hydrolyzable rates of the pretreated digester could be that the control has a higher (.22) fraction of readily biodegradable PCOD. Thus, it can be concluded that hydrolysis process was faster for the acidogenic phase to solubilise particulate compounds and create readily biodegradable products in the control digester than the pretreated digester. However, the readily hydrolysis rates were similar, with a less than 5% difference. To clarify which digester shows the higher hydrolysis rate, Phase-2 was conducted with smaller substrate to inocula ratio to observe the trends more accurately.

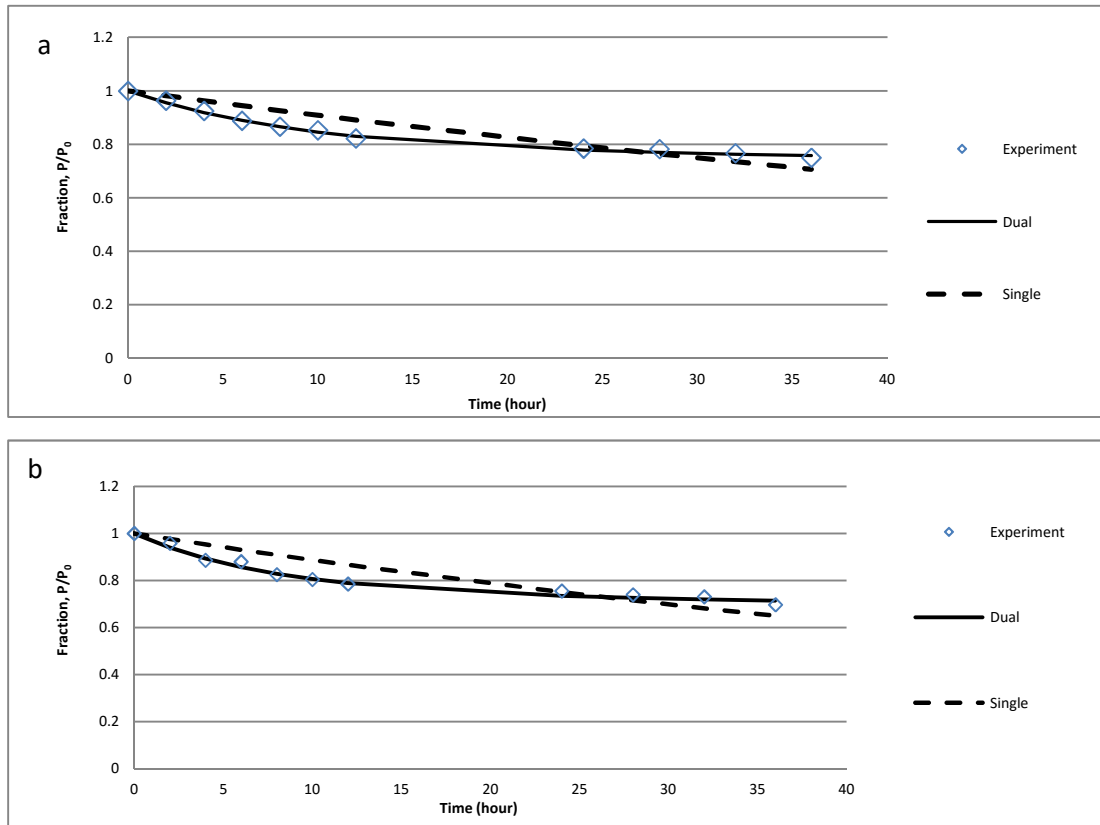

Figure 4.13: Hydrolysis rate constant determination for phase-1 dynamic test a) control, b) pretreated.

The hydrolysis of protein and subsequent fermentation of amino acids was expected to cause the ammonia to increase in the digester. Figure 4.14 shows the increase of ammonia in the digesters. The highest rate of increase in ammonia was observed between 0 and 12 hours for both digesters, and hence the rate of increase was similar to the sCOD response. The ammonia concentrations increased from 420 to 710 mg N/L and from 655 to 1075 mg N/L in the control and pretreated digesters respectively. The overall increase for 36 hours compared to raw TWAS was 4.45 fold for the control digester compared to 5.51 for the pretreated digester. From Table-5, the rates of NH_4 release in the period between 0 and 12 hours obtained from the gradients of the best fit line within that period shows that the rates in the pretreated was 26 mg/L-hr and the control digester was 23 mg/L-hr. Thus, pretreatment also increased the rate of fermentation of proteins in the first 12 hours. The observed rates of sCOD production (Table-5) were different than the release of ammonia. Thus, either the sCOD generation did not break down proteins to the extent that ammonia was released or the proteins were hydrolyzed and fermentation of amino acid

occurred at a different rate than the remaining organic matter (i.e., carbohydrate, lipids, inert fractions, etc.).

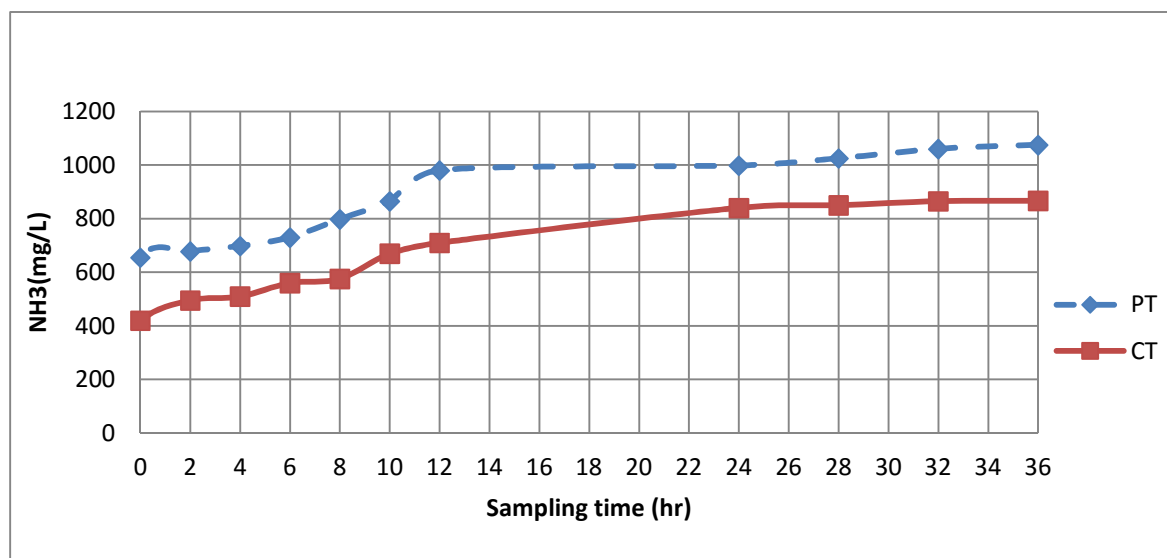

Figure 4.14: Ammonia concentrations in control and pretreated digesters for Phase-1 dynamic test.

The compounds solubilised in the pretreatment stage and the acidogenic phases were expected to be converted into readily biodegradable VFAs by acidogenic microorganisms. The formation of acetic and butyric acids in the acidogenic phase is important for methane generation in the later stage (Merlin et al., 2014). Hence, the concentrations and proportion of individual VFAs produced in the acidogenic stage were examined. The presence of high concentrations of VFAs formed in the acidogenic phase was likely responsible for the decreased pH levels as shown in Figure 4.10. Figures 4.15 and 4.16 shows the VFA results obtained from the dynamic test for the control and pretreated digesters respectively. The TVFAs consisted of six acids namely acetate, propionate, butyrate, iso-butyrate, iso-valerate, and valerate. As shown in Figure 4.15 and 4.16, the TVFA concentrations decreased for the first 2 hours and this was attributed to the activity of methanogens in the inocula of the digesters that degraded the available VFA. As a result, the increase in TVFA was calculated from 2 hours in both digesters. In the control, TVFAs increased from 7400 mg COD/L to 9970 mg COD/L in the first 28 hours, whereas the TVFA in the pretreated digester increased from 12800 mg COD/L to 14800 mg COD/L within the first 12 hours. When, compared to the TVFA of the raw TWAS (5017 mg/L), the TVFA of the control digester increased by 1.98 fold and the pretreated digester increased by 2.96 fold. Thus, pretreatment generated more TVFA in the pretreated digester compared to the control digester.

It was deemed important to focus on the TVFA distribution as the different VFAs have different biodegradability. For example, the normal forms of fatty acids have been reported to degrade faster as compared to their iso forms in anaerobic digesters (Bolzonella et al., 2007). Propionic acid had the highest concentrations in the control followed by acetic acid and valeric acid. In the pretreated digester the dominant acid was also propionic acid, but was followed by butyric and acetic acid. The elevated presence of acetic acid and butyric acids in the pretreated digester suggests that the VFAs of this digester would be more readily available to the methanogens when compared to the control digester's acid components.

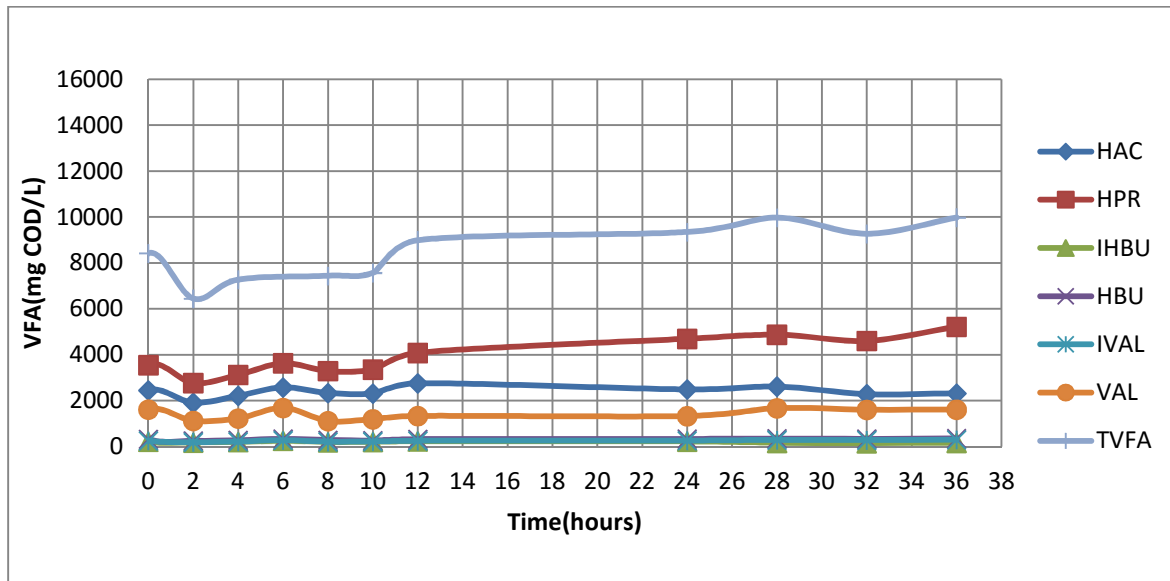

Figure 4.15: VFAs in the control digester for Phase-1 dynamic test.

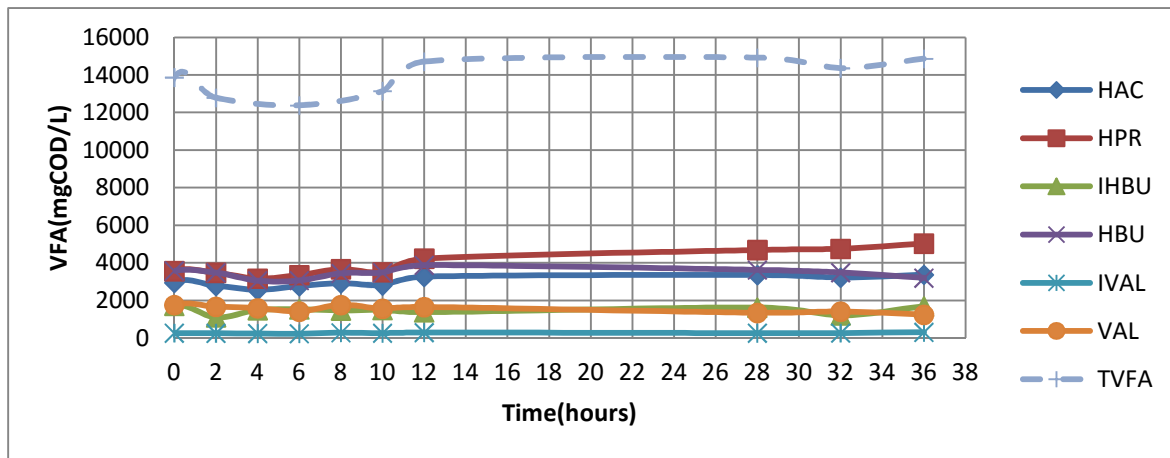

Figure 4.16: VFAs in the pretreated digester for Phase-1 dynamic test.

It was anticipated that TCOD concentrations would not change in the digesters during the test because of the reduced activity of the methanogenic bacteria at a pH less than 6. Figure 4.17 presents TCOD concentrations in the control and pretreated digesters. From Figure 4.17 it can be seen that the TCOD in the control digester decreased from 53840 mg/L to 48120 mg/L, which represented a removal efficiency of 11 % and in the pretreated digester the TCOD decreased from 52980 mg/L to 44070 mg/L with a removal efficiency of 16%. The relatively modest removal efficiencies may have been due to challenges associated with collecting representative samples from the reactors because in the acidogenic phase TCOD reduction was not expected

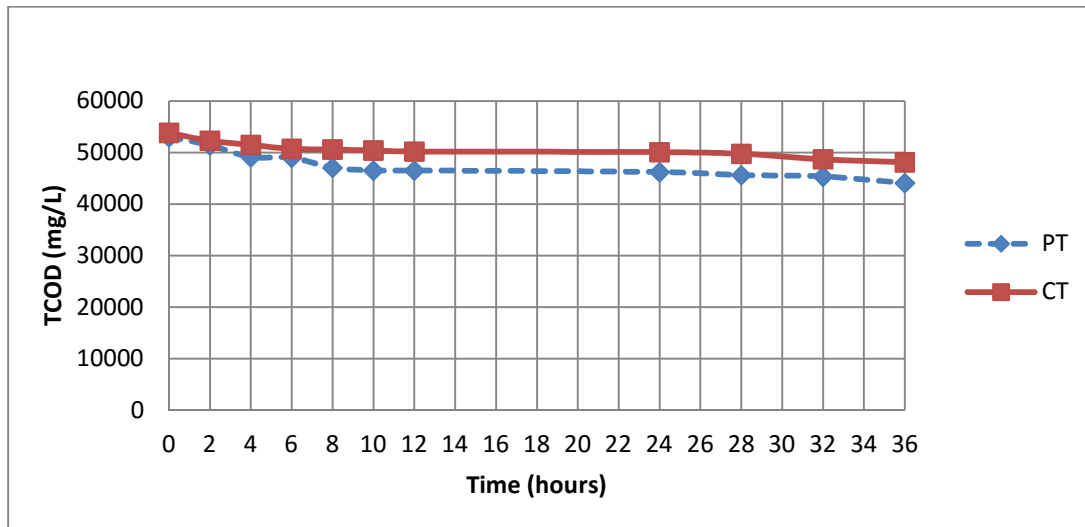

Figure 4.17: TCOD concentrations in digesters for Phase-1 dynamic test.

In summary, the Phase-1 dynamic tests on TWAS and PTWAS revealed that that pretreated digester was capable of producing more readily biodegradable compounds compared to the control digester as observed in the TVFA production. The amount of VSS destruction and sCOD solubilisation was higher in the pretreated digesters, which implies that pretreatment of the TWAS, made it possible to achieve more solubilisation in the acidogenic phase. The hydrolysis rate constant of particulate matter in the pretreated digester was almost the same for the readily biodegradable portion in both digesters. However, the slowly biodegradable rate constant was twofold more in the pretreated digester than the control, which implies the solubilisation of particulates was easily converted to VFAs. The component of the VFA was mostly readily biodegradable compounds in the pretreated digester compared to the control. The Phase-1 dynamic test showed that higher VFAs can be readily produced by fermentation of PTWAS in the previous stage; however, only 26–33% of the influent TCOD of PTWAS was converted to VFA and for

the TWAS it was even lower (15-20%). In order to verify if decreasing the substrate will change the hydrolysis and fermentation rates, Phase-2 was implemented with a lower substrate to inoculums ratio.

4.3.2.2 Phase-2

Phase-2 was operated with 1 L substrate and 2 L of inocula. In Phase-1 it was observed that the pH of the digesters increased after 4 days when they were fed with only TWAS or PTWAS. It was believed that the absence of PS in the feed was responsible for this response. As a result, Phase 2 was conducted with similar configuration as Phase 1, but with a lower substrate fraction to better observe the hydrolysis and fermentation rates. In addition, the pH of the feed was adjusted in Phase 2 to minimize methanogenic activity within the digesters. The initial pH was controlled by adding 95% hydrochloric acid to both control (0.05 ml HCl/ cm³ of feed TWAS) and pretreated (0.03ml HCl/ cm³ of feed TWAS) digesters to keep the pH at 5.0. The duration of Phase 2 was 48 hours, because Phase 1 suggested additional activity would occur beyond 36 hours.

As mentioned in the previous section, the pH of the effluents from the digesters was monitored to confirm the acidogenic activity inside the digesters. Figure 4.18 summarizes the pH of the control and pretreated digesters throughout the test period. The pH of both digesters remained relatively constant for 0 to 12 hours and a slight increase was observed in pH beyond that time. The pH value varied from 5.06 to 5.22 and 4.89 to 5.4 in the control and pretreated digesters respectively, which had a variation of less than 10%. The pH of both digesters remained below 6, implying suitable operation condition for acidogenic activity.

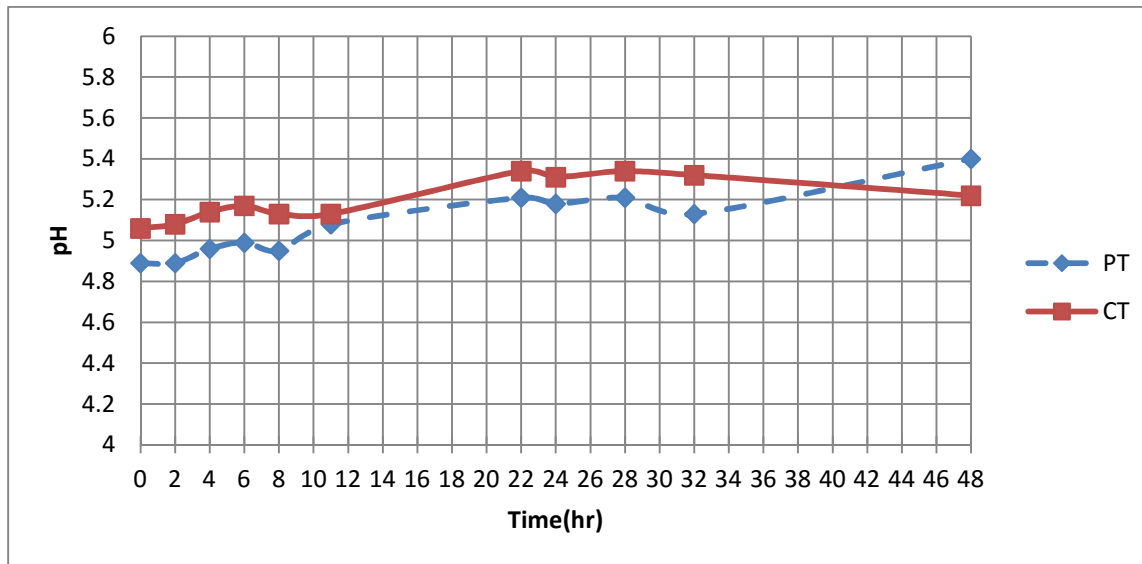

Figure 4.18: pH in digesters for Phase-2 Dynamic test.

The removal of VSS was employed to indicate solubilisation in the digesters with low substrate to inocula ratio. The effluent VSS values observed in each digester were compared to determine if PT resulted in higher VSS removal due to hydrolysis. Figure 4.19 shows the VSS concentrations in the control and pretreated digester. The VSS for the control digester decreased from 36300 mg/L to 26700 mg/L whereas, the VSS in the pretreated digester decreased from 27500 mg/L to 20800 mg/L. Hence, the control and the pretreated digesters achieved removal efficiencies of 26% and 24% respectively. The 2% increase in the control digester was statistically insignificant and hence similar VSS destruction occurred in both digesters. However, VSS destruction occurred during the pretreatment stage, and this contributed to the overall VSS destruction in the pretreated digester for the acidogenic phase. As a result the overall VSS destruction with pre-treatment was 57%. Despite negligible differences (only 2%) between the control and pretreated digesters VSS destruction values, when PT and acidogenic phase digestion were considered collectively, the overall VSS destruction improved. The combined effect suggested that PT improved overall VSS degradation. When compared with Phase-1 a similar trend was observed in the control and pretreated digester with negligible (only 3%) difference of VSS destruction in the digestion systems.

Table 4-8: Initial conversion rates in Phase-2 dynamic test

Parameter	Unit	Time(hr)	Control		Pretreated	
			Rate	R2	Rate	R2
VSS	mg/L-hr	0-12	500	0.91	380	0.97
sCOD	mg/L-hr	0-12	561	0.96	150	0.57
NH ₃ -N	mg/L-hr	0-12	33	0.93	24	0.98

VSS destruction rates were calculated as described in phase 1 (Table 4.8) and it was found that the rate of VSS destruction in the control digester was 120 mg/L-hr higher than that of the pretreated digester. Compared to Phase-1, the rate of the control digester was similar with only a 5% difference, whereas the rate of the pretreated digester was much lower (70% compared to Phase-1 pretreated digester) in Phase-2 as a result of low substrate availability.

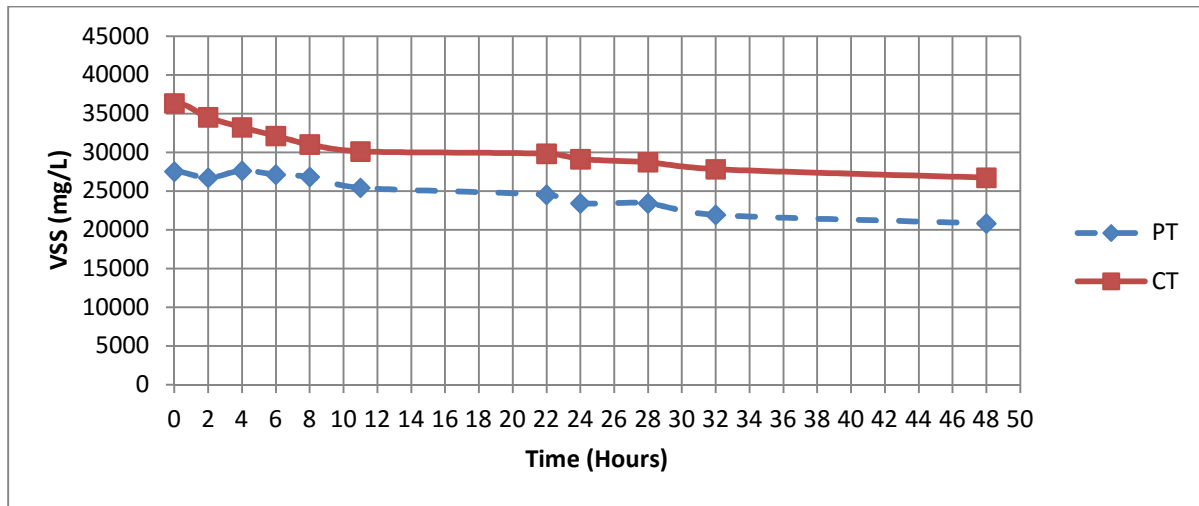

Figure 4.19: VSS concentrations in digesters for Phase-2 dynamic test.

The sCOD concentrations in the control and pretreated digesters were employed as an additional indicator of hydrolysis. Figure 4.20 presents the sCOD concentrations in the control and pretreated digester. The sCOD results for the control digester were consistent with the VSS results in terms of increasing concentrations in the periods from 0 to 12 hours, and 22 to 48 hours while the pretreated digester showed no noticeable increase in sCOD concentrations after 22 hours. The overall sCOD increase with the raw TWAS sCOD was 3.75 fold in the control digester and 4.75 fold in the pretreated digester. At the beginning of the test the pretreated digester contained 1400 mg/L more soluble COD as a result of

hydrolysis in the pretreatment stage that increased the solubilisation in the pretreated digester during the test. The final sCOD concentration, as a result of hydrolysis in the control digester was 13500 mg/L. A similar amount of sCOD was obtained in the pretreated digester before 12 hours, suggesting that pretreated digester was capable of reducing HRT. To conclude, there was a greater increase in sCOD for the control than the pretreated WAS during the test period suggesting that some of the materials solubilised by previous pretreatment stage could also be solubilised by bacteria.

A noticeable increase in sCOD was observed in the period between 0 and 12 hours in both digesters. Beyond 12 hours the sCOD was further solubilised in the control digester, whereas in the pretreated digester the sCOD remained almost constant. Solubilisation rates were derived from the gradients of the best fitted line from the 0 to 12 hours section of the graphs and the R^2 values indicated that the data displayed a good fit. Table-5 shows the observed rates in the period between 0-12 hours. The slope of sCOD in the control had a value of 561 mg/L-hr, whereas the pretreated effluent slope had a value of 150 mg/L-hr. Hence, the sCOD results showed the rate of solubilisation in the control digester was higher (more than threefold) than the pretreated digester. Thus, the control digester was able to solubilise a substantial fraction of the particulate organics; whereas in the PTWAS digester much of the particulate organics were already solubilised as a result of pretreatment. Thus the pretreated digester had lower availability of particulates that were available for conversion to sCOD. The rates observed in Table 4.8 show the control sCOD rates were only 12% lower than Phase-1; whereas it was more than 2 fold for the pretreated digester in Phase-2 compared to Phase-1. This implies the inocula responded favorably when the substrate loading was low. The microorganism ratio was higher than the substrate and as a result the rate of solubilisation was higher in both digesters compared to Phase-1.

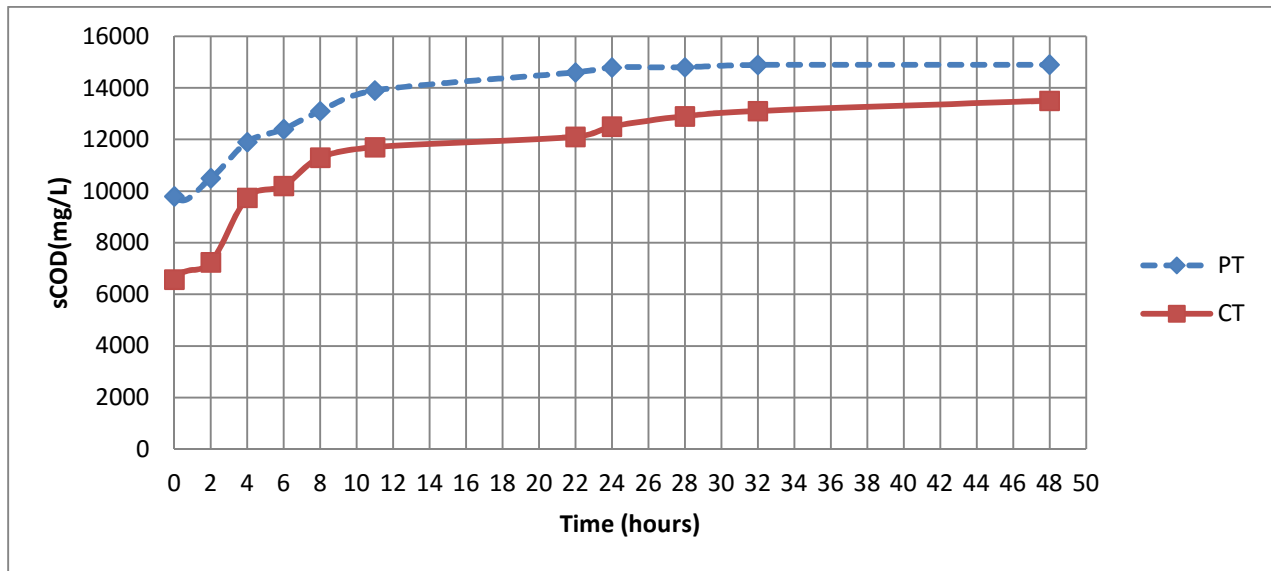

Figure 4.20: sCOD Concentrations in digesters for Phase-2 dynamic test.

Table 4-9: Single and dual model hydrolysis values with RMSE for Phase-2 dynamic test

Digesters	Dual					Single	
	Readily hydrolysable rate coefficient, K_r (d^{-1})	Readily Biodegradable COD fraction, P_r	Slowly hydrolysable rate coefficient K_s (d^{-1})	Slowly Biodegradable COD fraction, P_s	RMSE	Average hydrolysis, K_{hyd} (d^{-1})	RMSE
Control	3.42	0.20	0.03	0.8	0.0008	0.17	0.05
Pretreated	2.82	0.09	0.03	0.91	0.0006	0.18	0.02

As described in Phase-1 both hydrolysis models (Equations 3.5 and 3.8) were employed to examine which model best described the hydrolysis process in the acid phase digestion systems. From Table-4.9 it was clearly noticed that the RMSE values for both digesters were much smaller in the dual model compared to the single model. As a result the hydrolysis rate constants obtained from the dual model were deemed to be acceptable for this Phase as well. The readily hydrolysable rate coefficient (K_r) for the pretreated digester was within the range of values reported in Yausi et al., 2006. However, the readily hydrolysis coefficients (K_r) for the control digester was higher than those reported in the literature. The slowly hydrolysable constants were lower compared to literature values.

Figure 4.21 presents the reduction of PCOD concentrations in the digesters. As previously described the hydrolysis rate constants (k values), PCOD fractions and RMSE values were obtained from the non-linear regression function for single and dual model fitted to the graphs by MS excel. The readily hydrolysis constants obtained from the dual model were slightly higher in pretreated digester compared to the control with a value of 2.8 per day as compared to 3.4 per day in the control digester. This value was obtained for 0 to 12 hours. The slowly hydrolysis constants showed same value of .03 per day for a 22 to 48 hours for both digesters which implies the slow process is still occurring in the earlier time period but the contribution was negligible compared to first 0 to 12 hours. The readily biodegradable fraction of the control digester (.22) was almost 50% higher than the pretreated fraction (.09). Thus, depending upon the fractions of readily and slowly biodegradable PCOD and the rate constants it could be concluded that the overall rates of solubilisation were higher for the control than the pretreated digester.

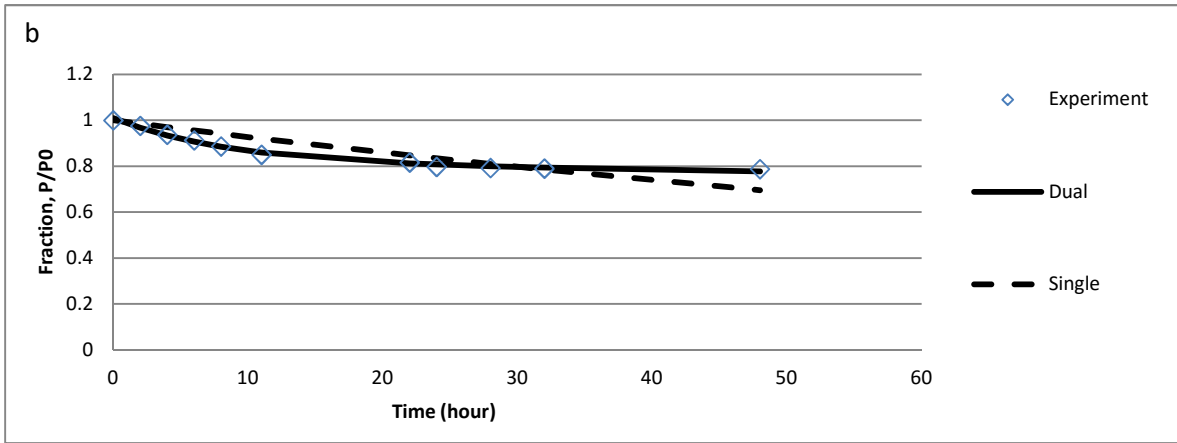
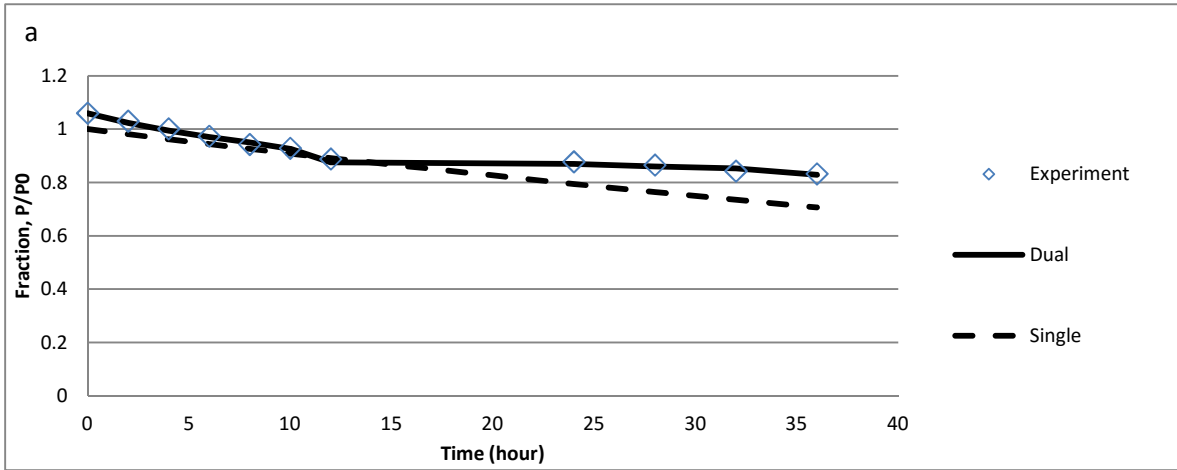

Figure 4.21: Hydrolysis rate constant determination for Phase-2 dynamic test a) control, b) pretreated.

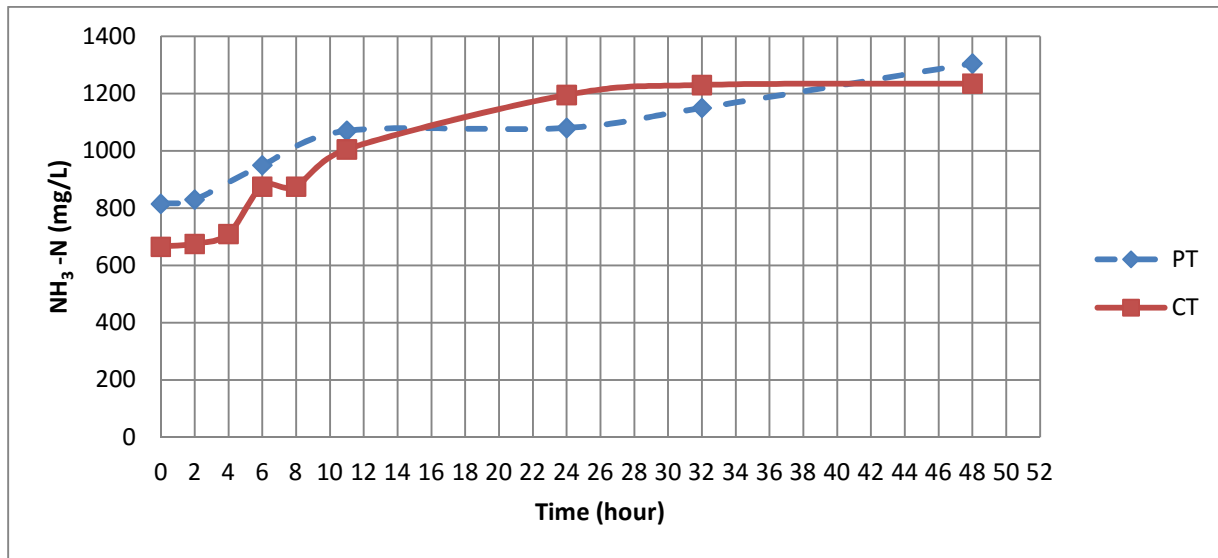

Figure 4.22: Ammonia concentrations in digesters for Phase-2 dynamic test.

Ammonia increase was employed as an indicator of hydrolysis of proteins inside the digesters. Figure 4.22 shows the increase of ammonia in the effluents of the digesters. The highest rate of increase in ammonia was observed between 0 to 12 hours for both digesters that was similar to Phase-1. From Table-6, rates of 33 mg/L-h and 24 mg/L-hr were obtained for the control and the pretreated digesters respectively for this period. The ammonia concentrations increased from 665 to 1235 mg N/L and from 815 to 1305 mg N/L in the control and pretreated digesters respectively. The overall increase for 36 hours compared to raw TWAS was 7.9 fold for the control digester compared to 8.4 fold for the pretreated digester. The increments were closer and were also observed in the graph. The increased ammonia observed in the beginning of the test at 0 hour as a result of pretreatment in the previous stage eventually became closer to control digesters value and the final ammonia values were almost same in both digesters. The observed rates of sCOD production (Table-5) were different than the release of ammonia. Thus, similar to Phase-1 either the sCOD generation did not break down proteins to the extent that ammonia was released or the proteins were hydrolyzed and fermentation of amino acid occurred at a different rate than the remaining organic matter (i.e., carbohydrate, lipids, inert fractions, etc.). The hydrolysis of protein and subsequent fermentation of amino acids occurred in a higher rate compared to Phase-1 in both digesters and the trends were similar.

The production of VFAs was employed as an indication of fermentation inside the digesters and hence the productivity of the acidogenic phase. Figures 4.23 and 4.24 presents the TVFA concentrations and VFA

compositions in the digesters. The TVFA concentrations decreased for the first 2 hours and this was attributed to the activity of methanogens in the inocula of the digesters that degraded the available VFA. As a result, the increase in TVFA was calculated from 2 hours in the pretreated digester only. In the control TVFAs increased from 7766 mg COD/L to 10845 mg COD/L from 0 to 48 hours whereas; the TVFA in the pretreated digester increased from 10782 mg COD/L to 14617 mg COD/L. Compared to the TVFA of the raw TWAS (7884 mg/L), the TVFA of the control digester increased by 1.37 fold and the pretreated digester increased by 1.85 fold. Thus, pretreatment generated more TVFA in the pretreated digester compared to the control digester.

As mentioned earlier it was important to observe the composition of the VFAs generated. In this Phase, Propionic acid had the highest concentrations in the control followed by acetic acid and butyric acid. In the pretreated digester the dominant acid was acetic acid followed by propionic and butyric acid. The elevated presence of acetic acid and butyric acids in the pretreated digester suggests that the VFAs of this digester would be more readily available to the methanogens compared to the control digester's acid components. As previously mentioned, butyric acid and acetic acid are the precursors for methane generation. This pattern could impact the pretreated digester in later methanogenic process as acetic acid was the simplest form of VFA to convert into methane.

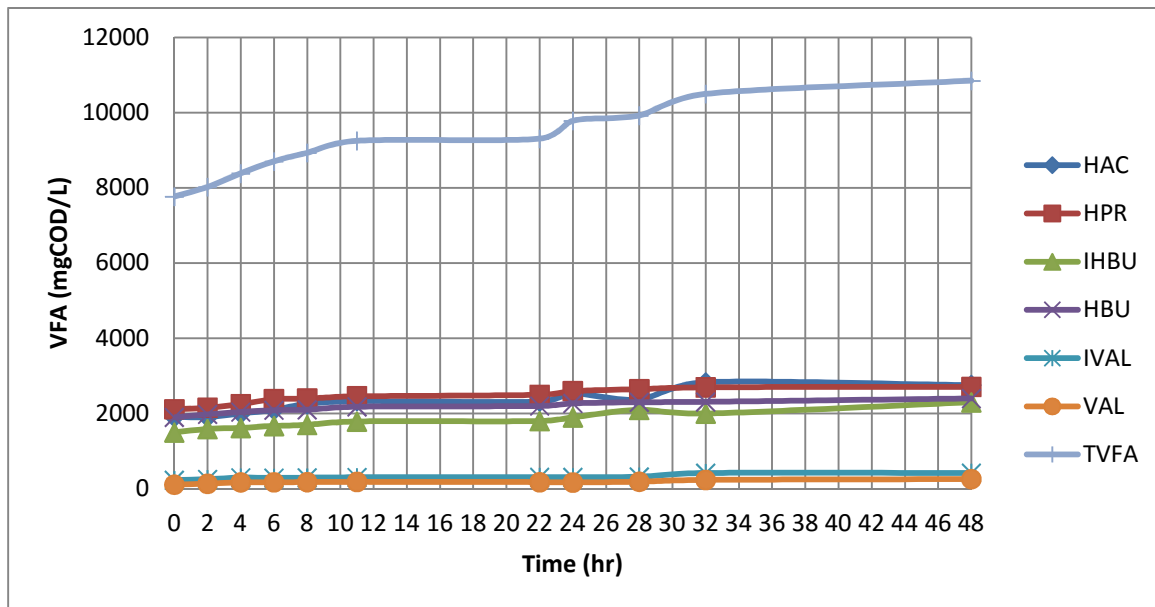

Figure 4.23: Increase of VFAs in the control digester for Phase-2 dynamic test.

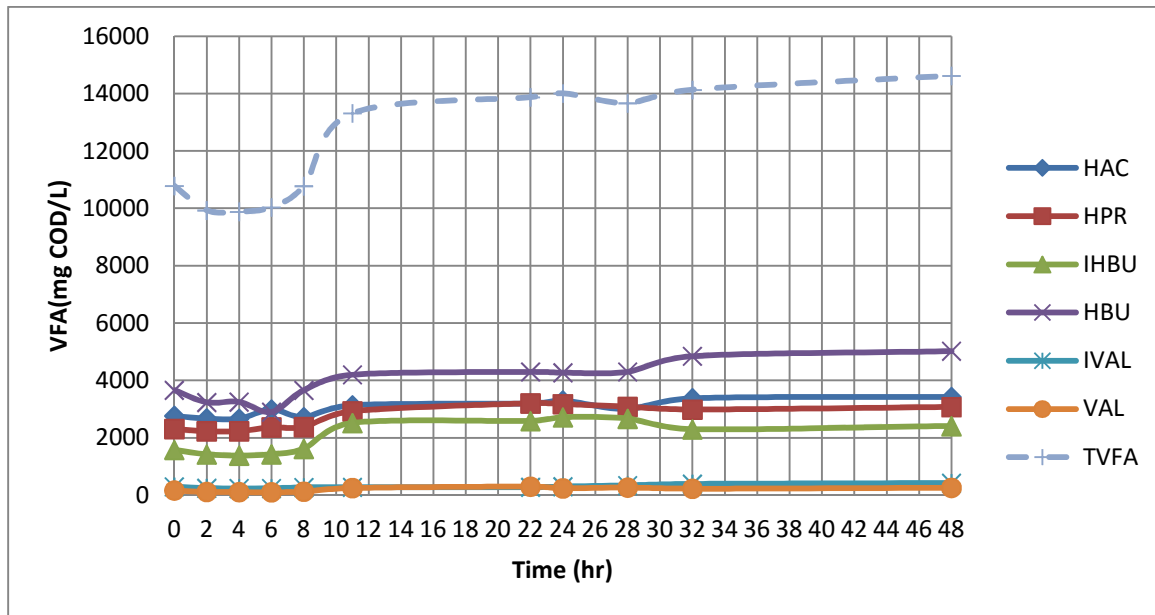

Figure 4.24: Increase of VFAs in the pretreated digester for Phase-2 dynamic test.

TCOD removal in the digester was deemed to be indicative of substrate utilization by the methanogenic community. Figure 4.25 shows the TCOD concentration change in the 48 hour period. There was no change in the TCOD until 12 hour in both digesters. After 12 hour, both TCOD values started decreasing at a very low rate with only 14% decrease in the control and only 10% decrease in the pretreated digester. As a result of the pH being less than 6, it was assumed that TCOD concentrations would not change in the digesters during the test. The TCOD in the control digester decreased from 58400 mg/L to 54200 mg/L and from 51200 mg/L to 47500 mg/L in the pretreated digester. The TCOD removal in this phase followed similar pattern of the TCOD removal (4 % for the control and 9% for the pretreated) observed in Phase-1. This variation in the Phases indicates experimental error and was negligible.

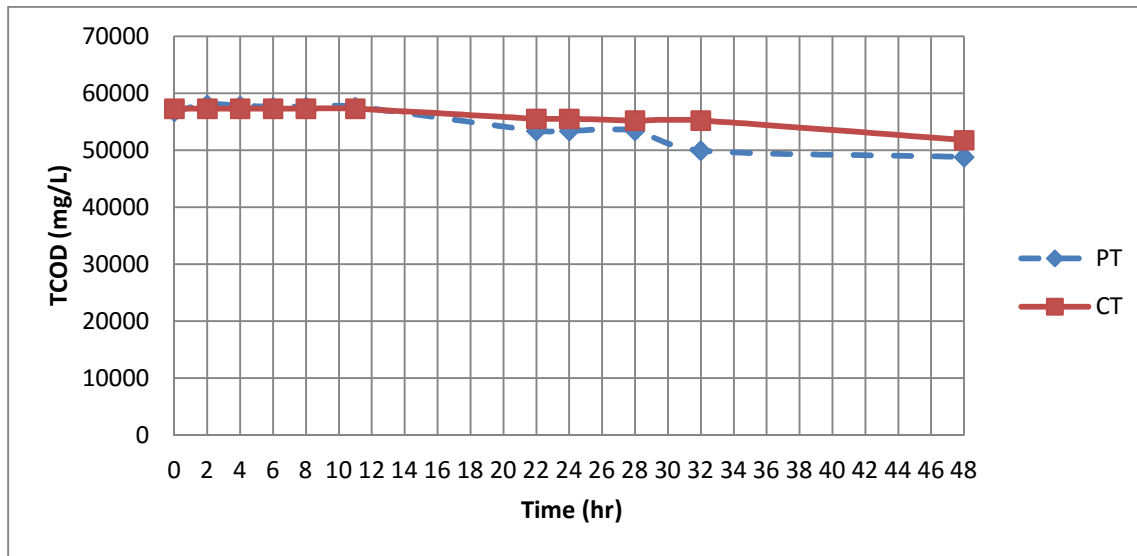

Figure 4.25: TCOD concentrations in the digesters for Phase-2 dynamic test.

To conclude, similar patterns of hydrolysis and fermentation were observed in Phase-2 and Phase-1. The amount of VSS destruction and sCOD solubilisation was higher in the pretreated digesters, which implies that pretreatment of the TWAS, made it possible to achieve more solubilisation in the acidogenic phase. The lower readily biodegradable fraction of the PTWAS might be due to pretreatment of TWAS that already produced readily biodegradable compounds that were converted to VFAs in the digesters. Thus, the composition of the VFA showed more readily biodegradable compounds in the pretreated digester as compared to the control. The Phase-2 dynamic test showed that higher VFAs can be readily produced by fermentation of PTWAS in the previous stage and that increment followed in the acidification digester and finally produced more TVFAS than the control digester. Thus, pretreatment ahead of the acidogenic stage was capable of producing more readily biodegradable compounds in form of TVFAs.

4.3.2.3 Phase-3

Phase-3 was conducted in a more controlled environment to verify the hydrolysis and fermentation trends observed in Phase-1 & 2. Phase-3 was operated with 33% substrate and 67% inocula. The inocula were collected from the control and pretreated acid phase digesters and each 1L serum bottle was filled with 670 ml of inocula. The remaining 330 ml of the bottle was filled with either raw TWAS or PTWAS. Details of the set up can be found in the methodology section 2.3. The results presented in all the following graphs represent the average result of the samples collected from three bottles. Each point in the graph represents the average value and the error bars represent the standard deviations.

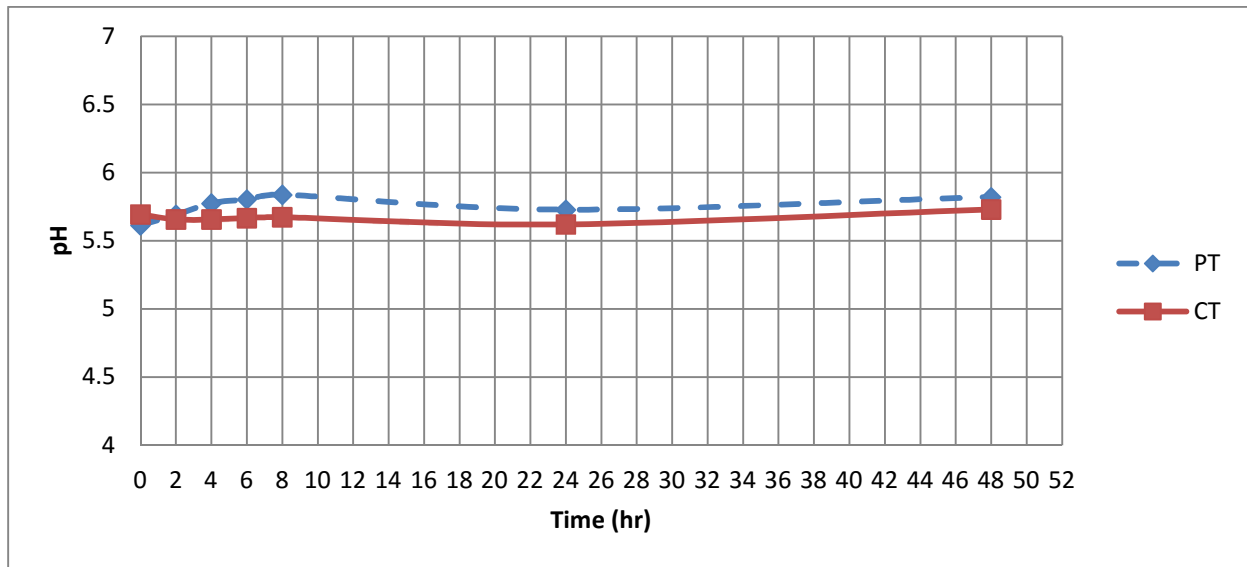

Figure 4.26: pH in digesters for Phase-3 Dynamic test.

The pH of the effluents from the digesters was monitored to confirm the acidogenic activity. Figure 4.26 summarizes the pH of the control and pretreated digesters throughout the test period. The pH of both digesters remained relatively constant throughout the period with average values of 5.75 ± 0.08 and 5.67 ± 0.03 in the control and pretreated digesters respectively, and the variation was less than 2%. The pH of both digesters remained below 6, implying suitable operation condition for acidogenic activity.

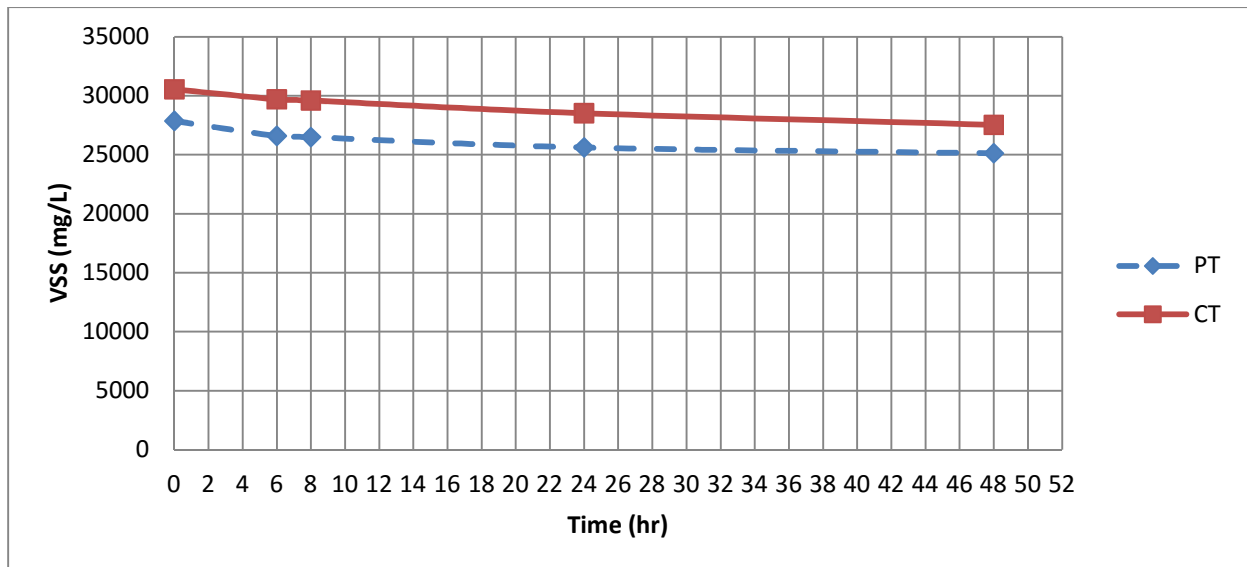

Figure 4.27: VSS concentrations for Phase-3 dynamic test.

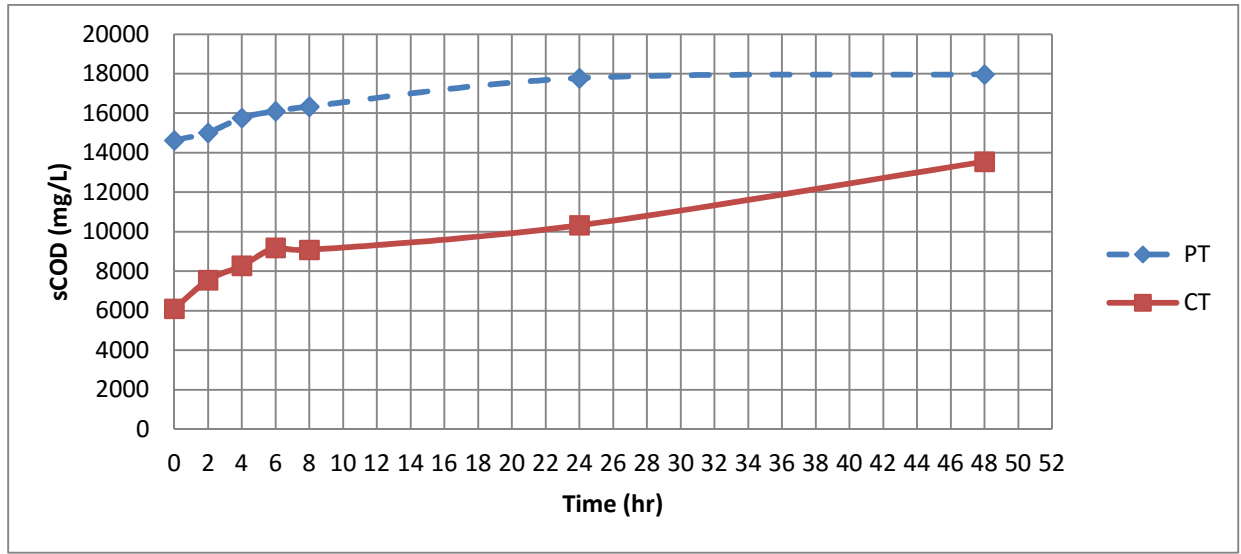

Figure 4.28: sCOD concentrations for Phase-3 dynamic test .

Table 4-10: Rate of parameters in Phase-2 dynamic test

Parameter	Unit	Time(hr)	Control		Pretreated	
			Rate	R2	Rate	R2
VSS	mg/L-hr	0-8	337	0.96	261	0.92
sCOD	mg/L-hr	0-8	380	0.89	225	0.96
NH ₃ -N	mg/L-hr	0-8	37	0.95	41	0.99

The VSS and sCOD were characterized to assess the impact of PT on solubilisation in the acid phase digestions. Figures 4.27 and 4.28 shows the VSS and sCOD concentrations in the control and pretreated bottles. The VSS concentrations in the pretreated tests were lower ranging from 27860 to 25120 mg/L as compared to 30550 to 27530 mg/L in the control bottles. The overall removal of VSS from raw TWAS was also calculated and the average VSS removal in the pretreated digester was 23% while the control digester removal efficiency was 15%. Thus, when the pretreatment stage was considered higher solubilisation occurred in the pretreated digester. The results for this response were similar to those found in the previous two Phases.

The sCOD concentrations increased steadily in both tests with higher (14620- 17960 mg/L) concentrations in the pretreated tests as compared to the control (6100-13550 mg/L). While the pretreated sCOD concentrations were higher as observed in the previous sections the overall increase of sCOD in the

control was 38% as compared to 84% in the pretreated. The rate of increase in sCOD was higher in the first 8 hours (Table 4.10) in both digesters. From the results it was clear for both the control and pretreated sludges that the sCOD increased proportionately with the destruction of VSS. Hydrolysis was more rapid in the control as compared to the pretreated. However, the increased sCOD obtained in the pretreatment stage resulted in the pretreated digester a higher overall concentration (14600 mg/L) of sCOD than was created in the control digester (13500 mg/L).

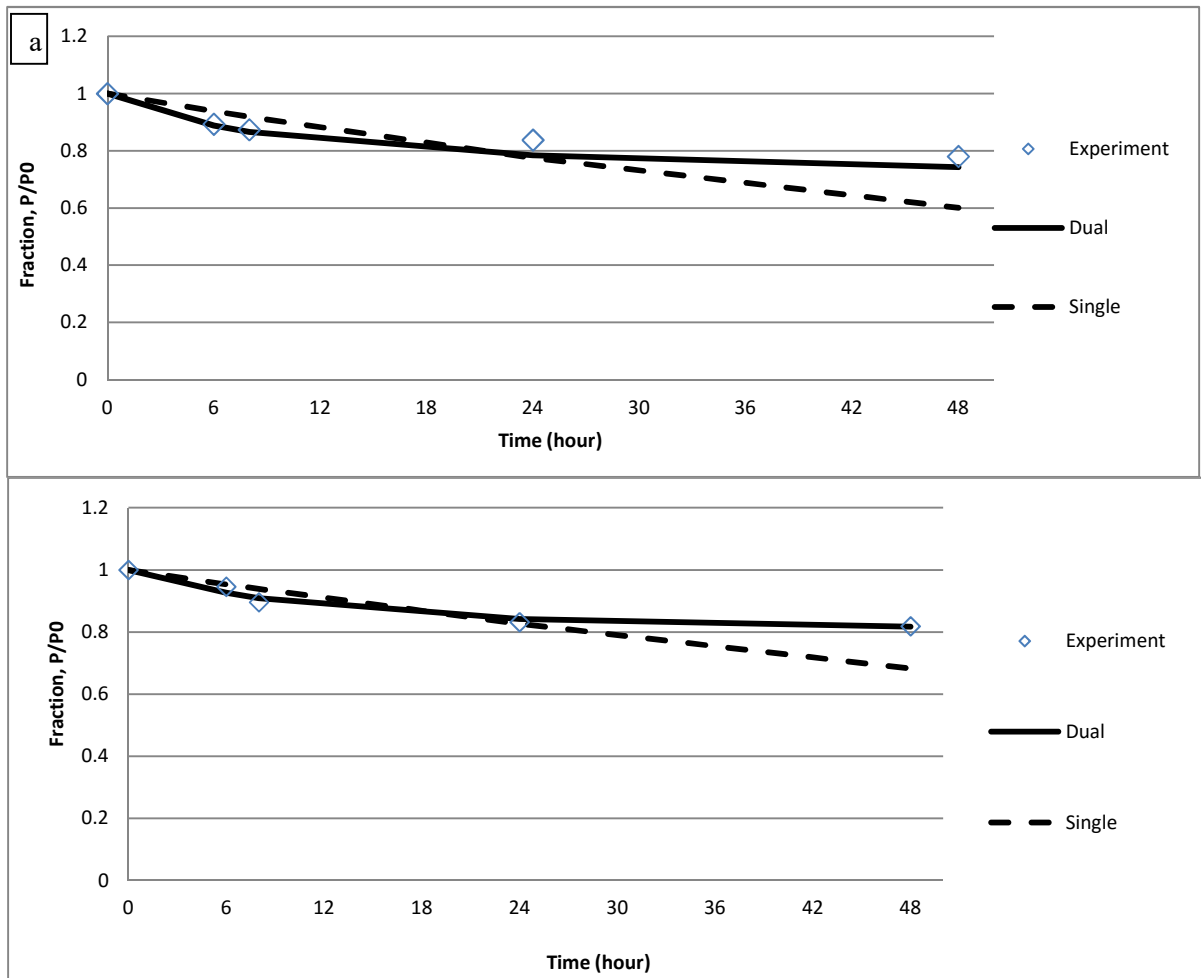

Figure 4.29: Hydrolysis rate constant determination for Phase-3 dynamic test a) control & b) pretreated.

Figure 4.29 represents the reduction of PCOD concentrations in the control and pretreated digesters. The hydrolysis rate constants (k values) and RMSE values were obtained with the same procedure mentioned

in section 3.3.1.1 in Phase-1. Table 4.11 presents the hydrolysis parameters and RMSE values for both models and digesters. From Table 4.11 it can be seen that the RMSE values for both digesters were smaller in the dual model as compared to the single model as found in the other two Phases. As a result the hydrolysis rate constants obtained from the dual model were deemed to be acceptable for this Phase as well.

The readily hydrolysable COD constant obtained for the dual model was higher in the control digester as compared to the pretreated with a value of 3.19 per day in the control and 2.24 per day in the pretreated digester. The slowly hydrolysable constants were also higher in the control digester with a value of .05 per day compared to 0.01 per day in the pretreated digester for 22 to 48 hours. The readily biodegradable fraction (.17) of the control digester was 50% higher compared to the readily biodegradable fraction (.08) of the pretreated digester. Thus, it was concluded that hydrolysis process was faster in the control digester for the acidogenic phase and this was attributed to the presence of more readily biodegradable particulates in the control sludge as the particulates in the pretreated sludge had already been substantially solubilised in pretreatment.

Table 4-11: Single and dual model hydrolysis values with RMSE for Phase-3 dynamic test

Digesters	Dual					Single	
	Readily hydrolysable rate coefficient, K_r (d^{-1})	Readily Biodegradable COD fraction, P_r	Slowly hydrolysable rate coefficient, K_s (d^{-1})	Slowly Biodegradable COD fraction, P_s	RMSE	Average hydrolysis, K_{hyd} (d^{-1})	RMSE
Control	3.19	0.17	0.05	0.83	0.004	0.15	0.04
Pretreated	2.24	0.08	0.01	0.92	0.0006	0.12	0.02

Figure 4.30 shows the ammonia concentrations as an alternative indicator of hydrolysis and fermentation in the tests. Ammonia concentrations increased in both the control (690-1190 mg/L) and pretreated (750-1370 mg/L) systems, and hence the pretreated values were higher as compared to the control. The overall increase of ammonia in the pretreated digester was 5.49 fold and in the control was 4.78 fold when compared to the raw ammonia in TWAS. The results confirm that the PTWAS was hydrolysed in the

pretreatment stage to produce organic nitrogen that was readily degraded to release ammonia in the acidogenic phase digester. As observed from the graph the ammonia started from the same amount in both reactors with only 8% difference between them and started diverging at 8 hours and finally at 48 hours the pretreated digester contained 15% more ammonia as compared to the control digester. The results indicate that the fermentation of amino acids was higher in the pretreated digester as compared to the control.

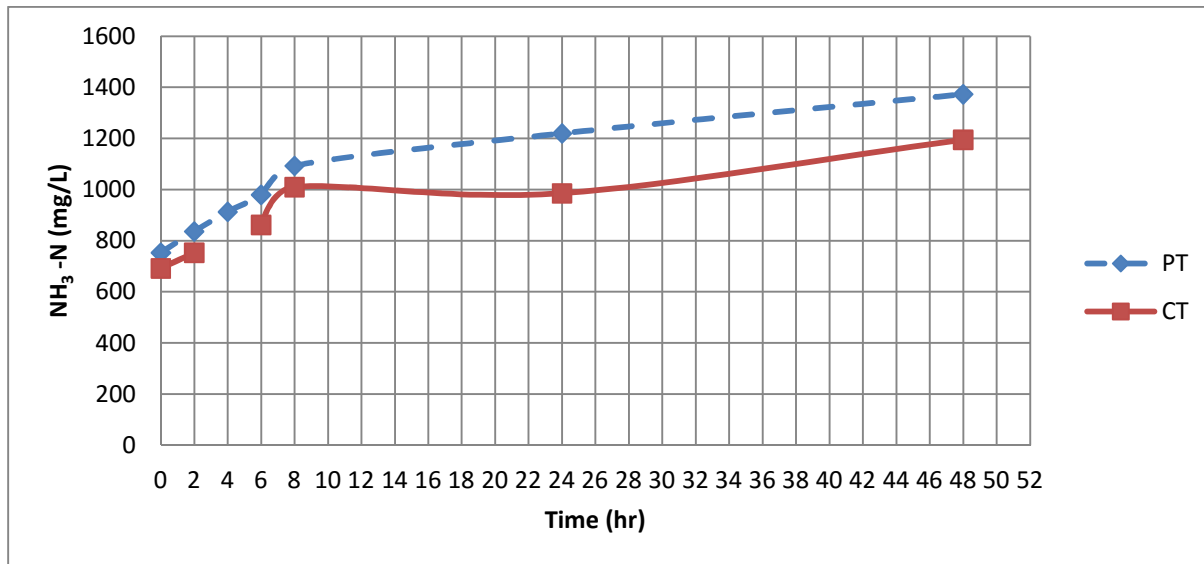

Figure 4.30: NH₃-N concentrations in Phase-3 dynamic test.

The production of VFAs was employed as an indication of fermentation inside the bottles with a lower substrate to inoculums ratio to better observe the VFA composition and rate changes as a result of fermentation. Figures 4.31 and 4.32 demonstrate the TVFA and VFA concentrations in the digesters for Phase-3. The increases of TVFA in the control and pretreated digesters between 0 to 12 hours were 49% and 26% respectively. However, the amount of TVFA generated in the pretreated digester (12230 mg COD/L) was higher than the TVFA generated in the control digester at 48 hours (9065 mg COD/L). The higher VFA values were attributed to the high sCOD values generated in the pretreatment. The overall increase of TVFA (compared to TVFA obtained from raw TWAS) in the control and pretreated digesters were 1.56 and 2.1 fold respectively. Thus, pretreatment generated more TVFA in the pretreated digester compared to the control digester.

The speciation of the VFAs was assessed since it would impact upon their availability to methanogens in the later stage. In this Phase, Propionic acid had the highest concentrations in the control followed by acetic acid and butyric acid whereas; acetic acid had the highest concentrations in the pretreated followed by propionic acid and butyric acid. The composition of the VFAs in the pretreated digester were different in Phase -3 as compared to Phases 1 & 2. Unlike the other Phases acetic acid was the dominant VFA. Thus, the pretreated digester produced more readily biodegradable compounds and this pattern could impact the pretreated digester in later methanogenic process as acetic acid was the simplest form of VFA to convert into methane.

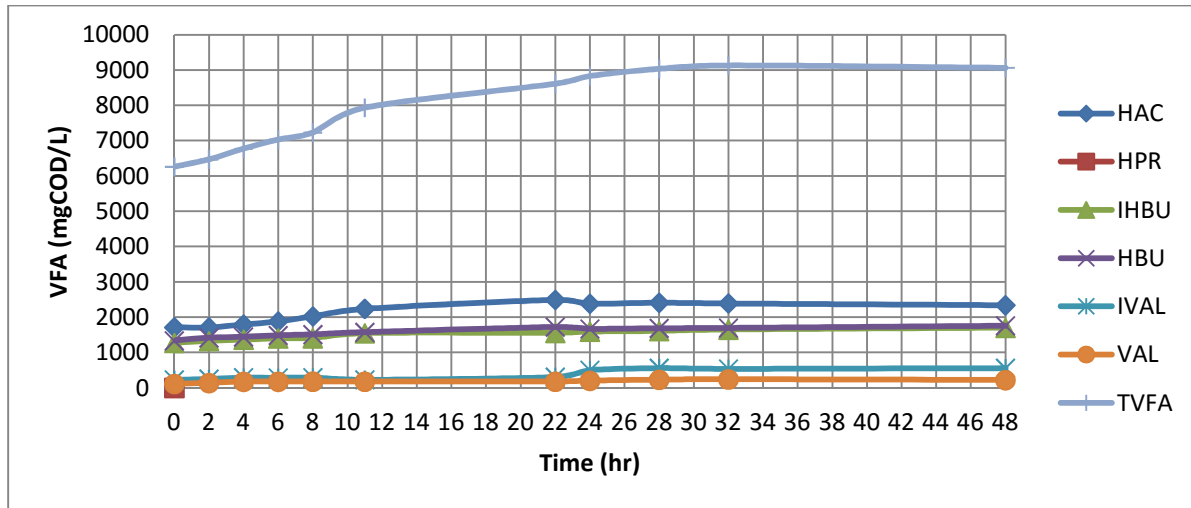

Figure 4.31: VFAs in control bottle for Phase-3 dynamic test.

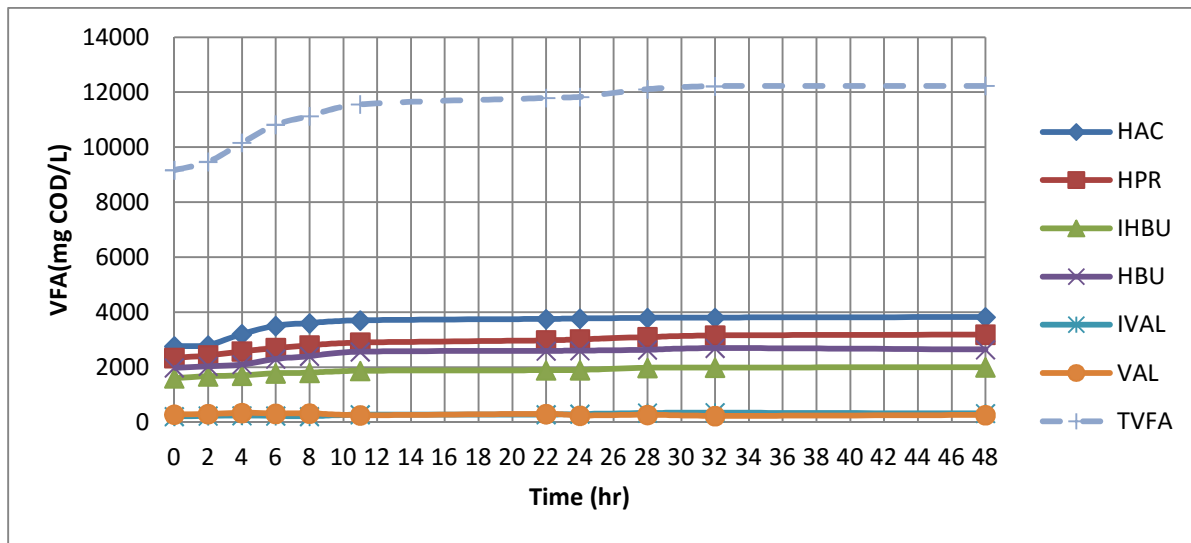

Figure 4.32: VFAs in the pretreated bottle for Phase-3 dynamic test.

4.3.2.4 Summary of Batch Tests

A brief summary of all the responses in each phase of the dynamic tests was generated to provide an overall evaluation of the effect of PT on acid phase digestion and will be explained in this section.

Compared to the pre-treated acid phase digester, the control digester showed an increased rate of sCOD production, VSS destruction, and ammonia generation. However, the final amounts of solubilisation and

fermentative products were higher in the pretreated digester compared to the control despite the reduced rates.

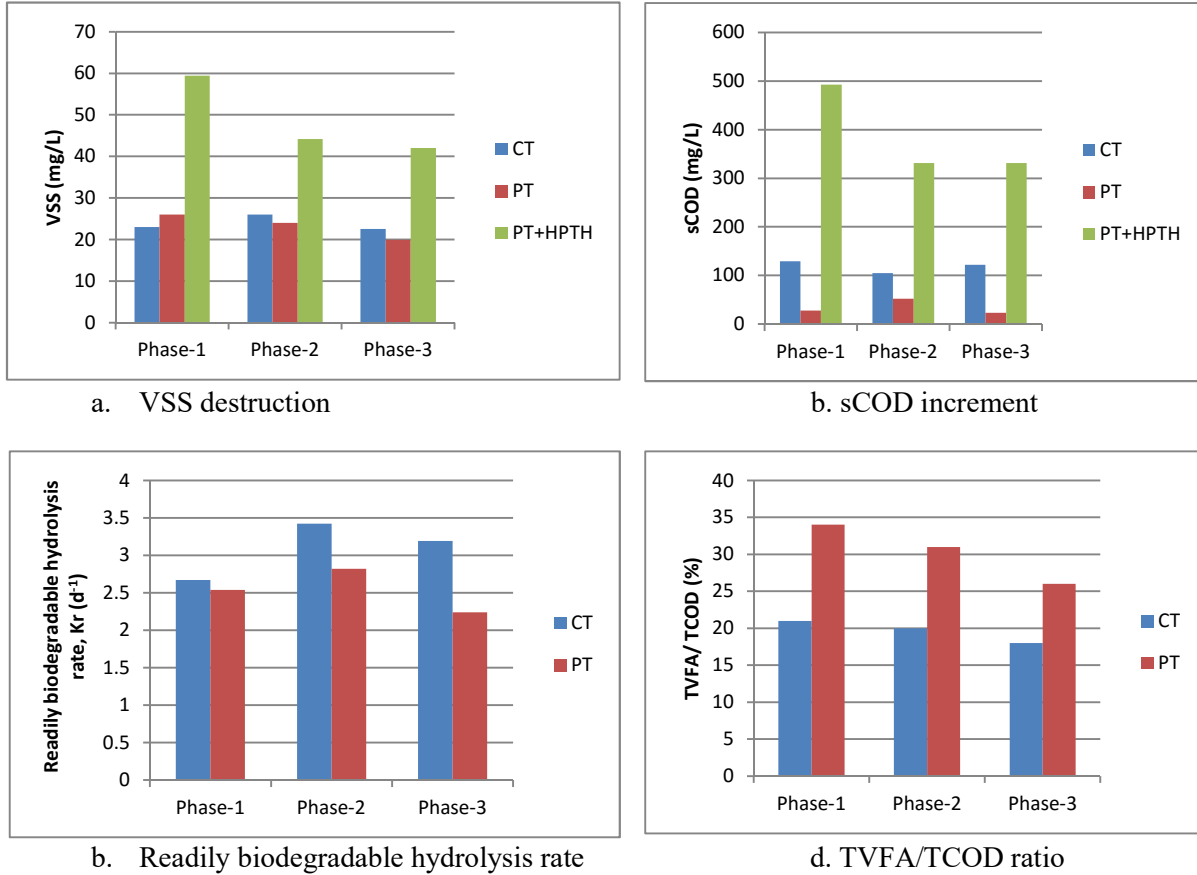

Figure 4.33: Comparison among phases in dynamic test.

The VSS destructions observed throughout the operation of the acidogenic digesters and the overall destruction as a result of HPTH is shown in Figure 4.33. As can be seen from the figure, in all Phases VSS destruction was almost the same in both digester and thus differences could be considered negligible. However, the combined effect of the pretreatment stage increased VSS destruction in the pretreated digester and the effect was observed in the individual time series graphs in the previous section. As a result of the pretreatment stage the total VSS destruction in the pretreated acidogenic phase digester for phases 1, 2 & 3 were 59%, 44%, 42% respectively and the control digesters were 23%, 26%, 23% respectively.

Similar responses were observed in the sCOD production and as seen from Figure 4.33, the digester-only sCOD increment was higher (53-100%) in the control compared to the pretreatment in all stages. However, the total increase of sCOD in phases 1, 2 & 3 were 492%, 331%, 332% respectively and the control digesters were 129%, 105%, 122% respectively. Despite the higher hydrolysis rate observed in the control digester (average of three phase was 3.09 d^{-1}) compared to the pretreated digester (average of three phase was 2.53 d^{-1}) as shown in Figure-4.33 c., more solubilised products generated in the pretreated digester as a result of previous pretreatment stage. Thus, the HPTH of TWAS led to the increase in availability of substrate to microorganisms and conversion of non-biodegradable COD into biodegradable materials, thus resulting in greater sCOD and VSS destructions.

As shown in Figure 4.33, higher fermentation occurred in the pretreated digester as compared to the control. In order to compare the fermentation among Phases the ratio of TVFA to TCOD was assessed and as seen from Figure-33, the pretreated digester obtained a higher (8-13%) ratio than the control digester. However, for the pretreated digester only 26–34% of the influent TCOD was converted to TVFA and it was lower (18-21%) for the control digester. The possible reason could be the acidogenic bacteria could have been affected and inhibited at the highest organic loading rate of the substrate and resulted in lower acidification.

The overall observation for all the time series graphs shows most of the hydrolysis and fermentation activities occurred within 0 to 12 hours. Also, the solubilised and fermented products obtained from the control digester produced within or before 12 hours in the pretreated digester. As a result, System-2 was operated with 1 day HRT and it was assumed to produce same amount of hydrolysis and fermentation as 2 day HRT and thus will be preferred for methane generation in the later stage.

4.4 Methanogenic Phase Performance

The second stage in the HPTH+2PAD CSTR process was the methanogenic phase. It was expected that in this phase the readily biodegradable products would be utilized by the microbial population and methane would be produced. All the other parameters such as solids, CODs and VFAs were expected to be further reduced in the methanogenic phase. However, it was expected that ammonia would increase due to solubilisation and TKN was expected to be reserved throughout the process. Digester stability is an important factor in the methanogenic phase. In this section these properties of the control and pretreated

digesters in three different phases will be discussed. Systems 1 & 2 were operated as two phased digesters whereas System-3 was operated as a single phased digester.

4.4.1 Stability of the Digesters

As previously described the biodegradability of the TWAS was increased as a result of HPTH pretreatment and hence stability with respect to pH excursions was a potential operational concern under the shorter HRTs (10 to 15 day) employed in this study. The stability of the digesters was evaluated in terms of pH, alkalinity, VFAs and sCOD. The result presented consist of the steady state period except for the pH result. It is important to maintain the pH close to neutral values in the methanogenic digester to avoid any accumulation of VFAs inside the digester (Maspolim et al., 2015). From Table 4.12 it can be observed that the pH in the digesters was in the range of 7.1-7.4 for all the Systems. The alkalinity in the digesters was in the range of 3500-5000 mg CaCO₃/L and the VFAs were between 90-560 mg/L for all the Systems. Similar ranges of alkalinity and VFA have been reported to be indicative of stable conditions (Dareioti & Kornaros, 2014; Ganesh et al., 2014; Maspolim et al., 2015). The VFA to alkalinity ratio, α is strong indicator of digester stability and a value less than 0.2 indicates a stable operating condition (Rittmann & McCarty, 2012). In this study the ratio, α varied from 0.02-0.14 and was below the threshold value indicating a stable system. The value of α also varied with the increasing OLR among Systems. The lowest OLR was in System-1 ranging from 1.78-2.01 kg VSS/ m³d and as a result the value of α was .02-.03. System-3 had higher OLR than System-1, ranging from 2.4-2.94 kg VSS/ m³d and the α was 0.11-0.13. The highest OLR was observed in System-2 ranging from 2.91-3.41 kg VSS/ m³d and α varied from 0.1-0.14. The trend in the VFA to alkalinity ratio (.02-0.14) confirmed the stability is related to the OLR. To conclude, the OLR provided in the Systems resulted in stable conditions for methanogenic activity. The use of pretreatment and acid phase digestion that increased the biodegradability of the WAS did not result in the stability of the methanogenic digesters being compromised.

Table 4-12: Stability parameters for the Methanogenic phase digesters

Parameter	Unit	System-1		System-2		System-3	
		CT	PT	CT	PT	CT	PT
Alkalinity	mg as CaCO ₃ /L	4380±270 (10,3)	4560±260 (10,3)	3630±210 (6,1)	4850±160 (6,1)	3860±500 (6,3)	5110±280 (6,3)
sCOD	mg/L	1620±580 (17,3)	1820±720 (17,3)	1120±400 (10,3)	1530±440 (10,3)	2960±700 (10,3)	3130±690 (10,3)
TVFA	mg COD/L	120±30 (6,3)	90±20 (6,3)	500±30 (10,3)	500±25 (10,3)	480±110 (6,3)	560±120 (6,3)
pH	NA	7.4±.15 (100,1)	7.4±.13 (100,1)	7.3±.05 (30,1)	7.4±.04 (30,1)	7.1±.11 (15,1)	7.2±.08 (15,1)
TVFA/Alkalinity	NA	0.03	0.02	0.14	0.1	0.13	0.11
OLR	kg VSS/ m ³ d	2.01	1.78	3.41	2.91	2.94	2.45

4.4.2 Comparison of Biogas Production and Methane Yield Among Systems

It was expected that in the methanogenic reactor biodegradable COD would be consumed by methanogens to produce methane along with other biogas components. The methane production will be discussed in this section and a comparison will be made between the control and pretreated digesters of each system and among three systems. Any additional methane produced in the pretreated digester was attributed to sCOD generated in the pretreatment and acidogenic stages.

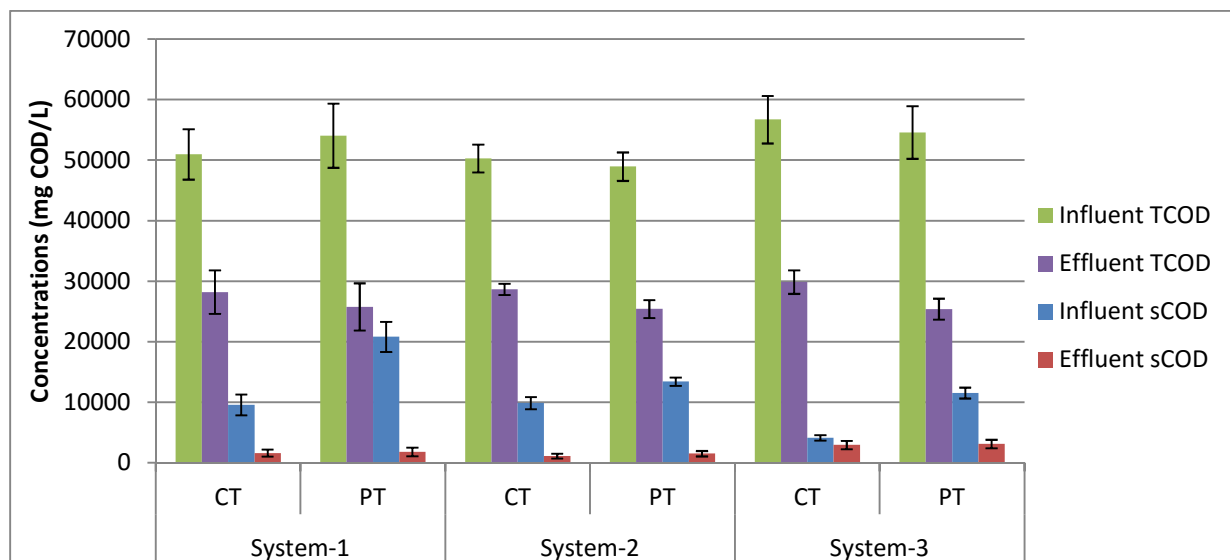

Figure 4.34: COD concentrations in the methanogenic phase of the Systems.

For System 1 & 2 the TCOD added to the methanogenic digesters was obtained from the effluent TCOD of acidogenic phase digester whereas; for System-3 the feed consisted of either raw TWAS or PTWAS. Figure 4.34 presents the COD concentrations for the control and the pretreated digesters in all the Systems. In System-1, the TCOD decreased from 54050 to 25780 mg/L and 50970 to 28210 mg/L for the control and pretreated digesters respectively. Hence, removal efficiencies of 45% in the control and 52% in the pretreated digester were determined. The TCOD decreased from 50294 to 28680 mg/L and 48945 to 25420 mg/L for the control and PT pretreated digesters respectively, which yielded removal efficiencies of 43% in and 48% in the respective digesters in System-2. Finally, in System-3, the TCOD decreased from 56700 to 29880 mg/L and 54590 to 25410 mg/L for the control and pretreated digesters respectively. This resulted in removal efficiencies of 47% and 53% respectively. From the removal efficiencies it was concluded that TCOD removal efficiency decreased for both digesters in System-2 with decreasing HRT. System-1 & 3 had same 13 day HRT in the methanogenic digester and negligible difference of TCOD removal efficiency was observed between these two Systems. However, in all the Systems the pretreated digester achieved higher (5 to 7%) TCOD removal compared to the control digesters. The pretreatment generated soluble biodegradable products as discussed in section 4.1.1 in the BMP test result which contributed to rapid fermentation. Thus, more readily biodegradable products were available in the pretreated digesters as compared to the control digesters. Also, lower HRT reduced the TCOD removal efficiency as observed in System-2 which had a 9 day HRT in the methanogenic phase compared to 13 days in the other two systems.

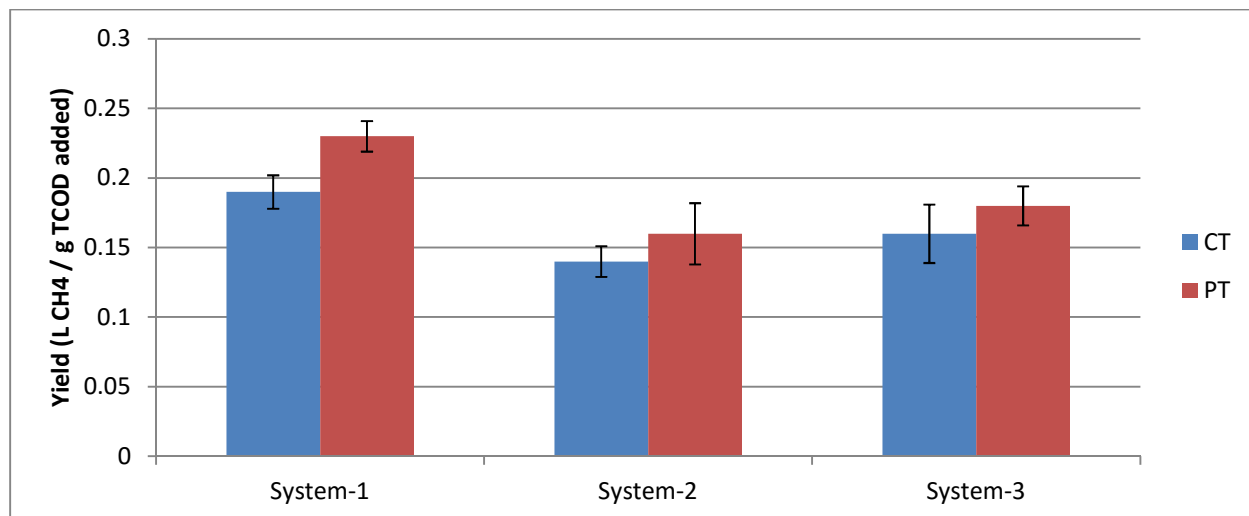

Figure 4.35: Methane Yield in all systems for TCOD added.

The organic loading rates were different among the systems and as a result the use TCOD removal was not a definite indication of a System's efficiency and hence methane yields were evaluated. The methane yield was calculated for the TCOD added to each digester in all Systems. Figure-4.35 shows the methane yields calculated for TCOD added to the digesters for all three Systems. The TCOD removed by each System and individual digesters could also be calculated from this yield values from the standard methane yield of 0.395 L CH₄/ g TCOD removed at 37^oC.

The TCOD removal efficiencies obtained from the lab test and from the theoretical methane yield calculation were compared to evaluate the validity of the yield values. In System-1, the pretreated yield was 0.23 L CH₄/ g TCOD added for the control and 0.19 L CH₄/ g TCOD added for the pretreated digester and the removal efficiencies were 48% and 58% in the control and pretreated digester respectively. The difference between the theoretical TCOD removal efficiency and efficiency obtained from the yield value was less than 6%. For System-2, the pretreated and control yields were 0.16 and 0.17 L CH₄/ g TCOD added; according to the standard methane yield, the removal efficiencies were 40% and 43% in the control and pretreated digester respectively. The removal efficiency from the yield values was slightly higher than that calculated from the TCOD of the digesters. However, the difference was less than 5%, which was deemed to be negligible. For System-3, the pretreated yield was 0.2 L CH₄/ g TCOD added for the control and 0.15 L CH₄/ g TCOD added for the pretreated digester; according to the standard methane yield, the removal efficiencies were 40% and 50% in the control and pretreated digester

respectively. The removal efficiencies from the yields were less than the removal efficiency calculated from the TCOD of the digesters but the difference was less than 7%. To conclude, the TCOD removal efficiency calculated from two different methods were similar and contained an error of less than 7% in all of them which is negligible. Thus, the yield values obtained were deemed to be reliable for comparing the efficiency among the three systems.

As previously described the methane yields were consistently higher (13 to 21 % higher compared to the control methane yield) in the pretreated digester for all the systems. The results suggest that the generation of sCOD as a result of pretreatment was responsible for the improved performance. Moreover, acid phase generated higher TVFAs (5 % higher in System-1 and 36% higher in System-2) in the pretreated digester compared to the control. The sCOD values entered as feed to the methanogenic digesters can be found in Figure-4.7 a & b. The influent sCOD for the methanogenic digesters were the effluent sCOD obtained from the acidogenic digesters. The additional sCOD (obtained from the difference of pretreated and control digesters sCOD) generated in the pretreated digester was multiplied with the flow rate and the theoretical methane yield (at 37 °C= .395 L CH₄/ g COD) to get the equivalent methane of the sCOD. The rationale of higher methane production rate observed in the pretreated methanogenic digester as a result of hydrolysis in the pretreatment stage and additional hydrolysis with fermentation occurred in the acidogenic phase digesters in each System has been discussed below.

System-1 was operated for 13 day HRT in the methanogenic phase and the methane production rate in the pretreated digester was 5 L CH₄/d higher (30% increase) than the control digester. This increase in methane production rate was observed in the theoretical methane equivalent from the increment in SCOD in the influent of the pretreated digester compared to the control digester. The differences in the SCOD in the influent was approximately 11 g/L with a feed flow rate of 1.5 L/d, which was equivalent to about 6.5 L CH₄/d. The difference of 1.5 L CH₄/d in the methane production rate occurred as a result of only 41% TVFAs in the sCOD of the pretreated digester in the influent. Another explanation was, despite of consumption of a major portion (91%) of sCOD by the biomass remaining sCOD was found in the effluent and could be considered as non- biodegradable sCOD. Thus, all the biodegradable CODs generated as a result of hydrolysis and fermentations were effectively utilized by the biomass and converted to methane.

System-2 was operated with a 9 day HRT and the pretreated digester produced additional 1 L CH₄/d than the control digester which represented an 8% increase. Whereas, the difference of influent sCOD in between the control and pretreated was 3.5 g/L with a flow rate of 1.5 L/d, theoretically should generate a difference of 2 L CH₄/d. In this System, the TVFA constituted 52% TVFA in the sCOD of the effluent in the pretreated acidogenic digester. Despite of producing higher (11% more compared to System-1) percentage of TVFA, only a certain portion was utilized by the biomass in the pretreated methanogenic phase digester. Moreover, the non-biodegradable sCOD was higher compared to System-1 and 88% of influent sCOD was utilized by the biomass. This could also be due to shorter HRT in this system compared to the other two Systems. To conclude, despite of higher fermentation in the acidogenic phase, the methanogenic phase was unable to utilize all the viable COD generated.

System-3 was a single phased AD and as a result TVFA after fermentation inside the digester could not be determined. The additional 3 L CH₄/d generated in the pretreated digester was less than the theoretical methane production rate achieved from the influent sCOD difference in between the control and pretreated digester. The difference of influent sCOD in between the control and pretreated was 7.6 g/L with a flow rate of 1.5 L/d. According to the theoretical calculation, the methane production rate should have been 4.5 L CH₄/d. the deficiency of 1.5 L CH₄/d occurred because unlike the two stage systems only 77% of the influent sCOD was consumed by the biomass and rest of the sCOD remained unused and contributed as the non-biodegradable COD in the effluent. Thus, the acidogenic phase along with pretreatment was capable of producing more readily biodegradable products in System-1 & 2 compared to only single stage in System-3.

To conclude, comparing the methane yields for the three Systems it was found that the TCOD removal efficiency was always higher (5-7%) in the pretreated system compared to the control. Among the three systems, System-1 had higher COD removal efficiency followed by System-3 & System-2. The methane production rate was also higher in System-1 followed by System-3 & System-2. Hence, the effect of reducing HRT was observed here. The methane yield and production were also reduced with the reduction of HRT. However, in Systems-2& 3 similar yields of 0.16 L CH₄/ g TCOD added were found for the pretreated digester in two stage with 10 day HRT and in the control digester of single stage with 13 day HRT. Thus, with pretreatment and two stages operation similar yield can be achieved with reduction of 3 days in the HRT.

4.5 Overall Removal Efficiencies

The overall removal efficiencies of the three Systems operated in this study will be discussed in this section in terms of solids and TCOD removal. Also, the final concentrations of ammonia and TSS concentrations will be presented. A comparison will be made between Systems 1 & 2 to assess whether reduced HRT (from 15 day to 10 day) in the two stage systems impacted the removal of solids and COD. Systems 1 & 3 will be compared because both systems had same 13 day HRT in methanogenic phase. All the removal efficiencies were calculated on the basis of the raw TWAS & PS concentrations and final effluent values from the digesters.

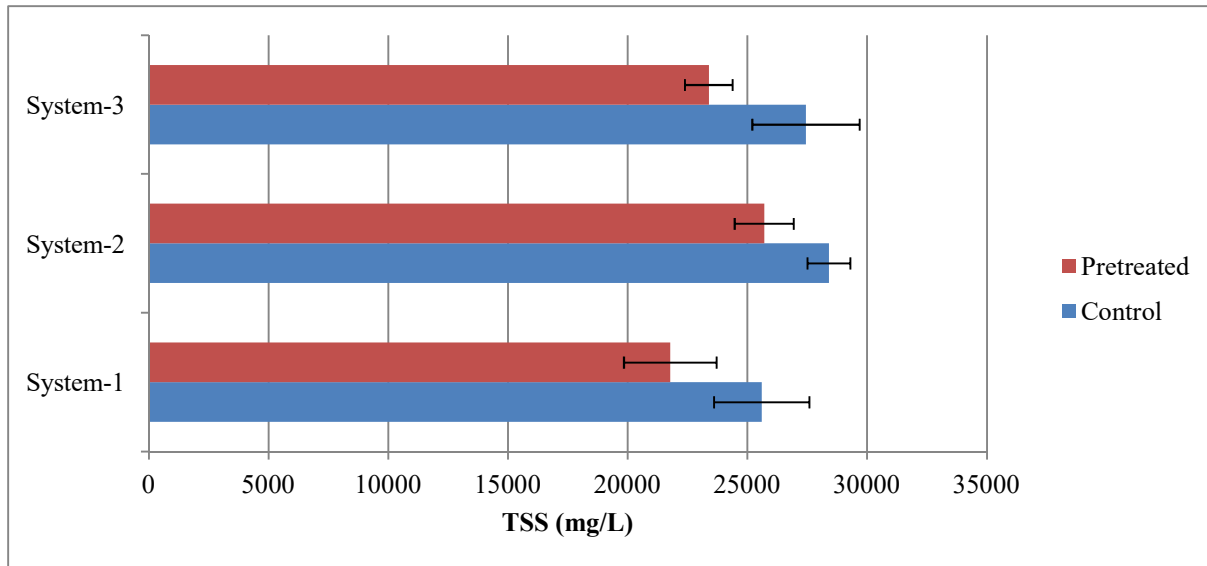

Figure 4.36: Final TSS concentration in all Systems.

The removal efficiency of TSS in the Systems may not provide conclusive data on overall removal of organic solids, but the gathered final concentrations from the effluent of the digesters may provide some substantial information on solid reduction. Figure 4.36 shows the final TSS concentrations in the control and pretreated digesters of all three systems. For both digesters System-1 with the highest HRT (15 day) was capable of achieving the lowest TSS concentrations (25600±1990 mg/L in the control and 21780±1930 mg/L in the pretreated digester) compared to other two Systems. System-3 which was a single stage system with 13 day HRT had the second lowest TSS concentrations. The highest TSS concentrations were observed in System-2 with the lowest HRT of 10 day containing 28400±900 mg/L in the control and 25700±1230 mg/L in the pretreated digester. The results obtained were consistent with HRT and the System-1 was capable of removing additional TSS as a result of PT stage and acidogenic stage.

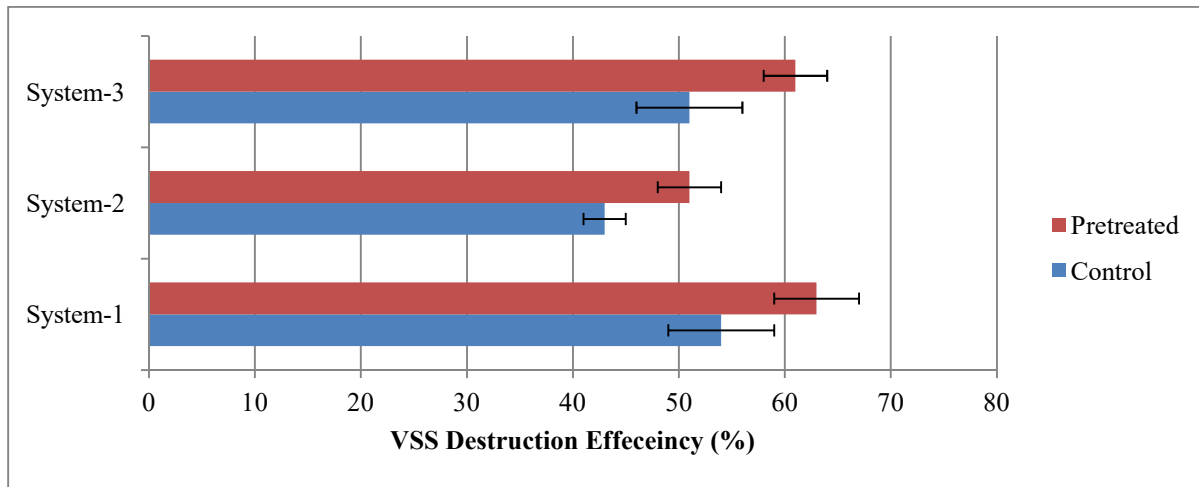

Figure 4.37: Overall VSS destruction in all Systems.

The removal of VSS indicates solubilisation and destruction of particulate organic matter. Noticeable amount of VSS destruction was observed in the pretreatment process. In addition the acidification stage also contributed to hydrolysis which reduced the VSS further. Figure 4.37 presents the VSS removal efficiencies in the digesters for all three Systems. From the graph it can be observed that System-1 had the highest VSS removal efficiency (54% in the control and 63% in the pretreated) compared to other two systems. System-3 with the same methanogenic HRT of 13 day achieved 51% destruction in the control and 61% destruction in the pretreated digester. Thus, a two stage system along with pretreatment was capable of reducing additional 12% VSS, implying PT and acidogenic phase was capable of more hydrolysis than a single stage digester.

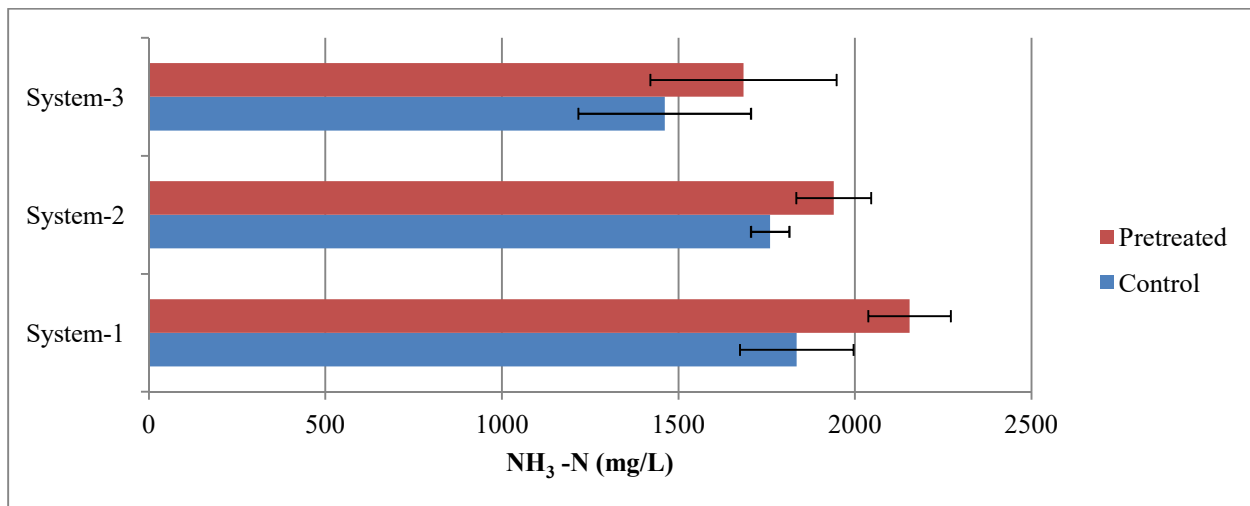

Figure 4.38: Final ammonia concentrations in all Systems.

Ammonia is a parameter of interest because of its potential to inhibit anaerobic system if the threshold value (3000mg/L) is exceeded. Ammonia was expected to increase due to hydrolysis and fermentation of proteins within the digester that releases ammonia from amino acids. In the two stage system both hydrolysis and fermentation occurred in a separate acidogenic stage and thus more ammonia release was expected in two stage system. Figure 4.38 presents the final ammonia concentrations in the digesters in all three Systems. The highest final ammonia concentration was observed in System-1 with 1280 ± 120 mg/L in the control and 1500 ± 90 mg/L in the pretreated digester. As mentioned earlier, due to two stage operating condition, System-2 showed the second highest ammonia concentrations with 1760 ± 50 mg/L in the control and 1940 ± 100 mg/L in the pretreated digester. The lowest final ammonia concentration was found in the single stage operated System-3 with 1460 ± 240 mg/L in the control and 1680 ± 260 mg/L in the pretreated digester. In all systems the pretreated digester released more ammonia compared to the control digester. However, none of the ammonia concentrations exceeded the threshold value and thus the digesters were not inhibited.

To conclude, the pretreatment stage was capable of rapid hydrolysis which was observed with ammonia release in the digesters as well as VSS destruction that was consistently higher in all the pretreated digesters in both single stage and two stage systems. Also, the pretreated digesters were capable of reducing TSS compared to the control digesters and hence there was greater overall sludge reduction.

Chapter 5 - Conclusion

This study was designed to evaluate the impacts of HPTH pretreatment as a separate stage ahead of a two digestion process and this sequence was compared against single stage operation. The entire experiment was designed in three Systems and each system had parallel digesters fed with raw and pretreated TWAS to observe the effect of pretreatment on digestion. It was found that HPTH at 150⁰ C and 3 bars for 30 minutes increased the solubilisation of TWAS to create biodegradable COD. This biodegradable COD was further hydrolysed and acidified in the acidogenic stage and produced more readily biodegradable products in form of VFAs to be consumed by methanogens in the methanogenic reactor in order to produce more methane. The conclusions obtained from the experiment are summarized below.

- The HPTH pretreatment increased solubilisation of TWAS by 25-34%. No significant accumulation of VFA was noticed and less than 2% increase of ammonia (as a fraction of TKN) was noticed which was also negligible. The average destruction of TSS and VSS was 28% and 34% respectively. No significant change in TCOD, VFA and ammonia indicates pretreatment only solubilised particulate materials and no loss of valuable resources for methane generation was compromised. Thus, thermal pretreatment positively affected the solubilisation of organics in the TWAS. HPTH with higher temperature and longer duration were beneficial to the solubilisation of particulate matters and accelerated the production of methane in the following high-solid anaerobic digestion.
- BMP testing was conducted on raw samples individually and in various combinations. The methane yield (L CH₄ / L substrate added) showed a 34% increase when only TWAS was pretreated and only a 6% increase when only PS was pretreated. Therefore, pretreatment was conducted on TWAS and a co-digestion was accomplished while feeding the digesters with TWAS/PTWAS & PS. The biodegradability increased 16% in the PTWAS compared to the TWAS, concluding pretreatment generated biodegradable products.
- During the operation period the acidogenic phase maintained a pH around 5.5 and no chemical addition was required to maintain pH. However, in the dynamic test the acidogenic digesters required pH adjustment because only TWAS/PTWAS was employed as the feed. As a result, co-digestion of PS along with TWAS/PTWAS was capable of maintaining the desired pH for acidogenic phase.
- The hydrolysis rate constant showed the control digester hydrolysed 50% more slowly hydrolysable particulates than the pretreated digester. The readily biodegradable hydrolysis

constant was also high (17% in Phase-1 & 30% in Phase-2) in the control digester. However, the overall increment of VFA and sCOD was higher in the pretreated digester because of the previous pretreatment stage. As pretreatment solubilised a major portion of particulates only a minor portion was available to be hydrolysed in the acidogenic phase. Thus, pretreatment produced 16% more biodegradable compounds and they were further hydrolysed and fermented in the acidogenic stage but at a slower rate.

- The pretreated digesters increased the methane yields by 21%, 14% and 13% respectively compared to the control digester in System 1, 2 & 3. Hence, pretreatment was always capable of producing more methane compared to control digester.
- System-1 & 3 was operated with 13 day HRT in the methanogenic phase. System-1 achieved 43% more methane yield compared to single stage System-3, increasing from 0.16 to 0.23 L CH₄/g TCOD added. Consequently, two stage phased anaerobic digestion with pretreatment was capable of producing higher methane compared to single stage with no pretreatment.
- While comparing between the two stages systems, Systems-2& 3 similar yields of 0.16 L CH₄/ g TCOD added were found for the pretreated digester in two stages with 10 day HRT and in the control digester of single stage with 13 day HRT. Therefore, with pretreatment and two stages operation HRT could be reduced to 10 days from 13 days.

To conclude, the implementation of the HPTH pretreatment ahead of two stage CSTR system was successful to generate more methane, reduced solids than the single stage system and control digester. Despite of slower hydrolysis rate in the acidogenic phase the pretreatment was capable of more hydrolysis and fermentation. The readily biodegradable products were consumed by the methanogens to produce higher methane than the control digester with reduced HRT.

Chapter 6- Recommendation

The results of this research suggested thermal pretreatment ahead of anaerobic digestion achieved higher methane production and splitting the digestion system in two stages was a success. Based on the findings in this current research some other future works are suggested below.

- Thermal pretreatment requires energy and finding the optimum condition for the pretreatment of a particular sludge is crucial. The effect of thermal pretreatment depends upon the raw characteristics of the sludge and thus a number of conditions should be applied before deciding the optimum temperature and duration.
- The ratio of co-digestion also impacts the performance of the anaerobic digestion. As a result the ratio of PS and TWAS/PTWAS need to be changed to achieve the optimum digestion results.
- While operating a comparative study with raw and pretreated sludge, it is recommended for (1 to 2 weeks) both digesters need to be fed with raw TWAS in order to enrich micro-organisms as well as to confirm the performance of the both digesters. Then, the reactors should be separately fed with TWAS and PTWAS.
- The dynamic tests showed different values for the increment of sCOD and ammonia. As a result other components such as the lipids and carbohydrate increase rate also need to be determined.
- To investigate the hydrolysis mechanism in the acidogenic phase a dual hydrolysis model was utilized. The dual hydrolysis model contained two first-order equations and is still simplistic in describing hydrolysis process in a phased digestion system. A more complex model considering the biomass concentration will be more accurate to describe the hydrolysis process.
- Investigation of the impacts of other pretreatment techniques such as sonication, ozonation, chemical addition, etc., may be considered to observe the impact in two stage anaerobic digestion system.
- Maintaining two stage anaerobic digestion is difficult and the application of thermal treatment could be economically viable. As a result, it was necessary to estimate the costs due to pretreatment and maintenance of two separate digesters for phased digestion.

References

- Ahring, Birgitte K., Ashraf A. Ibrahim, and Zuzana Mladenovska. 2001. "Effect of Temperature Increase from 55 to 65°C on Performance and Microbial Population Dynamics of an Anaerobic Reactor Treating Cattle Manure." *Water Research* 35 (10): 2446-2452.
- Anderson, G. K., B. Kasapgil, and O. Ince. 1994. "Microbiological Study of Two-Stage Anaerobic Digestion during Start-Up." *Water Research* 28 (11): 2383-2392.
- Bialek, Katarzyna, Denise Cysneiros, and Vincent O'Flaherty. 2014. "Hydrolysis, Acidification and Methanogenesis during Low-Temperature Anaerobic Digestion of Dilute Dairy Wastewater in an Inverted Fluidised Bioreactor." *Applied Microbiology and Biotechnology* 98 (20): 8737-8750.
- Batstone, D. J., J. Keller, I. Angelidaki, S. V. Kalyuzhnyi, S. G. Pavlostathis, A. Rozzi, W. T. Sanders, H. Siegrist, and V. A. Vavilin. 2002. "The IWA Anaerobic Digestion Model no 1 (ADM1)." *Water Science and Technology* 45 (10): 65-73.
- Bhattacharya, Sanjoy K., Richard L. Madura, David A. Walling, and Joseph B. Farrell, 1996:. "Volatile solids reduction in two-phase and conventional anaerobic sludge digestion." *Water Research* 30, no. 5 :1041-1048.
- Blumensaat, F. and J. Keller. 2005. "Modelling of Two-Stage Anaerobic Digestion using the IWA Anaerobic Digestion Model no. 1 (ADM1)." *Water Research* 39 (1): 171-183.
- Bougrier, C., J. P. Delgenes, and H. Carrere. 2006. "Combination of Thermal Treatments and Anaerobic Digestion to Reduce Sewage Sludge Quantity and Improve Biogas Yield." *Process Safety and Environmental Protection* 84 (4): 280-284.
- Bolzonella, D., Cavinato, C., Fatone, F., Pavan, P., & Cecchi, F. , 2012. "High rate mesophilic, thermophilic, and temperature phased anaerobic digestion of waste activated sludge: A pilot scale study ". *Waste management*, 32(6), 1196-1201.
- Burger, Gillian and Wayne Parker. 2013. "Investigation of the Impacts of Thermal Pretreatment on Waste Activated Sludge and Development of a Pretreatment Model." *Water Research* 47 (14): 5245-5256.
- Burger, G. . (2012). "Investigation of the Impacts of hermal Activated ludge Pretreatment and Development of a Pretreatment Model." Masters hesis, University of Waterloo, Canada.
- Carrère, Hélène, Claire Bougrier, Delphine Castets, and Jean Philippe Delgenès. 2008. "Impact of Initial Biodegradability on Sludge Anaerobic Digestion Enhancement by Thermal Pretreatment." *Journal of Environmental Science and Health, Part A* 43 (13): 1551-1555.
- Chauzy, J., Cretenot, D., Bausseon, A., D. . (2007). "Anaerobic Digestion Enhanced by Thermal Hydrolysis: First Reference BIOTHELYS® at Saumur, France. Facing Sludge Diversities: Challenges, Risks and Opportunities." Antalya, Turkey

- Climent, M., I. Ferrer, M. d. M. Baeza, A. Artola, F. Vazquez, and X. Font. 2007. "Effects of Thermal and Mechanical Pretreatments of Secondary Sludge on Biogas Production Under Thermophilic Conditions." *Chemical Engineering Journal* 133 (1-3): 335-342.
- Dareioti, M. A. and M. Kornaros. 2014. "Effect of Hydraulic Retention Time (HRT) on the Anaerobic Co-Digestion of Agro-Industrial Wastes in a Two-Stage CSTR System." *Bioresource Technology* 167: 407-415.
- Donoso-Bravo, A., S. Pérez-Elvira, E. Aymerich, and F. Fdz-Polanco. 2011. "Assessment of the Influence of Thermal Pre-Treatment Time on the Macromolecular Composition and Anaerobic Biodegradability of Sewage Sludge." *Bioresource Technology* 102 (2): 660-666.
- Donoso-Bravo, A., S. Pérez-Elvira, and F. Fdz-Polanco. 2015. "Simplified Mechanistic Model for the Two-Stage Anaerobic Degradation of Sewage Sludge." *Environmental Technology (United Kingdom)* 36 (10): 1334-1346.
- Dwyer, J., D. Starrenburg, S. Tait, K. Barr, D. J. Batstone, and P. Lant. 2008. "Decreasing Activated Sludge Thermal Hydrolysis Temperature Reduces Product Colour, Without Decreasing Degradability". *Water Res.* 42:4699-4709.
- Eastman, J. A. and J. F. Ferguson. 1981. "Solubilization of Particulate Organic Carbon during the Acid Phase of Anaerobic Digestion." *Journal of the Water Pollution Control Federation* 53 (3): 352-366.
- Elbeshbishy, E., G. Nakhla, and H. Hafez. 2012. "Biochemical Methane Potential (BMP) of Food Waste and Primary Sludge: Influence of Inoculum Pre-Incubation and Inoculum Source." *Bioresource Technology* 110: 18-25.
- Elefsiniotis, Panagiotis, and William K. Oldham. 1994. "Anaerobic acidogenesis of primary sludge: the role of solids retention time." *Biotechnology and bioengineering* 44, no. 1 7-13.
- Fernandez-Polanco, F., Velazquez, R., Perez-Elvira, S.I., Casas, C., Del, B. D., Cantero, F.J., Fernandez-Polanco, M.; Rodriguez, P.; Panizo, L.; Serrat, J. and Rouge, P. (2008). "Continuous thermal hydrolysis and energy integration in sludge anaerobic digestion plants." *Water Science and Technology*, 57 (8), 1221-1226.
- Ferrer, J., J. J. Morenilla, A. Bouzas, and F. García-Usach. 2004. *Calibration and Simulation of Two Large Wastewater Treatment Plants Operated for Nutrient Removal*. Vol. 50.
- Ganesh, R., M. Torrijos, P. Sousbie, A. Lugardon, J. P. Steyer, and J. P. Delgenes. 2014. "Single-Phase and Two-Phase Anaerobic Digestion of Fruit and Vegetable Waste: Comparison of Start-Up, Reactor Stability and Process Performance." *Waste Management* 34 (5): 875-885.

- Gavala, H., Yenal, U., Skiada, I., Westermann, P., and Ahring, B. (2003). "Mesophilic and thermophilic digestion of primary and secondary sludge. Effect of pre-treatment and elevated temperature ". *Water Research*, 37(19): 4561-4572
- Ge, H., Jensen, P. D., and Batstone, D. J. (2010) " Temperature phased anaerobic digestion increases apparent hydrolysis rate for waste activated sludge" . *Water Research*, 45(4), 1597-1606.
- Gurieff, N., J. Bruss, S. Hoejsgaard, J. Boyd, and M. Kline. 2011. "Maximizing Energy Efficiency and Biogas Production: EXELYS – Continuous Thermal Hydrolysis". *Proceedings of the WEFTEC Conference*, Los Angeles, California, October.
- Gujer, W., and A. J. B. Zehnder. "Conversion processes in anaerobic digestion." *Water Science & Technology* 15, no. 8-9 (1983): 127-167.
- Han, Y., Shihwu, S. and Dague, R.R. (1997) "Temperature-phased anaerobic digestion of wastewater sludges". *Water Science and Technology*, 36(6-7): 367-374
- Henze, M., M.C.M. van Loosdrecht, G.A. Ekama, and D. Brdjanovic. 2008. Biological Wastewater Treatment Principles, Modelling and Design. *IWA Publishing*. London, United Kingdom.
- Hidalgo, D., M. Gómez, J. M. Martín-Marroquín, A. Aguado, and E. Sastre. 2015. "Two-Phase Anaerobic Co-Digestion of used Vegetable Oils' Wastes and Pig Manure." *International Journal of Environmental Science and Technology* 12 (5): 1727-1736.
- Hidalgo, D., J. M. Martín-Marroquín, and E. Sastre. 2014. "Single-Phase and Two-Phase Anaerobic Co-Digestion of Residues from the Treatment Process of Waste Vegetable Oil and Pig Manure." *Bioenergy Research* 7 (2): 670-680.
- Hwang, Seokhwan, Yongse Lee, and Keunyoung Yang. 2001. "Maximization of Acetic Acid Production in Partial Acidogenesis of Swine Wastewater." *Biotechnology and Bioengineering* 75 (5): 521-529.
- Jang, H. M., H. U. Cho, S. K. Park, J. H. Ha, and J. M. Park. 2014. "Influence of Thermophilic Aerobic Digestion as a Sludge Pre-Treatment and Solids Retention Time Ofmesophilic Anaerobic Digestion on the Methane Production, Sludge Digestion and Microbial Communities in a Sequential Digestion Process." *Water Research* 48 (1): 1-14.
- Jensen, P. D., H. Ge, and D. J. Batstone. 2011. "Assessing the Role of Biochemical Methane Potential Tests in Determining Anaerobic Degradability Rate and Extent." *Water Science and Technology* 64 (4): 880-886.
- Joshi, P.D. (2014). " Effect of Pre-treatment using Ultrasound and Hydrogen Peroxide on Digestion of Waste Activated Sludge in an Anaerobic Membrane Bioreactor." Masters thesis, University of Waterloo, Canada.

- Kianmehr, P. (2010). "Characterization of Pretreatment Impacts Properties of Waste Activated Sludge and Digestibility." PhD thesis, University of Waterloo, Canada.
- Labatut, R.A., Angenent, L.T., Scott, N.R., 2011. "Biochemical methane potential and biodegradability of complex organic substrates". *Bioresour. Technol.* 102 (3), 2255–2264.
- Lesteur, M., Bellon-Maurel, V., Gonzalez, C., Latrille, E., Roger, J.M., Junqua, G., Steyer, J.P., 2010. "Alternative methods for determining anaerobic biodegradability: a review Process" *Biochem.* 45 (4), 431–440.
- Li -, Y. Y. and T. Noike. 1992. "Upgrading of Anaerobic Digestion of Waste Activated Sludge by Thermal Pretreatment." *Water Science and Technology* 26 (3-4): 857-866.
- Li, C., P. Champagne, and B. C. Anderson. 2014. "Anaerobic Co-Digestion of Municipal Organic Wastes and Pre-Treatment to Enhance Biogas Production from Waste." *Water Science and Technology* 69 (2): 443-450.
- Maspolim, Yogananda, Yan Zhou, Chenghong Guo, Keke Xiao, and Wun Jern Ng. 2015. "Comparison of Single-Stage and Two-Phase Anaerobic Sludge Digestion Systems – Performance and Microbial Community Dynamics." *Chemosphere* 140 (0): 54-62.
- Mata-Alvarez, J., J. Dosta, M. S. Romero-Güiza, X. Fonoll, M. Peces, and S. Astals. 2014. "A Critical Review on Anaerobic Co-Digestion Achievements between 2010 and 2013." *Renewable and Sustainable Energy Reviews* 36 (Complete): 412-427.
- Merlin Christy, P., L. R. Gopinath, and D. Divya. 2014. "A Review on Anaerobic Decomposition and Enhancement of Biogas Production through Enzymes and Microorganisms." *Renewable and Sustainable Energy Reviews* 34: 167-173.
- Min, K. S., A. R. Khan, M. K. Kwon, Y. J. Jung, Z. Yun, and Y. Kiso. 2005. "Acidogenic Fermentation of Blended Food-Waste in Combination with Primary Sludge for the Production of Volatile Fatty Acids." *Journal of Chemical Technology and Biotechnology* 80 (8): 909-915.
- Nges, I. A., & Liu, J. 2009. "Effects of anaerobic pre-treatment on the degradation of dewatered-sewage sludge". *Renewable Energy*, 34(7), 1795-1800.
- Nielsen, H.B., Z. Mladenovska, P. Westermann, B.K. Ahring. 2004. "Comparison of Two-Stage Thermophilic Anaerobic Digestion with One-Stage Thermophilic Digestion of Cattle Manure. ". *Biotechnol. Bioeng.* 86:291–300.
- Parker, W. J. 2014. CIVE 770 Advanced Wastewater Treatment: Theory and Practice. Waterloo, ON: University of Waterloo.

- Parker, W.J. 2005. "Application of the ADM1 model to advanced anaerobic digestion". *Bioresource Technology* 96, 1832-42 (2005).
- Parkin, G. F., & Owen, W. F., 1986. "Fundamentals of anaerobic digestion of wastewater sludges". *Journal of Environmental Engineering*, 112(5), 867-920.
- Pavlostathis, Spyros G. and James M. Gossett. 1986. "Kinetic Model for Anaerobic Digestion of Biological Sludge." *Biotechnology and Bioengineering* 28 (10): 1519-1530.
- Prashanth, S., Kumar, P., Mehrotra, I., 2006. " Anaerobic degradability: effect of particulate COD". *J. Environ. Eng. Sci.* 132 (4), 488–496.
- Pohland F.G. and Ghosh S. 1971. "Development in Anaerobic Stabilization of Organic Wastes. the Two-Phase Concept." *Environ Lett* 1 (4): 255-266.
- Raposo, F., Fernandez-Cegri, V., De la Rubia, M.A., Borja, R., Beline, F., et al., 2011. "Biochemical methane potential (BMP) of solid organic substrates: evaluation of anaerobic biodegradability using data from an international interlaboratory study". *J. Chem. Technol. Biotechnol.* 86 (8), 1088–1098.
- Ramirez, I., Mottet, A., Carrere, H., Deleris, S., Vedrenne, F., and Stayer, J.P. (2009). "Modified ADM1 Disintegration/Hydrolysis Structures for Modeling Batch hermophilic Anaerobic Digestion of hermally Pretreatment Waste Activated ludge." *Water Research*, 43, 3479-3492.
- Rittmann, Bruce E. and Perry L. McCarty. 2012. *Environmental Biotechnology: Principles and Applications* Tata McGraw-Hill Education.
- Shimizu, T., K. Kudo, and Y. Nasu. 1993. "Anaerobic Waste-Activated Sludge Digestion - A Bioconversion Mechanism and Kinetic Model." *Biotechnology and Bioengineering* 41 (11): 1082-1091.
- Skiadas, I. V., Gavala, H. N., Lu, J., & Ahring, B. K., 2005. Thermal pre-treatment of primary and secondary sludge at 70 C prior to anaerobic digestion. *Water Science and Technology*, 52(1-2), 161-166.
- Straub, A. J., Conklin, A. S., Ferguson, J. F., and Stensel, H. D. (2006). " Use of the ADM1 to investigate the effects of acetoclastic methanogen population dynamics on mesophilic digester stability". *Water Science and Technology*, 54(4): 59-66.
- Tchobanoglous, G., F. L. Burton, H. D. Stensel, and Metcalf & Eddy. 2003. *Wastewater Engineering : Treatment and Reuse*. 4th ed. / revised by George Tchobanoglous, Franklin L. Burton, H. David Stensel. ed. Boston: Boston : McGraw-Hill.
- Tattersall, J. M., G. Knight, and B. Ning. 2011. "10 Years of Integrating Thermal Hydrolysis into

Biosolids Treatment – What are the Lessons Learned? " *Proceedings of the WEFTEC Conference*, Los Angeles, California, October

Valo, Alexandre, H el ene Carr ere, and Jean Philippe Delgen es. 2004. "Thermal, Chemical and Thermo-Chemical Pre-Treatment of Waste Activated Sludge for Anaerobic Digestion." *Journal of Chemical Technology & Biotechnology* 79 (11): 1197-1203.

Ventura, Jey-R Sabado, Jehoon Lee, and Deokjin Jahng. 2014. "A Comparative Study on the Alternating Mesophilic and Thermophilic Two-Stage Anaerobic Digestion of Food Waste." *Journal of Environmental Sciences* 26 (6): 1274-1283.

Vandenburgh, S. R., & Ellis, T. G. (2002). Effect of varying solids concentration and organic loading on the performance of temperature phased anaerobic digestion process. *Water environment research*, 142-148.

Wahidunnabi, A. K. and C. Eskicioglu. 2014. "High Pressure Homogenization and Two-Phased Anaerobic Digestion for Enhanced Biogas Conversion from Municipal Waste Sludge." *Water Research* 66: 430-446.

Yasui, H., Goel, R., Li, Y. Y., and Noike, T. (2008). "Modified ADM1 structure for modelling municipal primary sludge hydrolysis". *Water Research*, 42(1-2): 249-259.

Xue, Yonggang, Huajie Liu, Sisi Chen, Norbert Dichtl, Xiaohu Dai, and Ning Li. 2015. "Effects of Thermal Hydrolysis on Organic Matter Solubilization and Anaerobic Digestion of High Solid Sludge." *Chemical Engineering Journal* 264 (Complete): 174-180.

Zamanzadeh M. (2012). " Enhancement of Modeling Phased Anaerobic Digestion Systems through Investigation of Their Microbial Ecology and Biological Activity." PhD Thesis, University of Waterloo, Canada.

Zhang, T. C. and T. Noike. 1991. "Comparison of One-Phase and Two-Phase Anaerobic Digestion Processes in Characteristics of Substrate Degradation and Bacterial Population Levels." *Water Science and Technology* 23 (7-9): 1157-1166.

Appendix A System-1

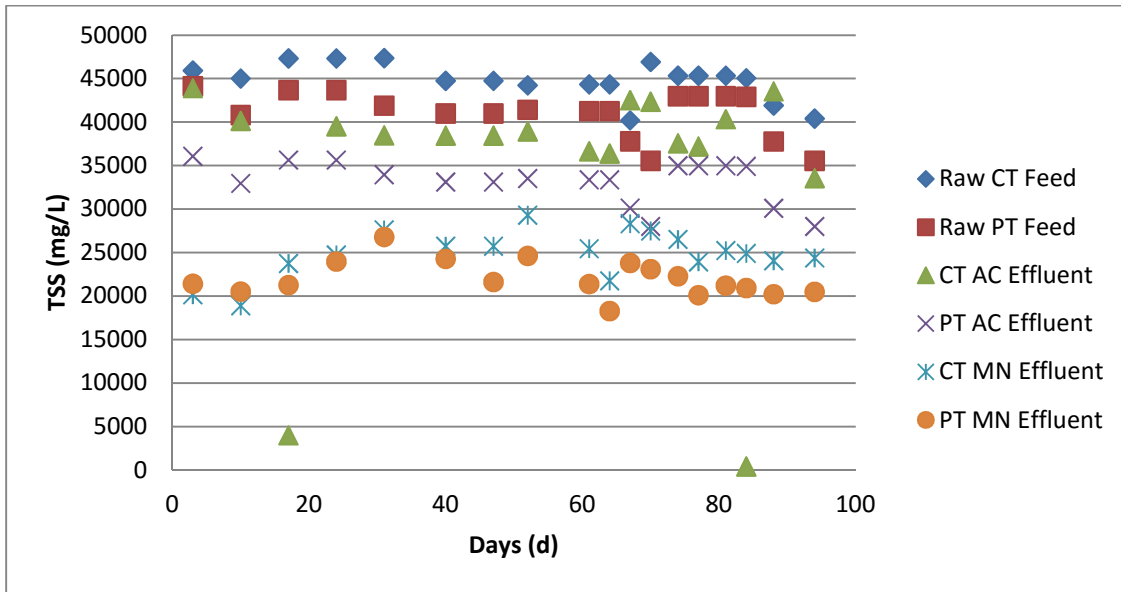

Figure A 1: TSS concentrations in System-1

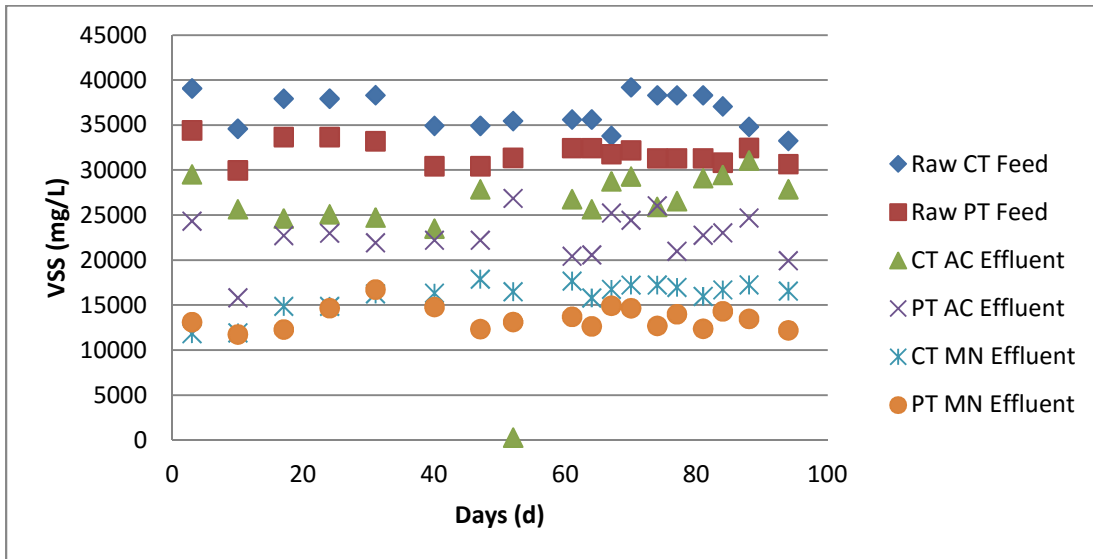

Figure A 2: VSS concentrations in System-1

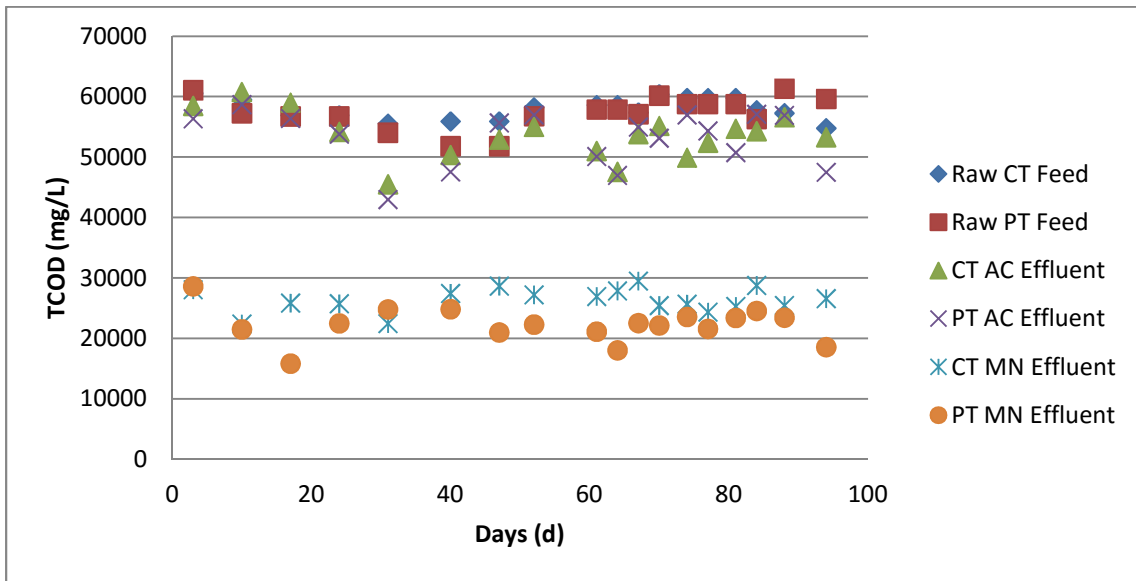

Figure A.3: TCOD concentrations in System-1

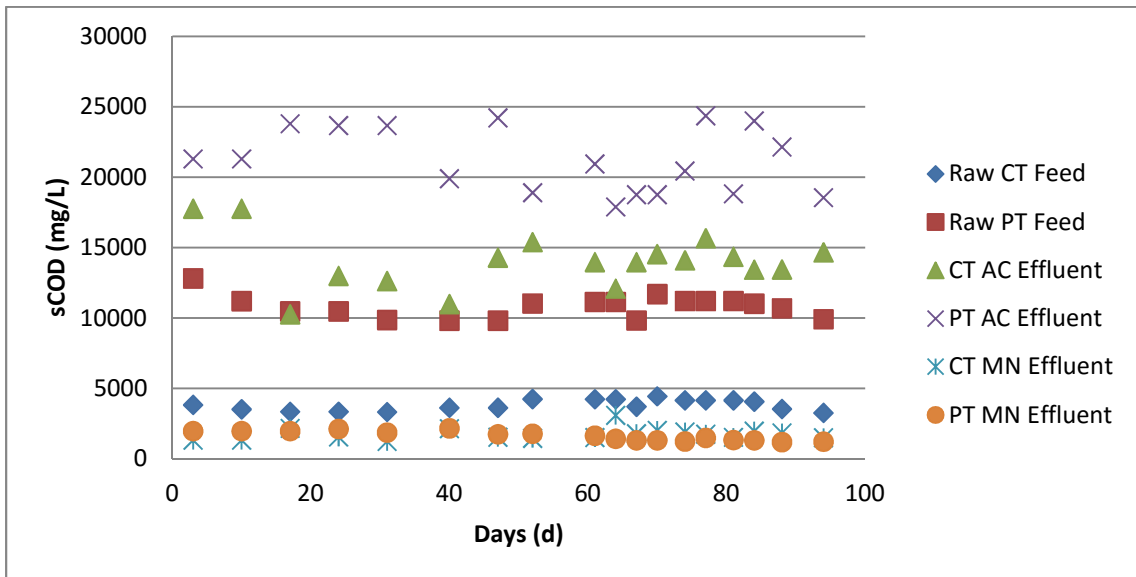

Figure A.4: sCOD concentrations in System-1

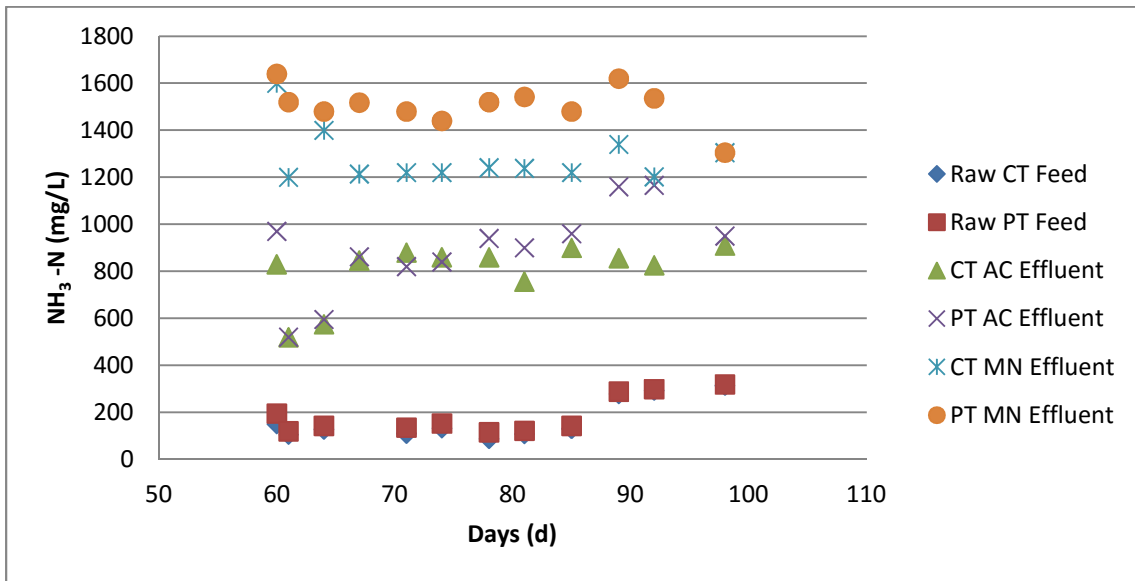

Figure A.5: $\text{NH}_3\text{-N}$ concentrations in System-1

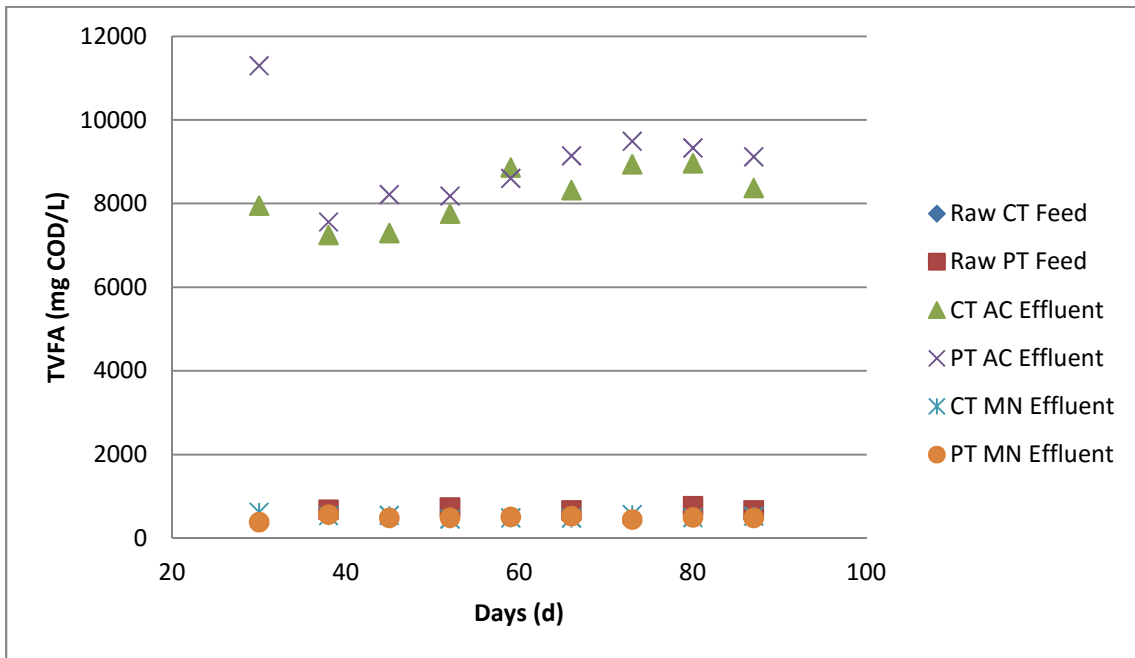

Figure A.6: TVFA concentrations in System-1

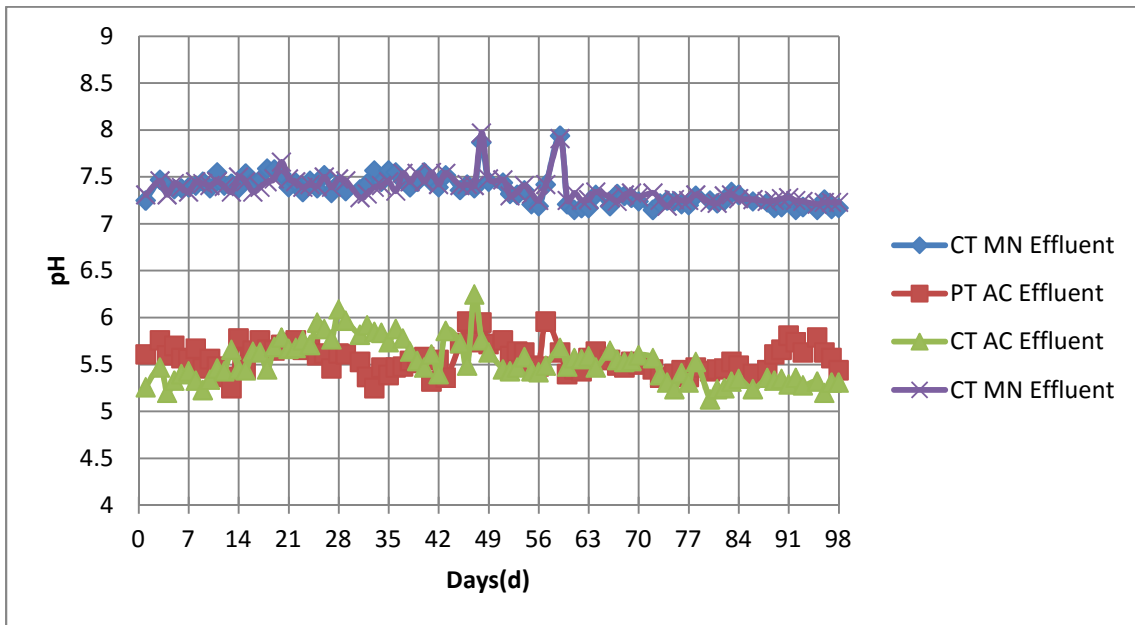

Figure A.7: pH of acidogenic and methanogenic digester effluents in System-1

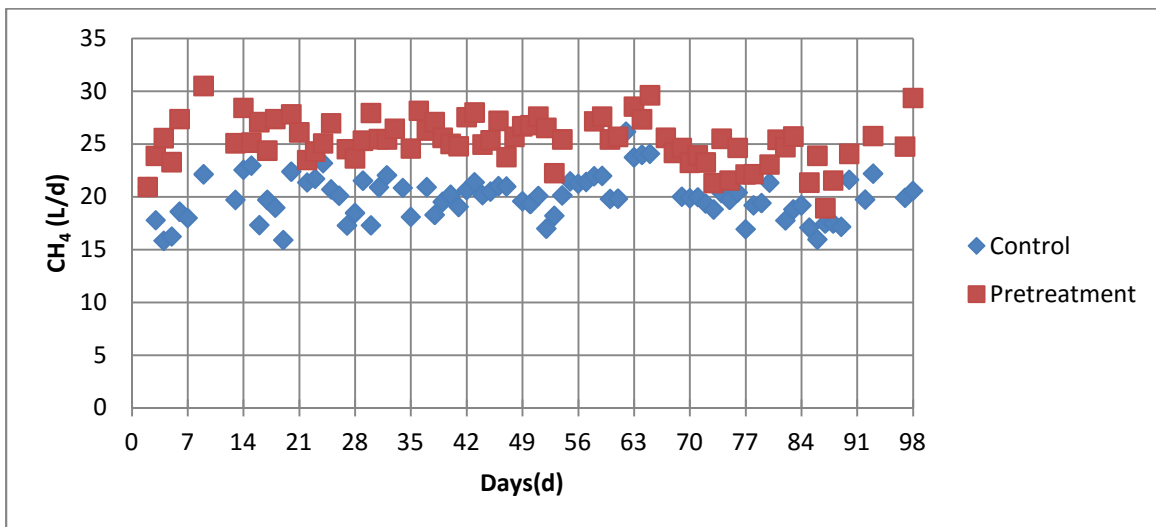

Figure A.8: Daily methane production rate in methanogenic digester in System-1

Appendix B System-2

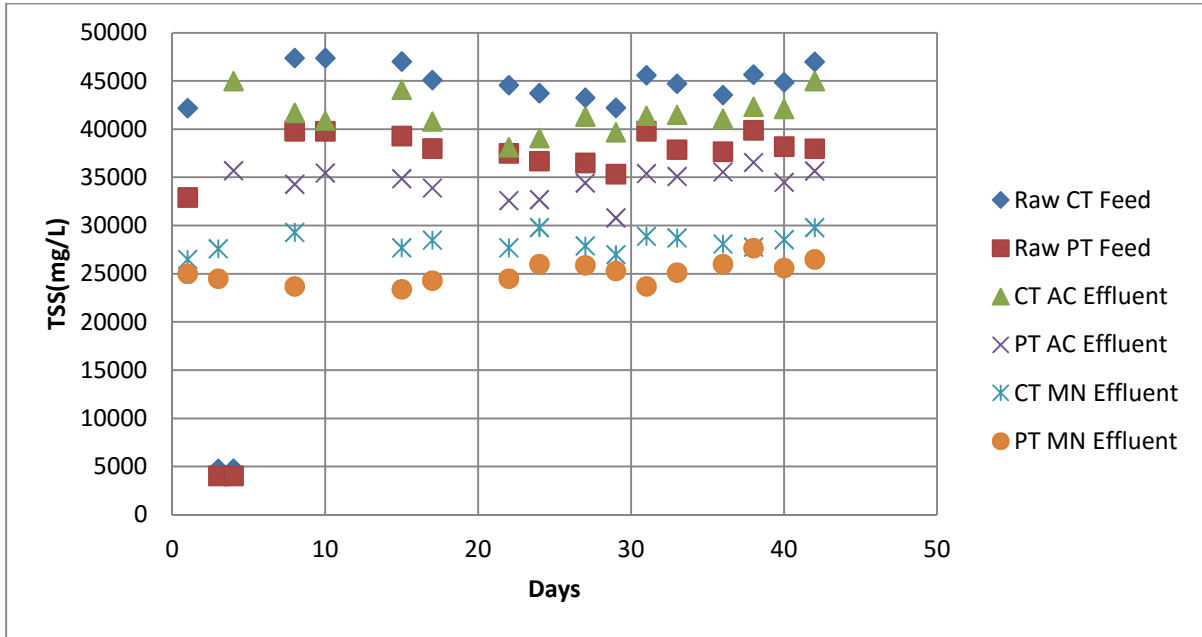

Figure B.1: TSS concentrations in System-2

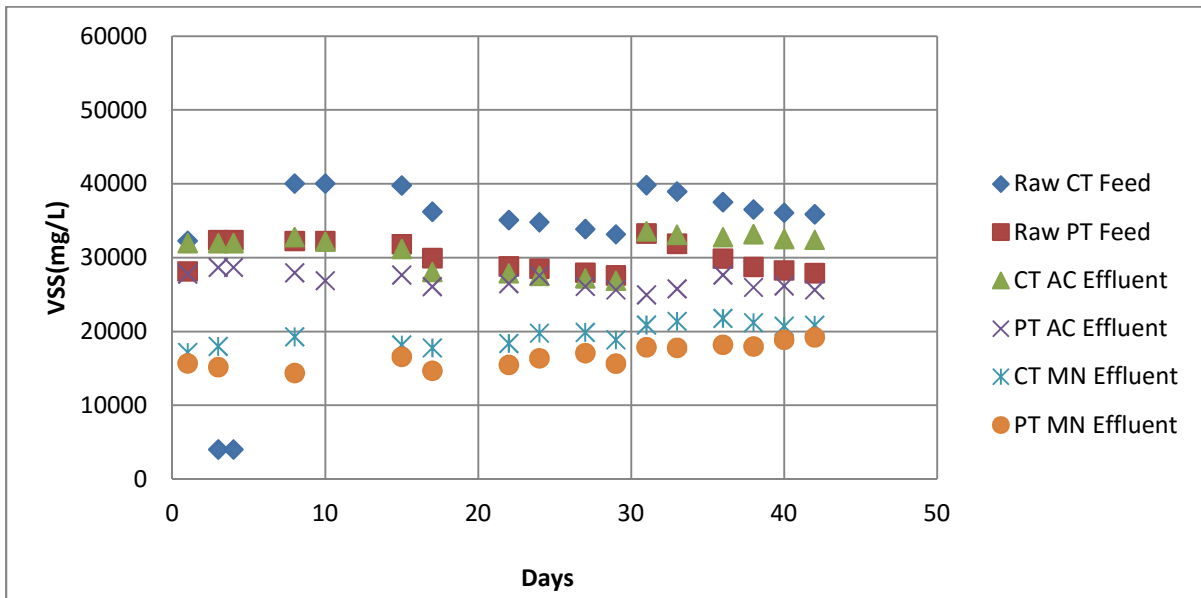

Figure B.2: VSS concentrations in System-2

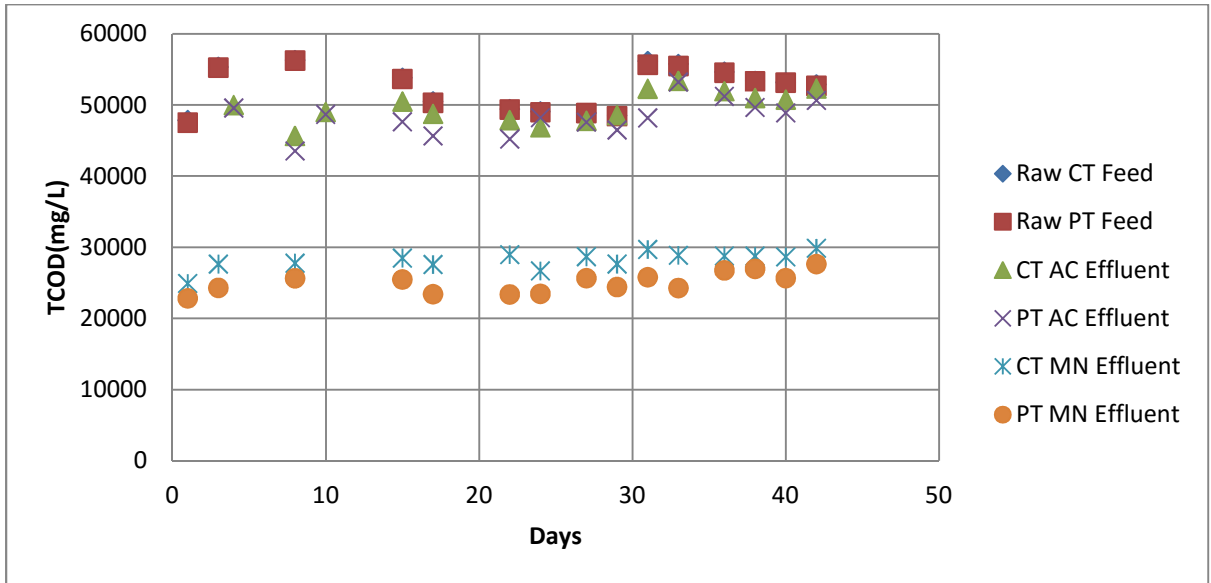

Figure B.3: TCOD concentrations in System-2

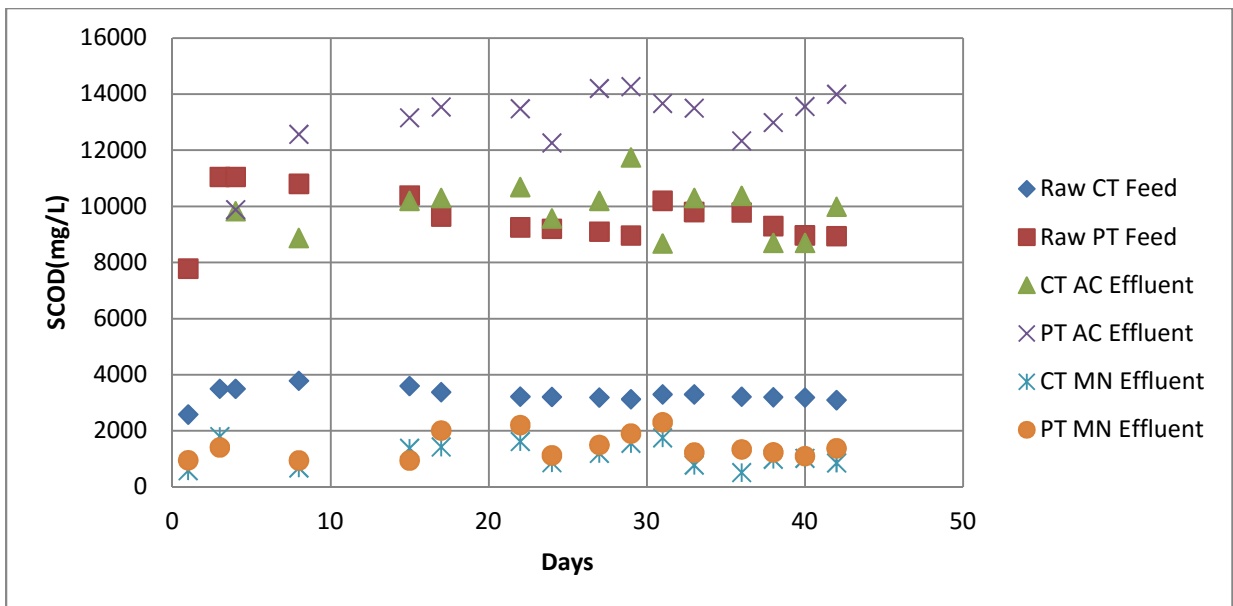

Figure B.4: sCOD concentrations in System-2

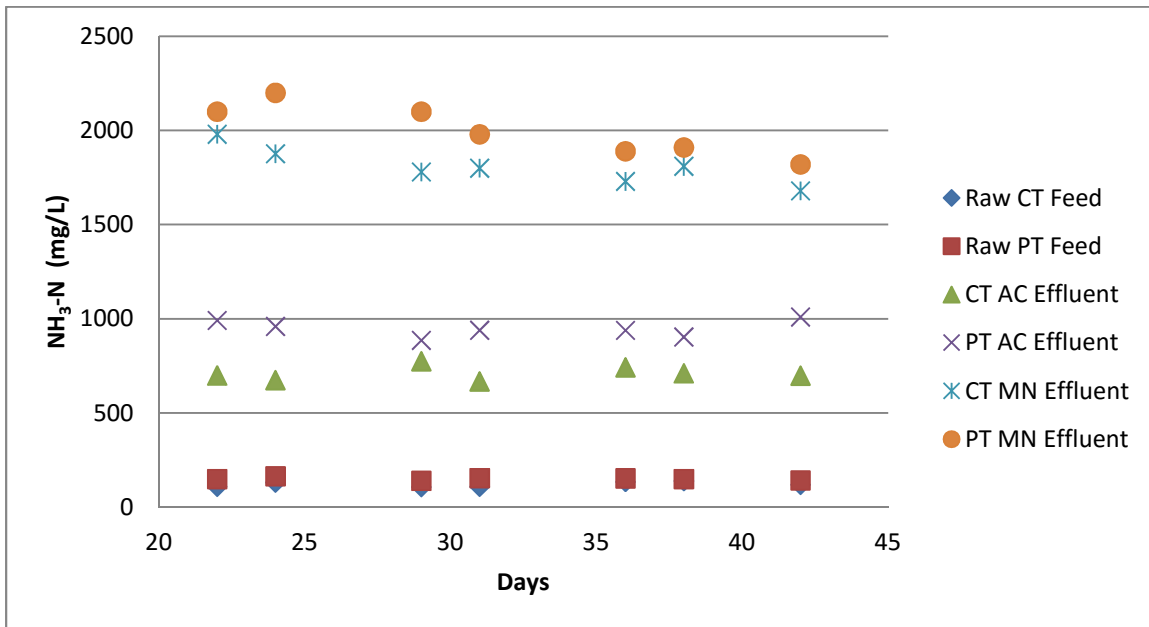

Figure B.5: $\text{NH}_3\text{-N}$ concentrations in System-2

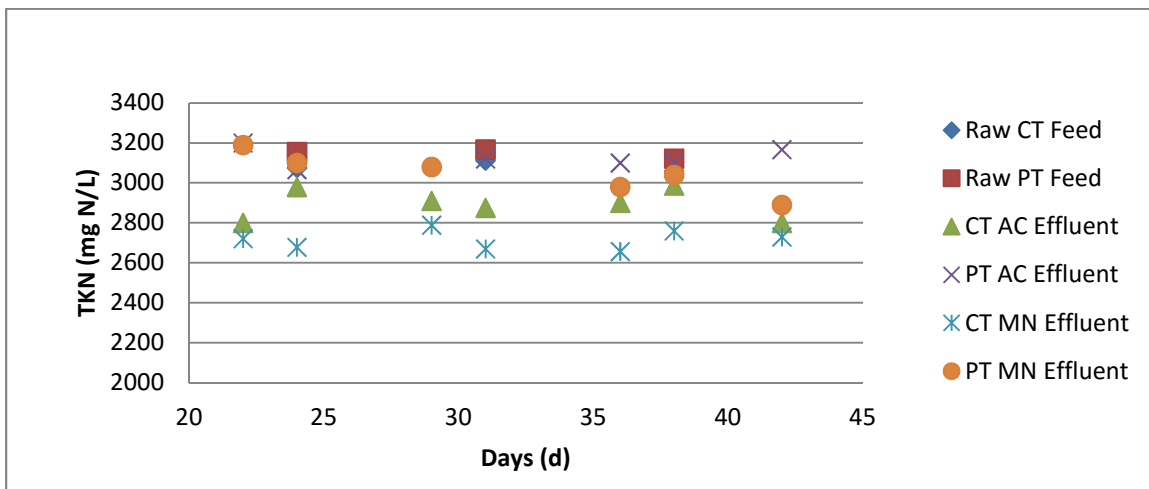

Figure B.6: TKN concentrations in System-2

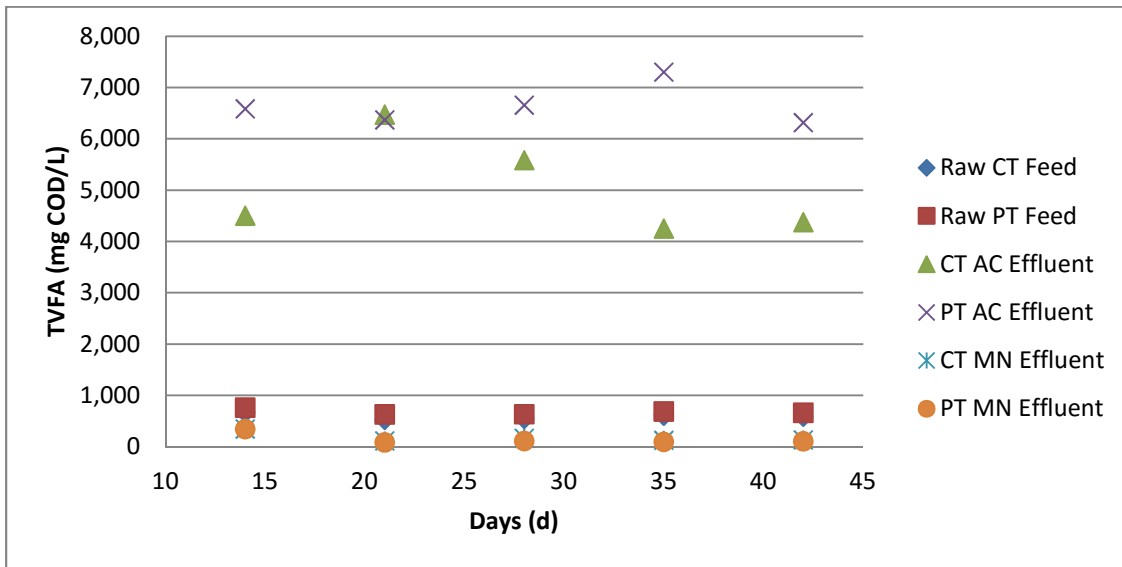

Figure B.6: TVFA concentrations in System-2

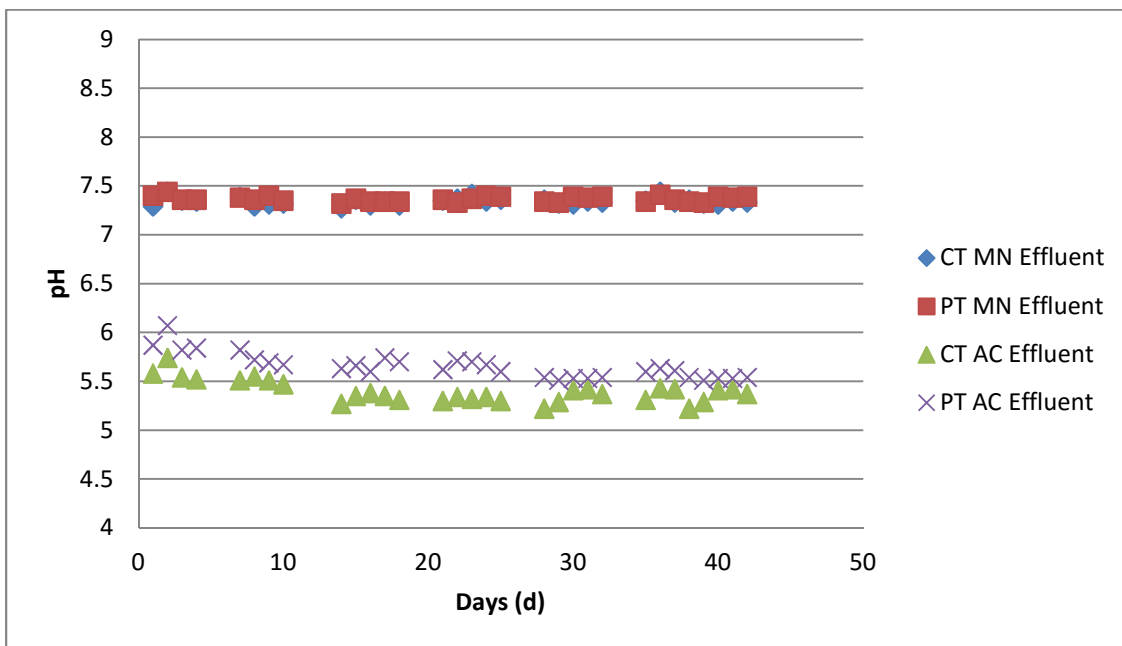

Figure B.7: pH of acidogenic and methanogenic digester effluents in System-2

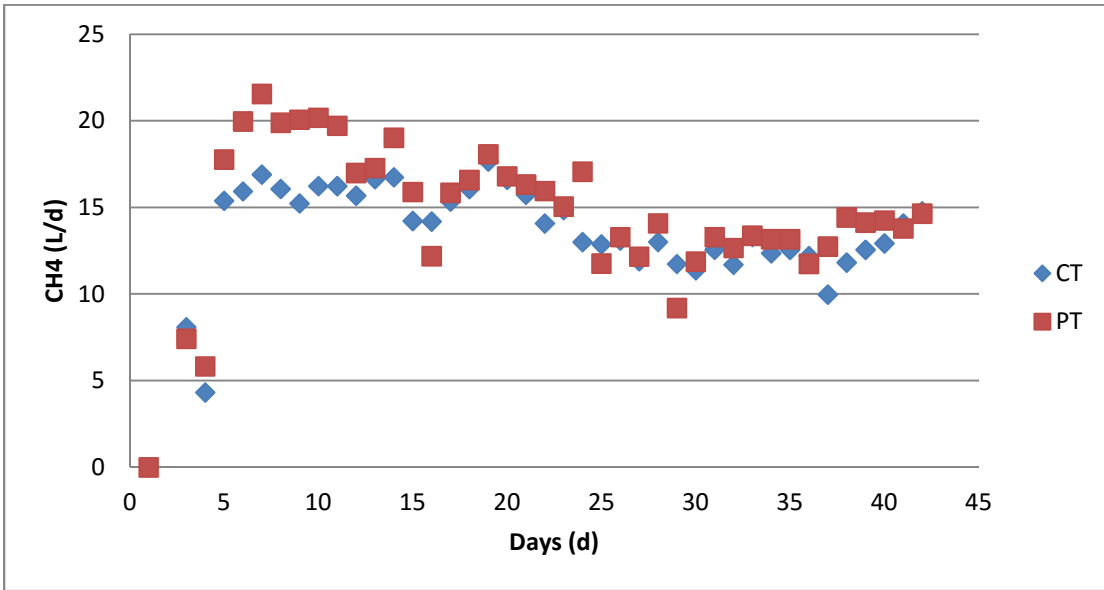

Figure B.8: Daily methane production rate in methanogenic digester in System-2

Appendix C System-3

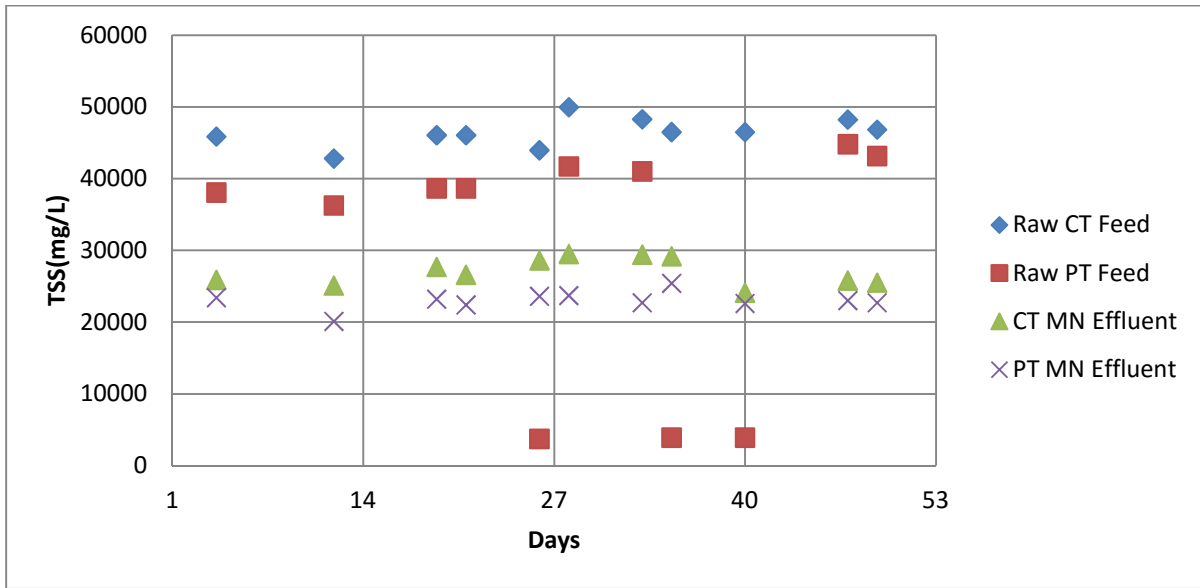

Figure C.1: TSS concentrations in System-3

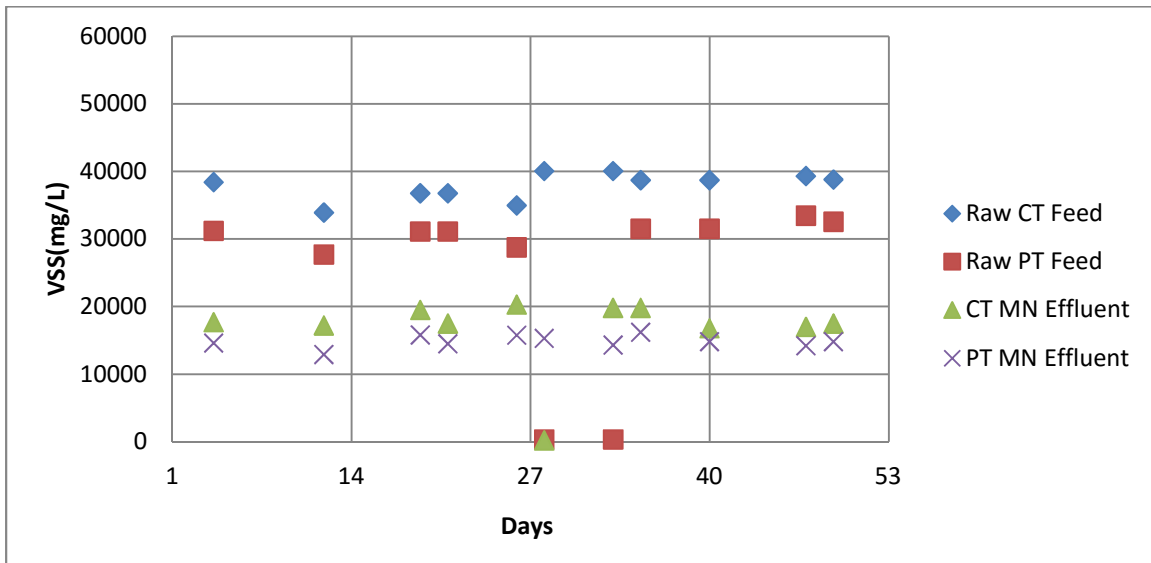

Figure C.2: VSS concentrations in System-3

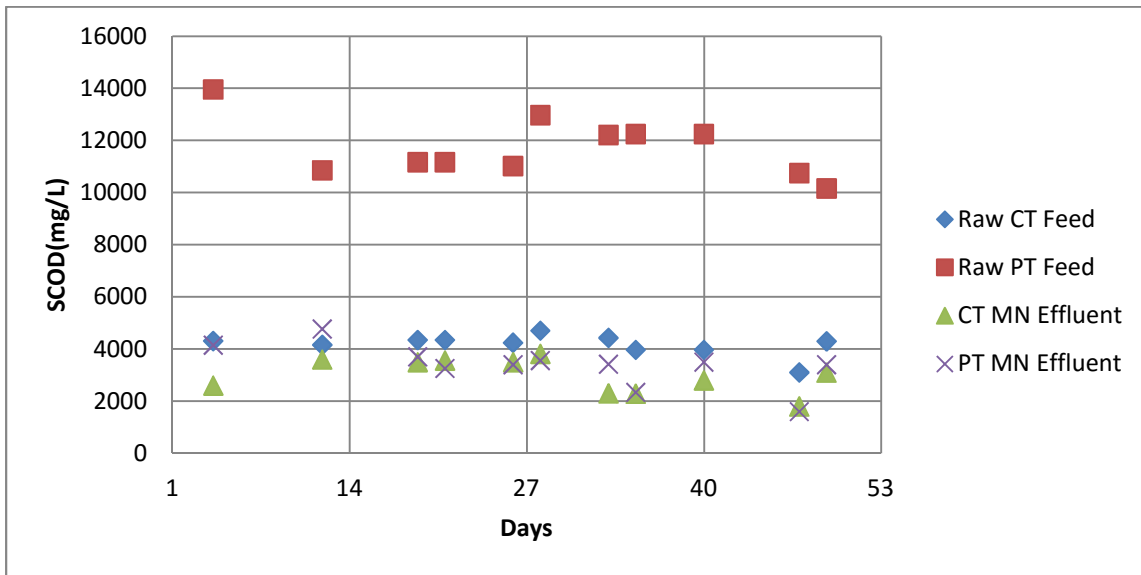

Figure C.3: sCOD concentrations in System-3

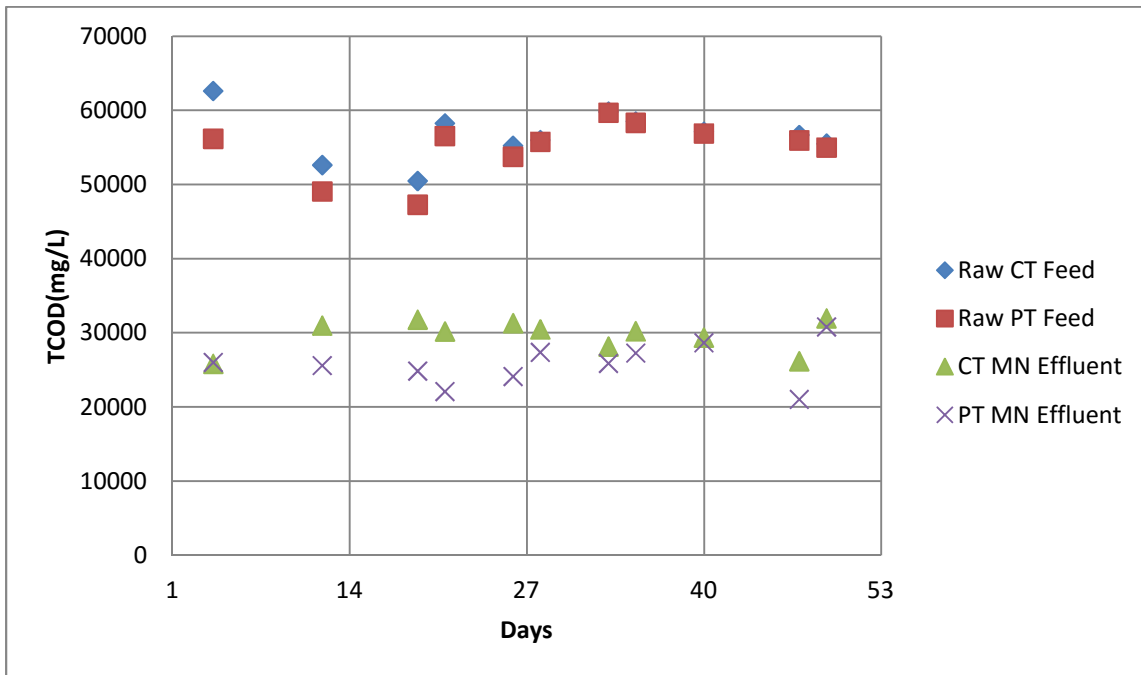

Figure C.4: TCOD concentrations in System-3

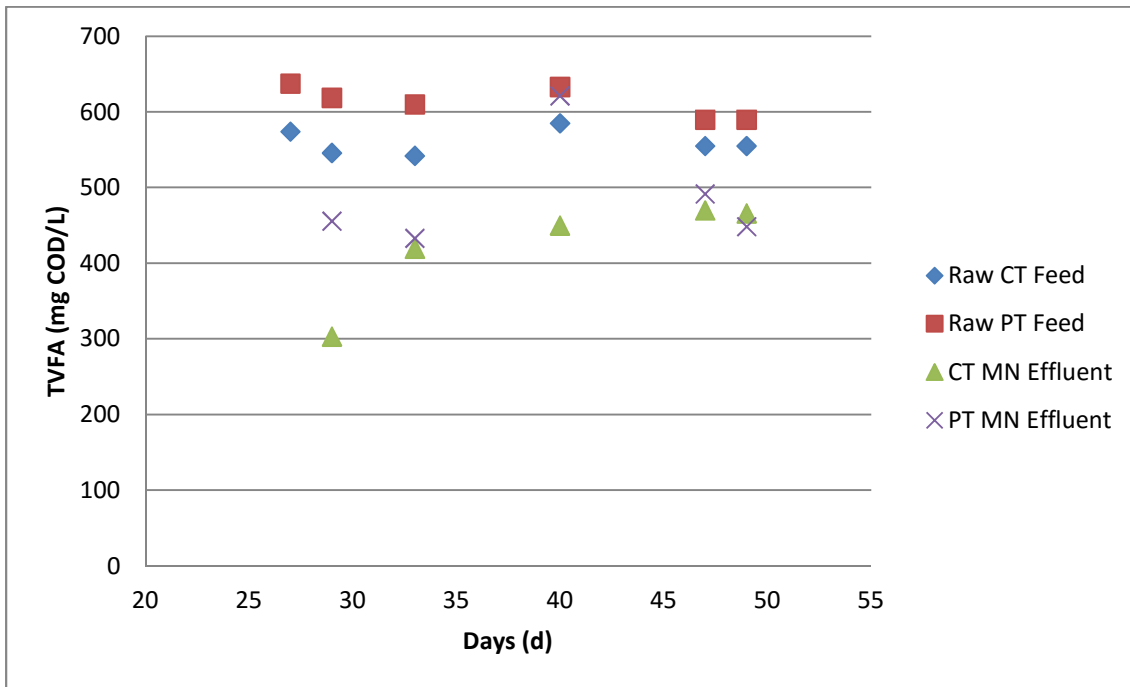

Figure C.5: TVFA concentrations in System-3

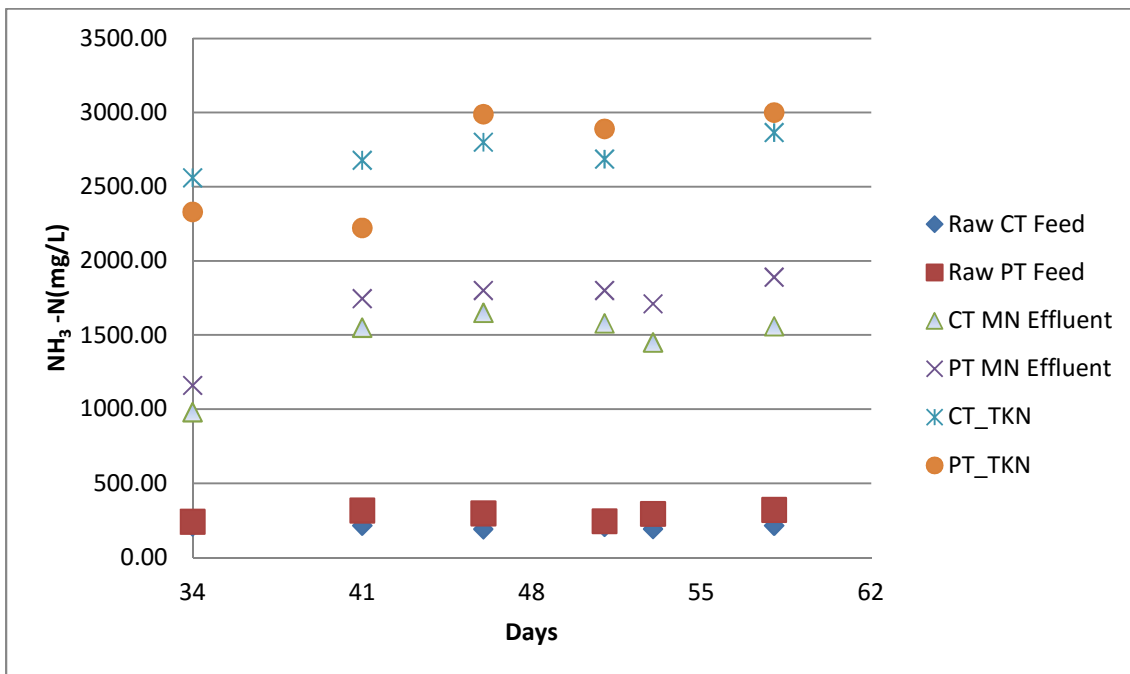

Figure C.6: NH₃-N concentrations in System-3

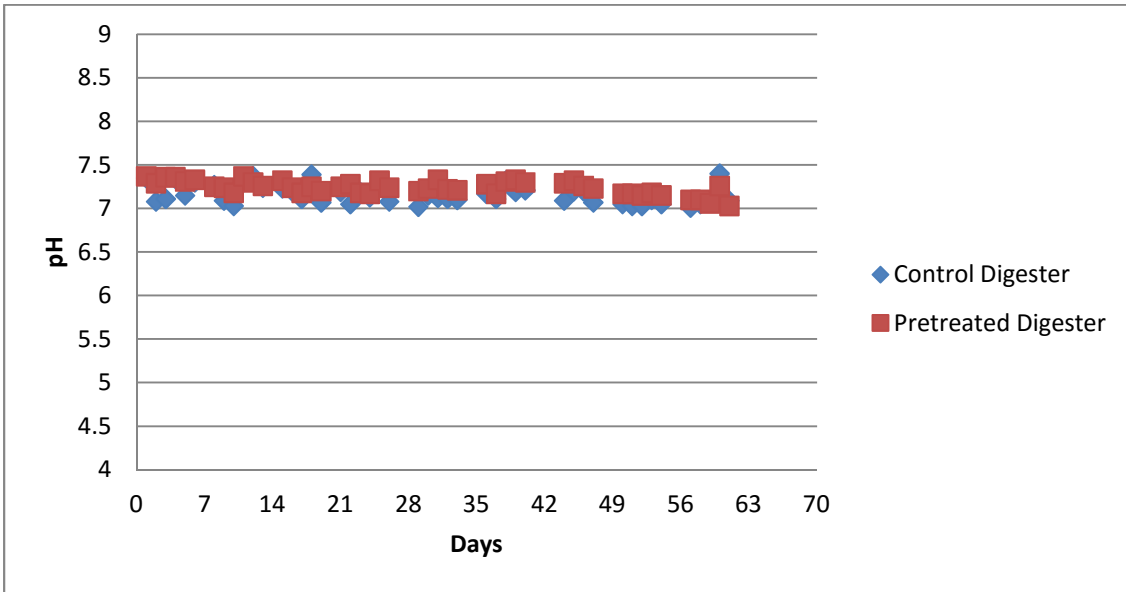

Figure C.7: pH of acidogenic and methanogenic digester effluents in System-3

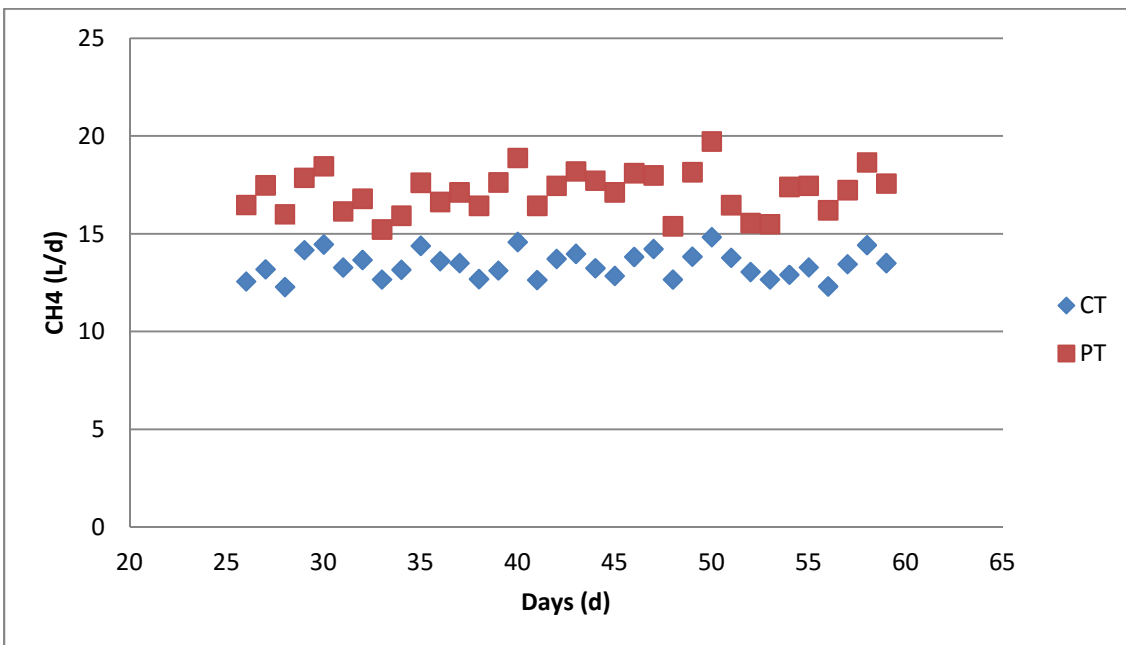

Figure C.8: Daily methane production rate in methanogenic digester in System-3